

# Intelligent Scanner

Professional Lighting Technology

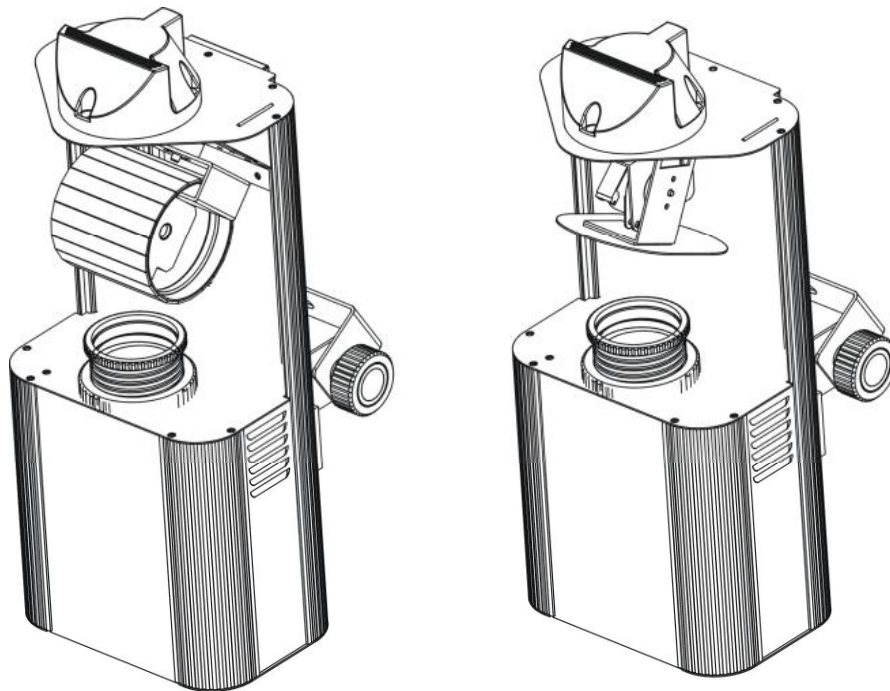

## User Guide

Please read the instructions carefully before use

# **INDEX**

- 1. Safety Introduction**
- 2. Technical Specification**
- 3. How To Control The Unit**
- 4. DMX512 Configuration**
- 5. DMX512 Connection**
- 6. Troubleshooting**
- 7. Fixture Cleaning**

# 1. Safety Introduction



## WARNING

Please read the instructions carefully which include important information about the installation, operation and maintenance.

- ⑤ Please keep this booklet with the unit for future consultation. If you sell the unit to another user, be sure that the new user also receives this instruction booklet thus giving them the necessary information about the use and general warnings regarding the unit.
- ⑤ Before the initial start-up, please unpack and carefully check all components in case any damage may have occurred during shipping.
- ⑤ Locate a suitable spot for your device where there is good ventilation. Also, make sure that no ventilating fans or slots are blocked.
- ⑤ Protect our environment! Please dispose of the packing boxes properly.
- ⑤ The electrical work that is necessary for installation must be done by qualified personnel.
- ⑤ Always remember to unplug the unit from the main power before any service is done. Do not open the unit. There are no serviceable parts inside.
- ⑤ It is very important to ground the yellow/green conductor to earth in order to meet regulations for safety.
- ⑤ Check the surrounding area and make sure there are no flammable liquids, water or metal objects that could enter the fixture. If a foreign object enters the unit, immediately disconnect the main power. Also, place the fixture in a well-ventilated room at about 15 cm from the walls.
- ⑤ Do not touch any wires during operation, as high voltage is hazardous.
- ⑤ In the event of serious operating problems, stop using the unit immediately. Never try to repair the unit yourself. Repairs carried out by unqualified personnel can lead to damage or malfunction. Please contact the nearest authorized Technical Assistance Center. Always use genuine spare parts.

## 2. Technical Specification

### ⑤ Voltage

AC 100V-240V 50-60Hz

### ⑤ LED

Red: 16pcs, Green: 12pcs, Blue: 12pcs, white: 12pcs

### ⑤ Dimension

385×170×122mm(LED-635S)

405×170×122mm(LED-635B)

### ⑤ Weight

2.6KG(LED-635S)

3KG(LED-635B)

- ⑤ The unit is a DMX512 scanner. It features full DMX512 control, 10 gobos/colors plus open and white, focus adjustable accurate optics system and stepper motor with blackout feature. Fan cooled.
- ⑤ It can be operated by DMX512 control or can be used as an individual unit without controller.
- ⑤ It can be linked together as many as required in master/slave mode, and perform the great built-in programmed lighting shows triggered by music.
- ⑤ Please use a 3 pin XLR cable/plug when connecting them together.
- ⑤ It features different pre-programmed chase patterns.

# 3. How To Control The Unit

## (1) Master/Slave operation

The unit can be linked together in daisy chain as many as you need in master/slave mode to perform the great built-in pre-programmed lighting shows triggered by music.

### In Master/Slave mode refer to the DMX settings below:

**Master unit: DMX start address MUST be set to 001. (first DIP switch = ON, all other are OFF)**

**Slave units: DMX start address may have any value but NOT 001 (example: set the first 3 DIP switches to ON)**

\* 2-light show

Dipswitch 10 “off” means the unit works normally and “on” means inversion. In order to create a great light show, you can set dip switch 10 “on” on any unit that is linking to the master unit to get contrast movement to the master unit, even if you have two units only. Dipswitch 10 on the first ( Master ) unit is no use for the 2-light show as it is the master unit that operates the light show.

## (2) By easy controller

The easy remote control is used only in master/slave mode. By connecting to the 1/4” microphone jack of the first unit (its DMX input plug is not used), you will find that the remote control on the first unit will control all the other units for Stand by, Function and Mode.

Built-in lighting shows triggered by Easy Controller:

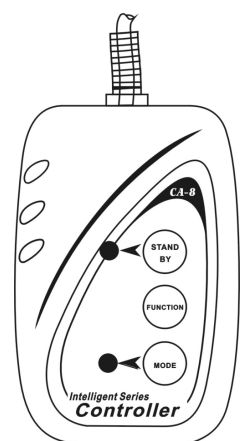

Stand by	Blackout the unit		
Function	1. Sync. Strobe 2. Sound Strobe	Select pattern	Select Chase
Mode	Sound (LED OFF)	Pattern (LED ON)	Chase (LED Slow Strobe)

### (3) Universal DMX controller

When using a universal DMX controller to control the chain of units, you have to set DMX address by Dip switches from 1 to 9 to make sure all the units will receive its DMX signal. Please refer to the following diagram to know how to address your DMX 512 system in the binary code.

#### DMX 512 Address Chart:

Dip-switches	# 1	# 2	# 3	# 4	# 5	# 6	# 7	# 8	# 9	#10
Value	1	2	4	8	16	32	64	128	256	2-light show

· Examples:

Channel 01: dip / on : #1 (=1)







Channel 05: dip / on : #1, #3 (1+4=5)

Channel 09: dip / on : #1,#4 (1+8=9)

Channel 13: dip / on : #1,#3,#4 (1+4+8=13)

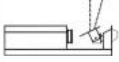
Channel	Dip switches setting
1	<p>ON 1 2 3 4 5 6 7 8 9 10</p>
5	<p>ON 1 2 3 4 5 6 7 8 9 10</p>
9	<p>ON 1 2 3 4 5 6 7 8 9 10</p>
13	<p>ON 1 2 3 4 5 6 7 8 9 10</p>

# 4. DMX512 Configuration

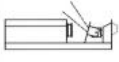
DMX512 Configuration					
Ch1		Ch2		Ch3	Ch4
Pan		Tilt	Barrel Rotation	Pattern/Chase	Strobe
Barrel	Flat	Flat			
			246-255	Stop	250-255 Stand-alone
				Fast	Fast Strobe ////
			135-245	Slow	////
			121-134	Stop	10-249 ///
				Slow	//
			10-120	Fast	/
			0-9	Stop	0-9 No strobe
				250-255 Chase 10	
				240-249 Chase 09	
				230-239 Chase 08	
				220-229 Chase 07	
				210-219 Chase 06	
				200-209 Chase 05	
				190-199 Chase 04	
				180-189 Chase 03	
				170-179 Chase 02	
				160-169 Chase 01	
				150-159 Pattern 15	
				140-149 Pattern 14	
				130-139 Pattern 13	
				120-129 Pattern 12	
				110-119 Pattern 11	
				100-109 Pattern 10	
				090-099 Pattern 09	
				080-089 Pattern 08	
				070-079 Pattern 07	
				060-069 Pattern 06	
				050-059 Pattern 05	
				040-049 Pattern 04	
				030-039 Pattern 03	
				020-029 Pattern 02	
				010-019 Pattern 01	
				000-009 Blackout	

## 5. DMX512 Connection

The DMX512 is widely used in intelligent lighting control, with a maximum of 512 channels.

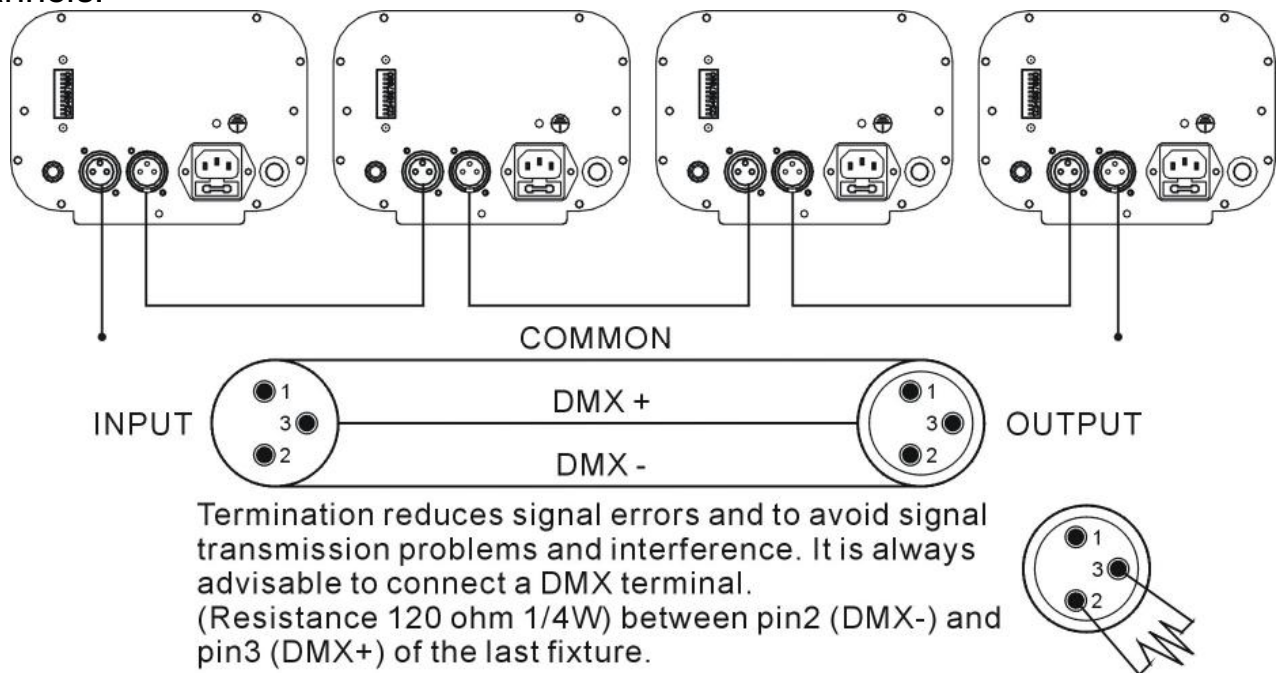

- ⑤ A DMX512 system requires a controller, lighting equipment and cable. These are connected together in a “daisy chain” with the terminator at the end. The cable cannot be branched or split to a “Y” cable.
- ⑤ The terminator requires a 90-120 Ohm 1/4 Watt resistor soldered between two signal cables.
- ⑤ The DMX512 uses a very high-speed signal. Inadequate or damaged cables, bad solder joints or corroded connectors can easily distort the signal and shut down the system. A reliable DMX512 system starts with good quality cables.
- ⑤ Each lighting unit needs to have an address set to receive the data sent by the controller. The address number is between 0-511. The end of the DMX512 system should be terminated reducing signal errors.
- ⑤ 3 pin XLR connectors are more popular than 5 pin XLR.
  - 3 pin XLR: Pin 1: GND, Pin 2: Negative signal (-), Pin 3: Positive signal (+)
  - 5 pin XLR: Pin 1: GND, Pin 2: Negative signal (-), Pin 3: Positive signal (+)



## 6. Troubleshooting

Following are a few common problems that may occur during operation.

Here are some suggestions for easy troubleshooting:

### A. The unit does not work, no light and the fan does not work

1. Check the connect power and main fuse.
2. Measure the mains voltage on the main connector.
3. Check the power on LED.

### B. Not responding to DMX controller

1. DMX LED should be on. If not, check DMX connectors, cables to see if link properly.
2. If the DMX LED is on and no response to the channel, check the address settings and DMX polarity.
3. If you have intermittent DMX signal problems, check the pins on connectors or on PCB of the unit or the previous one.
4. Try to use another DMX controller.
5. Check to see if the DMX cables run near or run alongside to high voltage cables that may cause damage or interference to DMX interface circuit.

### C. Some units don't respond to the easy controller

1. You may have a break in the DMX cabling. Check the LED for the response of the master/ slave mode signal.
2. Wrong DMX address in the unit. Set the proper address.

### D. No response to the sound

1. Make sure the unit is not receiving DMX signal.
2. Check microphone to see if it is good by tapping the microphone.

### E. One of the channels is not working well

1. The stepper motor might be damaged or the cable connected to the PCB is broken.
2. The motor's drive IC on the PCB might be out of condition.

## 7. Fixture Cleaning

The cleaning of internal and external optical lenses and/or mirrors must be carried out periodically to optimize light output. Cleaning frequency depends on the environment in which the fixture operates: damp, smoky or particularly dirty surroundings can cause greater accumulation of dirt on the unit's optics.

- § Clean with a soft cloth using normal glass cleaning products.
- § Always dry the parts carefully.
- § Clean the external optics at least once every 20 days. Clean the internal optics at least every 30/60 days.

### **EC Declaration of Conformity**

We declare that our products (lighting equipments) comply with the following specification and bears CE mark in accordance with the provision of the Electromagnetic Compatibility (EMC) Directive 89/336/EEC.

EN55014-2: 1997 A1: 2001, EN61000-4-2: 1995; EN61000-4-3: 2002;  
EN61000-4-4: 1995; EN61000-4-5: 1995, EN61000-4-6: 1996,  
EN61000-4-11: 1994.

&

### **Harmonized Standard**

EN60598-1: 2000+ALL: 2000+A12: 2002  
Safety of household and similar electrical appliances  
Part 1: General requirements

# Innovation, Quality, Performance