

User Manual

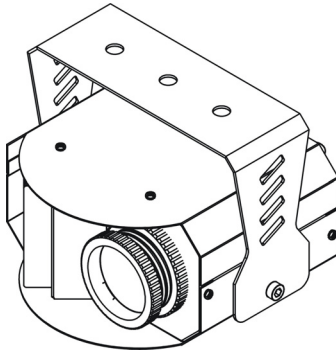

LED-GBF

1. Safety Instruction

- Please keep this User Manual for future consultation. If you sell the unit to another user, be sure that they also receive this instruction booklet.
- Unpack and check carefully there is no transportation damage before using the unit.
- Before operating, ensure that the voltage and frequency of power supply match the power requirements of the unit.
- It's important to ground the yellow/green conductor to earth in order to avoid electric shock.
- The unit must be installed in a location with adequate ventilation, at least 50cm from adjacent surfaces. Be sure that no ventilation slots are blocked.
- Disconnect mains power before replacement or servicing.
- Replace only with the same type.
- Make sure there are not flammable materials close to the unit while operating, as it is fire hazard.

- Use safety cable when fixes this unit.
- In the event of serious operating problem, stop using the unit immediately. Never try to repair the unit by yourself. Repair carried out by unskilled people can lead to damage or malfunction. Please contact the nearest authorized technical assistance center and always use the same type spare parts.
- Do not touch any wire during operation as high voltage might be causing electric shock.

For power supply, do not connect in series much more than 19 units, use another mains supply for next 19 units.

2. Installation

You can install the unit on the truss or ceiling. Use clamps to fix the unit to truss. Always ensure that the unit is firmly fixed to avoid vibration and slipping while operating. Always ensure that the structure to which you are attaching the unit is secure. Also always use a safety cable that can hold 10 times of the weight of the unit when installing the fixture.

3. Technical Specification

Gobo Wheel: 15 gobos + white

Power supply: AC 120V~50Hz 230V~60Hz

Power consumption: 31W

LED: 1 x 10 W Cool White

Dimension : 246 x 192 x162 mm

Weight: 2.8 kg

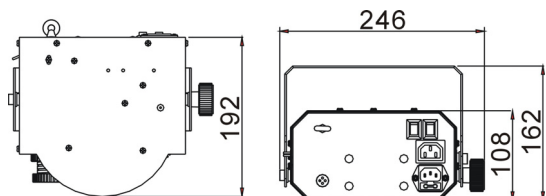

4. Function Instruction

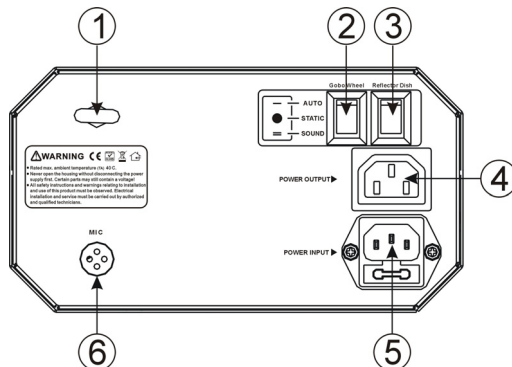

- ① Safety Ring:** Keep the installation safe.
- ② Gobo wheel switch:** Use to set the state of gobo wheel. Set it to **■** mode, gobo wheel will rotate automatically; set it to **●** mode, gobo wheel will stop rotating; set it to **=** mode, gobo wheel will rotate to music.
- ③ Reflector Dish:** Use to set the state of reflector dish. Set it to **■** mode, reflector dish will rotate automatically; set it to **●** mode, reflector dish will stop rotating; set it to **=** mode, reflector dish will rotate to music.
- ④ Mains output:** Connect to supply mains power for the next unit.
- ⑤ Mains input:** Connect to supply mains power.
- ⑥ Microphone:** Receive music for the sound active.