



WT-LGP

Logo Projector is a powerful tool creating a long lasting visual effect. It comes with 7 D size gobos and an interchangeable slot for custom made gobos. With speed and direction adjustable function, the Logo projector is perfect for discos, restaurants, department stores, etc.

- Adjustable gobo rotation direction and speed.
- With an optional CA-5 easy controller for the on/off control.
- Focus adjustable and fan cooled.
- Voltage: AC 120V~60Hz 230V/240V/250V~50Hz/60Hz
- Fuse: 20mm glass 250V T6.3A / 20mm glass 250V T5A
- Bulb: EHJ 24V 250W

Change lamp

- Always switch off the mains supply and never handle the lamp or luminaire when it is hot.
- Do not touch the bulb with bare hands. If this does happen, clean the lamp with denatured alcohol and wipe with a lint free cloth before installing.

Pull the socket off the lamp.

Do not pull the wires.

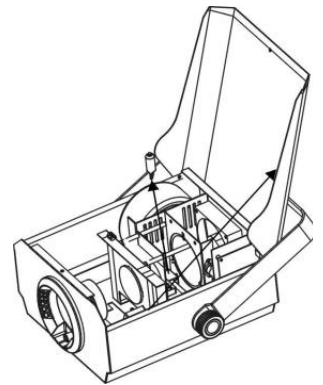

Inserting/Exchanging rotating gobos

Gobo list:

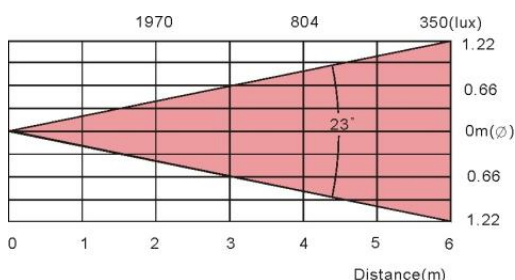
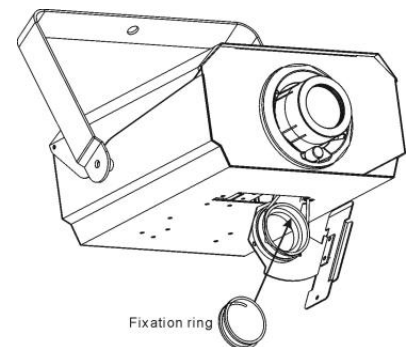

Replacement Lamp Options:

Order Code	Avg Life (Hours)	Manufacturer
BX-AB-ELC	50	XenPow
BO-HLX-64653	50	Osram
BP-13163	35	Philips
BP-13163/5H	500	Philips
BP-13163/10H	1000	Philips

Dimensions/Weight:

Length	Width	Height	Weight
306mm	263mm	140mm	7.2kg

The Projector is best to be placed 5 meters from wall, and from this distance the light effect will cover an area of 2.1 m x 2.1 m.