

C411^{III} L 3.2.3 Using the MPA V L

Using the MPA V L

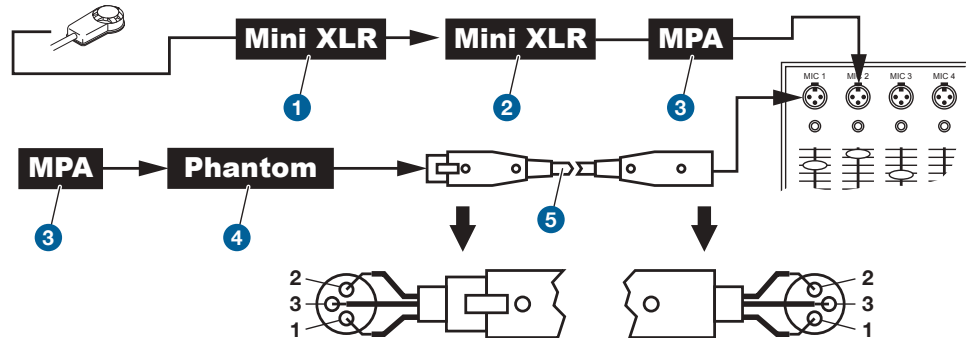

Figure 4: Connection diagram with MPA V L.

- 1) **Connecting the cable:**
Push the mini XLR connector (1) on the pickup cable into the mini XLR socket (2) on the cable of the MPA V L (3) to the stop.
The connector will lock automatically.
Disconnecting the cable: refer to section 3.2.1.
- 2) Connect the MPA V L (3) to a balanced XLR microphone input with phantom power.
- 3) Switch the phantom power on. (Refer to the instruction manual of the unit to which you connected your pickup.)
- 4) **If your mixer provides no phantom power:** Connect the MPA V L (3) to an optional AKG phantom power supply (4) and use an XLR cable (5) to connect the phantom power supply (4) to the desired balanced input.

Connecting to a Bodypack Transmitter 3.2.4 Connecting to a Bodypack Transmitter

Refer to the manual of your bodypack transmitter.