

ALLEN & HEATH

QU-16

- 16 MONO INPUTS
- 3 STEREO INPUTS
- 4 STEREO FX RETURNS
- 16 BUSES
- 12 MIX OUTPUTS
- AES DIGITAL OUT
- USB AUDIO STREAMING
- DAW MIDI CONTROL
- 4 MUTE GROUPS
- 4 FX ENGINES
- 19" RACK MOUNTABLE



RACKMOUNTABLE DIGITAL MIXER

User Guide



For Firmware Version V1.0

Check www.allen-heath for the latest version available

Publication AP9031

Limited One Year Manufacturer's Warranty

This product is warranted to be free from defects in materials or workmanship for period of one year from the date of purchase by the original owner.

To ensure a high level of performance and reliability for which this equipment has been designed and manufactured, read this User Guide before operating.

In the event of a failure, notify and return the defective unit to the place of purchase. If this is not possible then please contact the authorised ALLEN & HEATH distributor or agent in your country as soon as possible for repair under warranty subject to the following conditions:

Conditions Of Warranty

The equipment has been installed and operated in accordance with the instructions in this User Guide.

The equipment has not been subject to misuse either intended or accidental, neglect, or alteration other than as described in the User Guide or Service Manual, or approved by ALLEN & HEATH.

Any necessary adjustment, alteration or repair has been carried out by an authorised ALLEN & HEATH distributor or agent.

This warranty does not cover fader wear and tear.

The defective unit is to be returned carriage prepaid to the place of purchase, an authorised ALLEN & HEATH distributor or agent with proof of purchase. Please discuss this with the distributor or the agent before shipping.

If the unit is to be repaired in a different country to that of its purchase the repair may take longer than normal, whilst the warranty is confirmed and parts are sourced.

Units returned should be packed to avoid transit damage.

In certain territories the terms may vary. Check with your ALLEN & HEATH distributor or agent for any additional warranty which may apply.

If further assistance is required please contact Allen & Heath Ltd.



The Qu range of products complies with the European Electromagnetic Compatibility directives 2004/108/EC and the European Low Voltage directives 2006/95/EC.

Any changes or modifications to the equipment not approved by Allen & Heath could void the compliance of the product and therefore the users authority to operate it.

Qu-16 User Guide AP9031 Issue 1b

Copyright © 2013 Allen & Heath. All rights reserved

ALLEN & HEATH

Allen & Heath Limited, Kernick Industrial Estate, Penryn, Cornwall, TR10 9LU, UK

<http://www.allen-heath.com>

IMPORTANT - Read these instructions before starting:

Safety instructions

Before starting, read the [Important Safety Instructions](#) printed on the sheets supplied with the equipment. For your own safety and that of the operator, technical crew and performers, follow all instructions and heed all warnings printed on the sheet and on the equipment panels.

System operating firmware

The function of the Qu mixer is determined by the firmware (operating software) that runs it. Firmware is updated regularly as new features are added and improvements made. This guide relates to [Version 1.0](#) firmware.

The latest firmware can be downloaded from the Allen & Heath web site, transferred to USB key and then loaded into the Qu mixer using the Firmware Update utility.

- **Check the Allen & Heath web site for the latest version of Qu firmware.**

Software licence agreement

By using this Allen & Heath product and the software within it you agree to be bound by the terms of the relevant [End User Licence Agreement](#) (EULA), a copy of which can be found on the Allen & Heath website in the product's pages. You agree to be bound by the terms of the EULA by installing, copying, or using the software.

Further information

For further information, knowledgebase and technical support please refer to the [Allen & Heath web site](#).

General precautions

- To prevent damage to the controls and cosmetics, avoid placing heavy objects on the control surface, obstructing movement of the motorised faders, scratching the surface or touch screen with sharp objects, or rough handling and vibration.
- Protect the equipment from damage through liquid or dust contamination. Avoid dust or small objects getting into the fader slots. Cover the mixer when it is not being used for a long period.
- Computer and touch screen technology can be affected by extreme cold. If the equipment has been stored in sub-zero temperatures allow time for it to reach normal operating temperature before use at the venue. Recommended operating temperature for Qu is 5 to 35 degrees Celsius.
- Avoid using the equipment in extreme heat and direct sunlight. Make sure the mixer ventilation slots are not obstructed and that there is adequate air movement around the equipment.
- Transport the Qu using a touring grade, purpose designed flightcase with adequate foam lining and internal support for protection.
- Clean the control surface with a soft brush and dry lint-free cloth. Do not use chemicals, abrasives or solvents.
- It is recommended that servicing is carried out only by an authorised Allen & Heath agent. Contact details for your local distributor can be found on the Allen & Heath web site. Allen & Heath do not accept liability for damage caused by maintenance, repair or modification by unauthorised personnel.

1. Packed contents

Qu-16 Mixer



Mains lead • Check this is correct for your territory



User Guide AP9031

Registration Card on rear cover

- Return the card or register online at www.allen-heath.com



Safety Sheets

AP3345 – English
AP7287 – French
AP8513 – Chinese

- Read this before starting

Accessories available

19" Rack Ear Kit Qu-16-RK19

To mount the Qu-16 in a standard 19" rack or flightcase. These fit over the plastic trims.



LEDlamp

Part LEDlampX

Right angled 4-pin XLR with built-in dimmer



Please Note

This User Guide refers to first release Qu-16 firmware version **V1.0**. Several features are not supported by this release. Please refer to the Allen & Heath web site for the latest version of firmware and this user guide. For more details read the Release Notes available with the firmware.

Features not supported by firmware V1.0:

- USB key Scene and mixer data transfer
- User libraries for FX and processing
- Scene Recall Filters and Safes
- User assignable Custom layer
- Qu-Pad wireless remote app for iPad
- dSNAKE port for remote audio connection
- ME personal mixer compatibility
- User permissions

Note – USB streaming is compatible with a MAC computer only. Windows PC is not supported.

2. Contents

1.	Packed contents	4
2.	Contents.....	5
3.	Introduction.....	6
4.	Connection Overview.....	7
4.1	Input Connections.....	7
4.2	Output Connections.....	8
4.3	Other Connections.....	8
4.4	Powering up the mixer	9
5.	Operational Overview	10
5.1	Fader Strips.....	10
5.2	Channel Processing.....	12
5.3	Working with the Processing:	12
5.4	Channel Routing	16
5.5	Working with the Routing screens:.....	16
5.6	Mute Groups	18
5.7	Using the Mute Groups.....	18
5.8	The Master Strip.....	19
5.9	Working with the sends on faders:	20
5.10	Copy, Paste, Reset keys.....	20
6.	Touch Screen Mixing Functions	21
6.1	The Sel screens – Processing and Routing	22
6.2	Home Screen	22
6.3	Home Screen – Changing User.....	22
6.4	Home Screen – Meters	23
6.5	Home Screen – RTA	23
6.6	Home Screen – USB Audio	23
6.7	The FX.....	26
6.8	Working with FX – Adding vocal reverb:	28
6.9	Scene Memories	29
7.	Touch Screen Setup Functions	30
7.1	Audio Setup -PAFL.....	30
7.2	Audio Setup - Talkback	30
7.3	Audio Setup –Signal Generator.....	31
7.4	Audio Setup – Output Patch	31
7.5	Audio Setup - Global.....	31
7.6	Control Setup - SoftKeys	32
7.7	USB Data.....	32
7.8	Network Setup	32
7.9	Utility - Calibration.....	32
7.10	Utility – Qu-Drive	33
7.11	Utility – Firmware Update.....	33
8.	Resetting the Mixer	34
8.1	Reset Mix Settings – A starting point for mixing.....	34
8.2	System Hard Reset	35
9.	Specifications.....	36
9.1	System Block Diagram	37
9.2	Mechanical Details.....	38

3. Introduction



The Qu-16 is a compact, rack mountable digital audio mixer from Allen & Heath. Building on the heritage of the GLD and flagship iLive digital consoles the Qu presents exceptional performance together with an intuitive analogue style user interface with knobs and touch screen, total recall of its settings, full input, output and FX processing, USB multitrack recording capability and remote wireless control using an iPad.

- 16 mono Mic / Line channels with XLR and TRS jack inputs
- 3 stereo Line channels
- 4 built-in FX engines with dedicated stereo FX return channels
- Talkback mic input
- Provides up to 24 simultaneous sources to the mix
- 16 mix buses – 10 mix, 2 FX, LR, PAFL
- 12 XLR mix outputs – 4 mono mix + 3 stereo mix + LR
- 2 channel AES digital output patchable from any mix
- Stereo Alt Out TRS jack output patchable from any mix
- 2TRK output for recording
- Input channel linking
- Input processing – Preamp, HPF, Gate, PEQ, Compressor, Delay
- Mono mix and LR processing – Graphic EQ, Compressor, Delay
- Stereo mix processing – PEQ, Compressor, Delay
- 800x480 colour touch screen for quick control
- Motorised faders for sends on faders and mix recall
- Master strip for quick access to mix levels and processing
- AnaLOGIQ™ recallable analogue preamp
- Effects ported from the flagship iLive console
- 4 assignable SoftKeys
- Quick copy and reset of settings and scenes
- 100 Scene memories
- Qu-Drive for stereo and 18-track recording/playback to USB drive
- USB streaming to/from a MAC computer (PC currently not supported)
- USB key transfer of Scenes and mixer setup (Not supported by V1.0)
- User assignable Custom layer (Not supported by V1.0)
- Qu-Pad wireless remote app for iPad (Not supported by V1.0)
- dSNAKE port for remote audio connection (Not supported by V1.0)
- Compatible with ME personal mixing system (Not supported by V1.0)
- User permissions to restrict operator access (Not supported by V1.0)

4. Connection Overview

The following connections are available on the rear panel of the Qu-16.

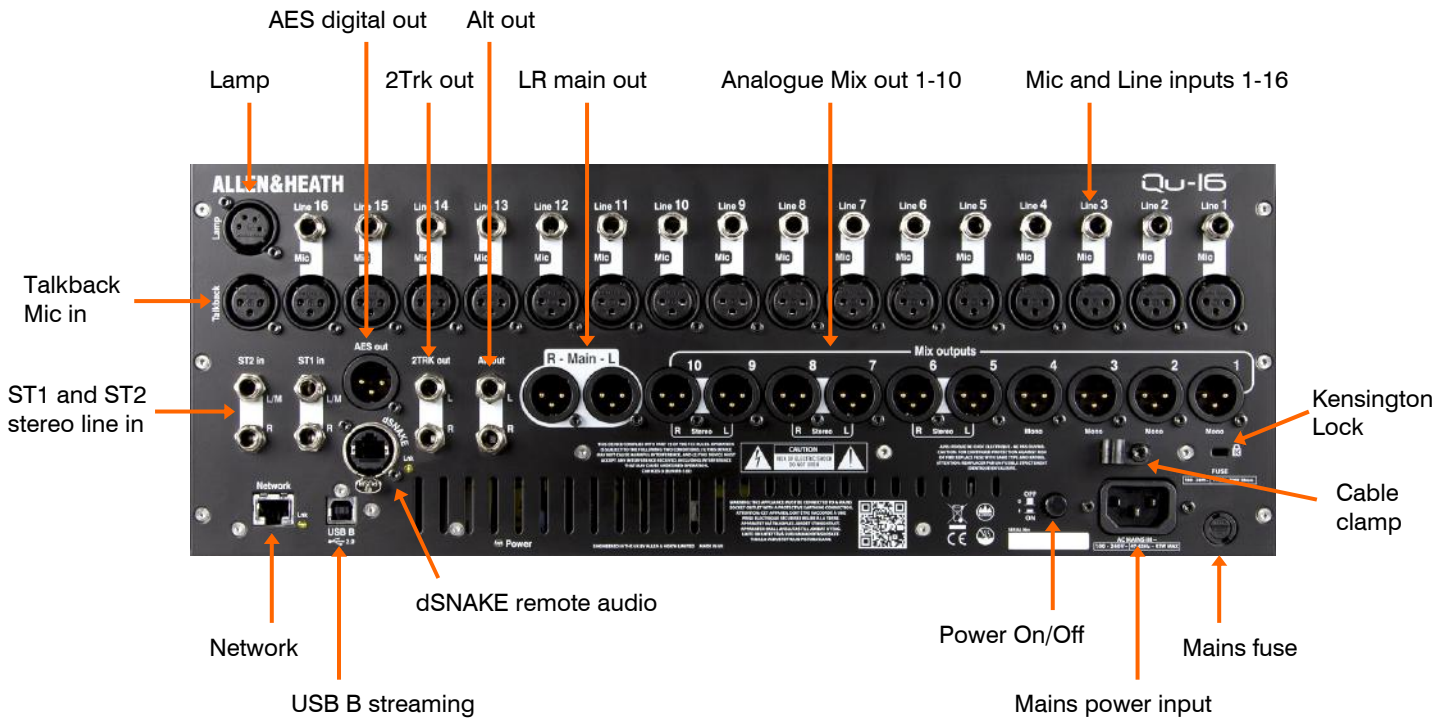

4.1 Input Connections



Mono Line Input – Balanced 1/4" TRS (Tip, Ring, Sleeve) jack input for plugging in line level signals such as multitrack players and radio mic receivers. To work with unbalanced sources use a mono jack or link ring to sleeve within the TRS stereo jack.

Use DI boxes plugged into the Mic input for high impedance, low level sources such as acoustic instrument pickups.



Microphone Input – Balanced XLR input for plugging in a low level source such as a microphone or DI box. 48V can be switched to the socket for condenser mics and active DI boxes that require phantom power.

Note - To avoid loud thumps mute the channel before plugging in cables or switching 48V on or off.

Stereo Line Input – ST1 and ST2 balanced 1/4" TRS (Tip, Ring, Sleeve) jack inputs for plugging in line level stereo sources such as CD players. The L input normals (switches) through the R input so that you can work with a mono source by plugging into just the L/M input.

To work with RCA phono connections use jack to RCA converter plugs.



Talkback Input – Dedicated balanced XLR input for plugging in a microphone to route to the mixes for the engineer to talk to the performers on stage. Phantom power can be switched to the socket for condenser microphones.

4.2 Output Connections



Mix Outputs – Balanced XLR line level outputs for the mono and stereo mixes, for example to feed monitor amplifiers, fill speaker systems, and external processing devices. These use low impedance, high quality differential driver circuits for connection to +4 or 0dBu equipment. Maximum output is +22dBu.

Professional equipment provides ‘balanced’ connections for maximum interference rejection over long cable runs. If you are connecting to ‘unbalanced’ equipment then make sure the XLR pin 3 (signal cold) is linked to pin 1 (signal ground).



Main LR Output – Balanced XLR line level outputs for the main Left and Right stereo mix. These typically plug into the FOH speaker processor, amplifier or powered speakers.



AES Output – 2-channel digital output using a single XLR connection and standard mic (2-core screened) audio cable. It follows the AES (Audio Engineering Society) digital audio standard and can connect to any equipment fitted with an AES input socket. The source to this output is patched using the **Setup / Audio / Output Patch** screen. Applications include the feed to a PA speaker processor, amplifier, stereo broadcast or recording device equipped with AES input.



Alt Out – Stereo ‘alternative’ output on balanced TRS jacks for connection to +4 or 0dBu equipment such as zone feeds, fill speakers, broadcast or local monitor. The source to this output is patched using the **Setup / Audio / Output Patch** screen.

2TRK Out – Stereo output on balanced TRS jacks for connection to +4 or 0dBu equipment such as stereo recorders. It follows the post master fader main LR mix.

4.3 Other Connections



Lamp – Plug in a 4-pin gooseneck lamp to illuminate the mixer surface. We recommend the Allen & Heath LEDLamp with built-in thumbwheel dimmer.



USB B – Type B USB socket for multi-channel bi-directional audio streaming between the mixer and a computer. Follows the high speed USB 2.0 standard.

Firmware V1.0 supports connection to an Apple MAC only. Windows PC drivers are currently not available.



Network – Fast Ethernet (100 Mbit/s) port for CAT5 cable connection to a computer for MIDI over TCP/IP control of mixer parameters, or to a wireless router (access point) for live mixing control using the Allen & Heath Qu-Pad app running on an iPad. The **Lnk** indicator flashes to indicate network activity.

The Qu-Pad app is not supported by firmware V1.0.



dSNAKE – The proprietary Allen & Heath ‘digital snake’ connection for remote audio using the AR2412 AudioRack, and personal monitoring using the ME system.

dSNAKE is not supported by firmware V1.0.

4.4 Powering up the mixer

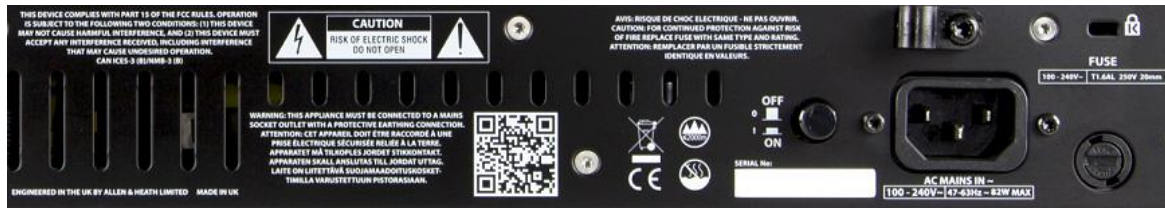

The Qu has a built-in universal voltage power supply unit. This means you can use your mixer in most parts of the world without the need to modify the unit as long the local mains supply is within:

Mains Voltage = 100 to 240 V.AC

Mains Frequency = 47 to 63Hz

Important - Before starting, read the **Safety Instructions Sheet** packed with the mixer. These can also be downloaded from the Allen & Heath web site.

Also read the safety notes printed on the rear of the mixer.

AC MAINS IN – Standard IEC socket for connecting the mixer to the local mains supply. Plug in a mains lead with moulded plug suitable for your territory. A suitable mains lead is shipped with the mixer.

Note – Do not replace the mains plug or modify the lead in any way. For your own safety and that of the operator and performers do not remove or defeat the ground connection.

A **cable clamp** is provided. You can slot the cable into this or lock it in place. To lock the cable use a star head Torx T20 screwdriver to refit the clamp around the cable.

Fuse – Mains input fuse to protect the mixer circuits in the unlikely event of a failure or excessive power surge. If you need to replace the fuse always use one of the same type and rating as printed on the rear panel. If the replacement fuse blows then refer to your authorised Allen & Heath service agent for advice.

Power ON/OFF switch – Press to switch the mixer on. Press again to switch it off.

Switching the mixer on – Press the ON/OFF switch. The rear panel blue Power indicator lights. The mixer takes just a few seconds to boot up. It restores its previous settings. CH1 is selected and its processing shown on the screen.

Note – To avoid loud thumps do not switch the mixer on or off while the PA speakers are turned on. Always switch the amplifiers on last, and switch them off first.

Switching the mixer off – First select the **Home** screen. Touch **Shut Down** to safely complete processes such as parameter storing and USB data transfer or recording. Once complete, press the ON/OFF switch.

5. Operational Overview

This section provides an overview of the Qu-16 layout and operation to help you get started quickly.

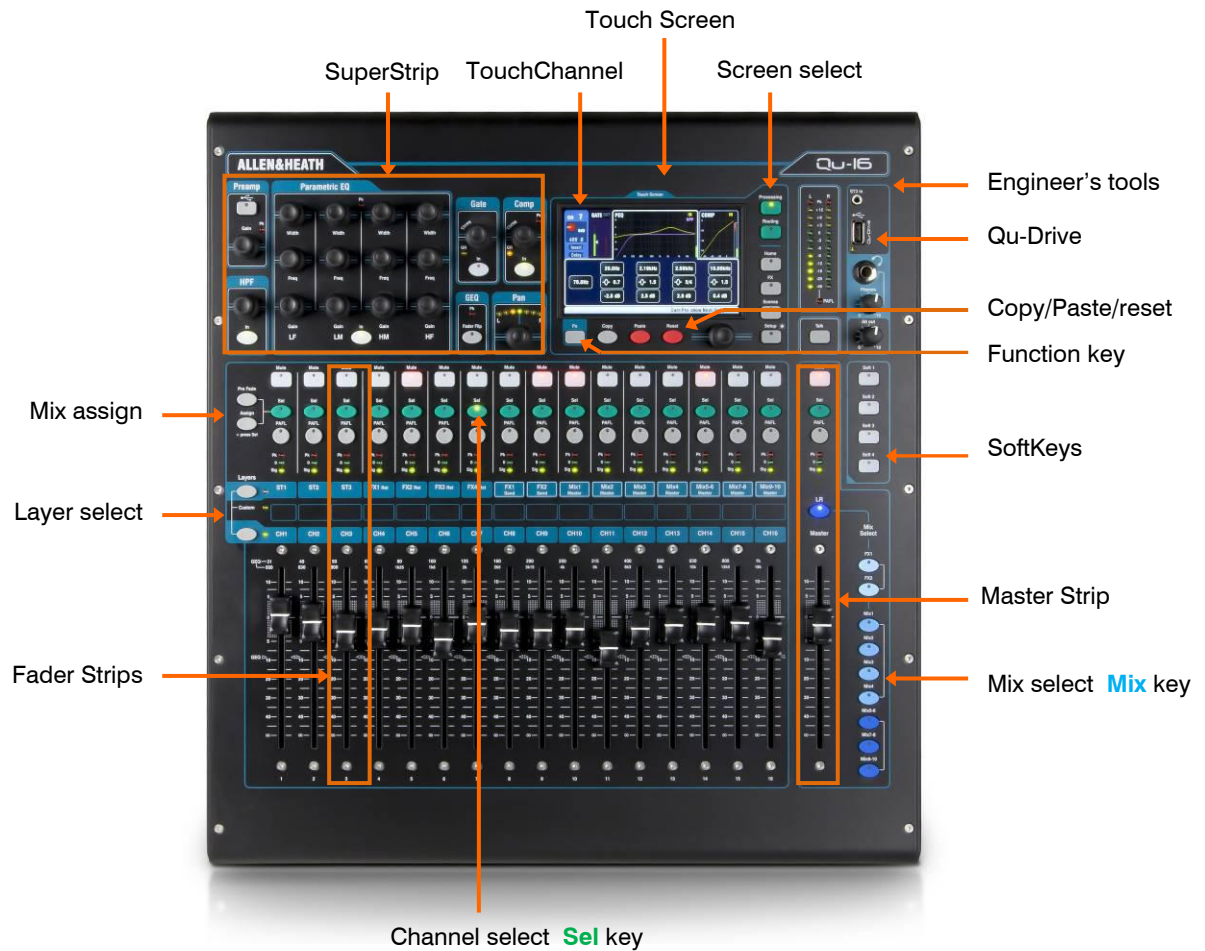

5.1 Fader Strips



The Qu-16 has a group of 16 fader strips. These provide access to the input and master channel levels and processing.

The main channel levels, master levels and all sends to the effects and mixes can be easily viewed and adjusted using the faders. The faders can also be used to adjust the Graphic EQ while in Fader Flip mode.

The faders are motorised and instantly move to show the current settings when the layer or function is changed.

Layers – There are two Layers. These provide access to 32 strips identified by the labels alongside the layer select keys.

Press the lower key to access the 16 mono channels.

Press the upper key to access the 3 stereo channels, FX returns, FX send and Mix masters.

Press both keys together to access the user assignable Custom layer (Not supported by V1.0).



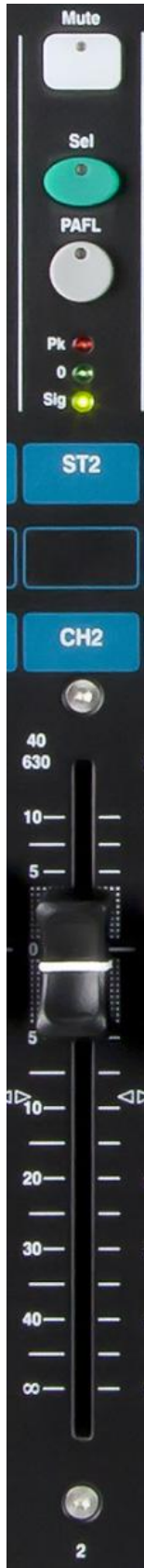

Mute key – Press to turn off the channel audio signal. This affects the send to all mixes including LR, effects and stage monitors. The Mute key lights red when the channel is muted. It flashes when it is muted by a Mute Group master.

Sel key – Press to access the **Channel Processing**. Parameters can be adjusted using the SuperStrip controls. The Touch Screen will display the settings and provide additional controls if either the **Processing** or **Routing** screen is active.

The Sel key is also used to:

Assign mix routing – Hold down the Assign key and press Sel keys to assign channels to the mix currently selected in the Master Strip. The Sel keys light green for channels assigned to the selected mix.

Assign Pre/Post fade sends – Hold down the Pre-Fade key and press Sel keys to toggle channel sends pre or post fader for the mix currently selected in the Master Strip. The Sel keys light green for channels set pre-fade.

Copy channel processing – Hold down the Copy key and press a channel Sel key to copy its processing settings. Then hold down the Paste key and press one or more Sel keys to instantly paste those settings to other channels.

Reset channel processing – Hold down the Reset key and press a channel Sel key to instantly reset all its processing to factory default.

PAFL key – Press to listen to a channel using headphones and check its level on the main meters. The meter PAFL indicator lights. Press PAFL again to turn it off. A SoftKey can be assigned to Clear All active PAFL selections.

Options are available in the **Setup** screen to choose how you want PAFL to work:

Auto-cancel – Listen to one channel at a time.

Additive mode – Listen to more than one channel at a time.

PFL (pre-fade listen) – Monitor the signal before the fader, for example to check it and set its gain before you bring up the fader. This is the default.

AFL (after-fade listen) – Monitor the signal in stereo after the fader and pan controls so that you can hear its contribution and position in the LR mix.

Sel follow PAFL – Link the Sel switch so that pressing PAFL automatically selects the processing for that channel.

LR to PAFL – Routes the main LR mix to the monitor when there is no PAFL selected.

Channel meter – The strip meters let you keep an eye on signal levels while you are mixing. These display channel level before the fader and mute control:

Pk – Lights red to warn that the signal is too hot and gain or trim should be reduced. It turns on 3dB before clipping to warn you before audible distortion. Pk senses the signal at several points within the channel.

0 – Lights when the signal reaches nominal 0dBu allowing a healthy 18dB headroom. This is the normal level for mixing.

Sig – Lights to show signal presence. It turns on at -26dBu.

Fader – Controls the level of the input channel, FX or mix master assigned to it. This can be the main channel fader or a send to an effect or mix depending on which Mix Select key is active in the Master Strip.

The faders can control the Graphic EQ frequency bands while in GEQ Flip mode with a mix master Sel key active. The range of frequencies accessed by the faders is highlighted in the touch screen and labelled at the top of the faders. The centre 0dB flat position is marked on the fader scale.

5.2 Channel Processing

The **SuperStrip** provides familiar, analogue feel, one function per knob control of channel and mix master processing such as equalisers and dynamics. The Touch Screen displays the parameter values and provides additional related controls while in the **Processing** screen. This processing is accessed using the fader strip **Sel** keys.



The following processing is available:

Mono input CH1-16 = Source, Preamp, HPF, Gate, PEQ, Compressor, Delay, stereo Linking

Stereo input ST1-3 = Source, Trim, HPF, Gate, PEQ, Compressor, Delay

FX Return 1-4 = FX parameters, PEQ

Mono Mix1-4 = Graphic EQ, Compressor, Delay

Stereo Mix5-10 = Parametric EQ, Compressor, Delay

Main LR = Graphic EQ, Compressor, Delay

5.3 Working with the Processing:



- Press a fader strip **Sel** key. The Processing Block controls become active for that channel.
- Press the **Processing** key to work with the parameters on the Touch Screen.
- Touch the top part of the Touch Screen to open the tabs for the available processing blocks.
- View values in the lower part of the screen. Touch screen buttons and use the screen rotary to adjust parameter values.



Preamp

An analogue preamplifier ('head amp') matches each connected microphone or line signal to the operating level of the console before it gets converted to digital to be processed and mixed with the other channels.

Turn on **48V** if the connected device requires phantom power, for example a condenser microphone or active DI box. Touch and hold for 1 second to toggle on or off. This prevents accidental operation.

Note - To prevent audible thumps make sure the channel is muted before switching 48V on or off.

Turn up **Gain** so that the average loud signal reads into the yellow of the meter. Turn down if any red peak light flashes.

Touch **Ø** to reverse the polarity of the input signal, for example the lower mic when working with two microphones on a snare drum.

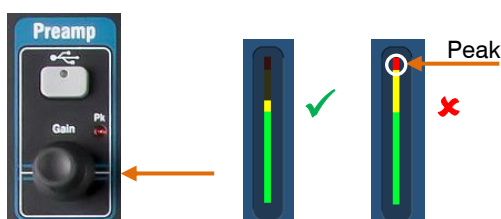

Other functions in the Preamp section

Insert switches an internal FX in or out if one has been patched into the channel. The button is disabled when the insert is not patched. The FX is inserted between the preamp and EQ.

Use the **FX / Back panel** screen to choose and assign one of the 4 internal FX as an Insert into a channel.

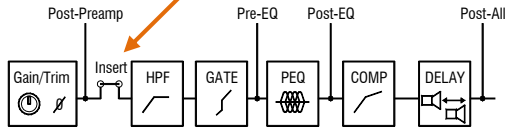
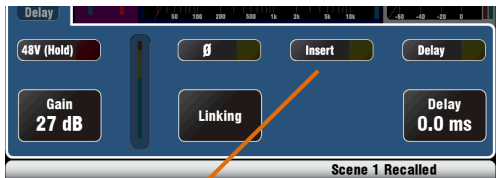

Delay up to 85ms can be added to each input channel. In most cases delay is not needed, but can be useful in time aligning sound from the PA to the acoustic sound from an instrument on stage. Allow 1ms per foot distance as a starting point.

Linking lets you gang the preamp, processing and routing of an odd/even mono channel pair for stereo operation. All parameters including the preamp, processing and routing are linked. Pan becomes a width control when linked. Some parameters can be removed from the link using the buttons:

- Preamp – Gain/48V, Polarity
- Dynamics (Compressor and Gate) - Side Chains
- Main mix – Fader/Mute, Pan

Touch **Apply** to accept your changes.



The **USB Source** key in the Preamp control block selects the input source to the channel - either the analogue Mic/Line input or the USB digital source. Use the **Home / USB Audio** screen to set a range of channels and choose the Qu-Drive or USB B streaming as the global digital source.

For digital sources (USB) and stereo ST1-3 line inputs Gain is replaced with a **Trim** control providing +/-24dB range. The red knob in the screen changes to blue for digital sources.

Gate

The Noise Gate can be switched in to dynamically turn off the audio when it drops below a certain level. For example, to reduce resonant decay of a kick drum or floor tom, or hiss of a noisy keyboard.

Use the **In** key to switch the Gate in or out. This is similar to inserting an outboard rack mounted device into the Insert socket on an analogue console channel.

Set **Depth** for how much signal reduction you want when the gate closes. 20dB is a typical setting. Sound check the instrument and reduce **Threshold** to shut off as much of the tail of the signal as you want. The **GR** indicator lights and red screen meter shows the amount of reduction when the gate is closed.

Hold sets how long the gate remains open after dropping below the threshold. **Attack** sets how fast the gate opens when the signal rises above the threshold. **Release** sets how fast it closes when dropping below the threshold. Experiment with these controls to achieve smooth operation without a pumping effect.

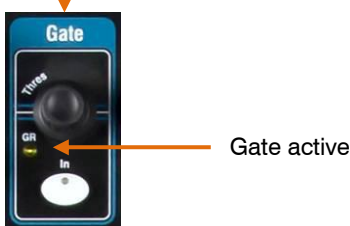
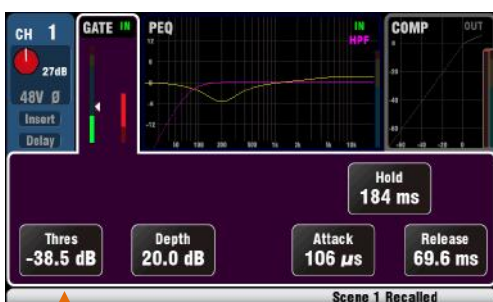

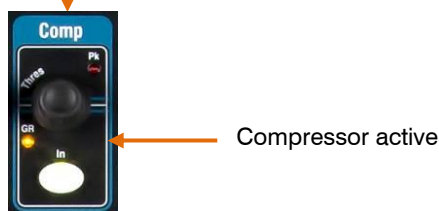
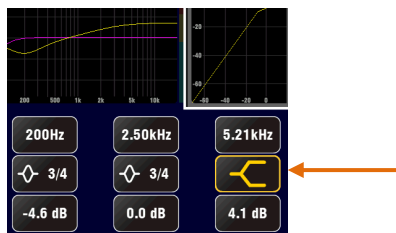
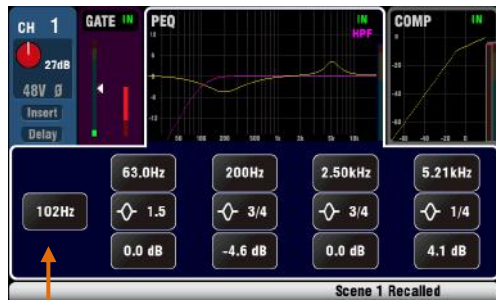

HPF

The High Pass Filter is used to reduce unwanted low frequency sounds such as vocal popping, wind noise and stage rumble.

Switch the HPF in using the **In** key. Use the panel rotary or screen button and rotary to sweep the cut-off frequency until you have reduced the unwanted sound. The filter has a 12dB slope and can be swept from 20Hz to 2kHz. The violet screen curve shows the resulting frequency response.

PEQ (parametric equaliser)

The Parametric Equaliser allows tonal adjustment of the channel sound. It splits the 20Hz to 20kHz audio frequency range into 4 bands:

- LF (low frequency)
- LM (low mid frequency)
- HM (high mid frequency)
- HF (high frequency)

Each provides 3 parameters that can be adjusted:

Gain – Boost or cut frequencies by up to 15dB. Centre 0dB is flat response (no affect).

Frequency – Each band can sweep its centre point frequency across the full range from 20Hz to 20kHz. This means you can overlap bands and have more precise control over problem frequency areas.

Width – Each band has a bell-shaped response. The width of the bell can be varied from a very wide 1.5 octaves affecting many frequencies to a very narrow 1/9th octave affecting a small range of frequencies. Setting LF or HF to widest position changes its response to shelving.

Experiment with the controls to hear their affect on different sounds. Switch the PEQ in or out using the **In** key to compare the sound. It is better to cut rather than boost frequencies where possible.

Compressor

The Compressor is a powerful tool for controlling the dynamics of the sound, for example to smooth out a bass guitar or to narrow the dynamic range of a vocal to make it more intelligible in a busy mix. At its extreme setting the compressor can be used as a limiter to prevent the signal exceeding a preset maximum level.

A compressor works by dynamically reducing the amount of gain when the signal increases above a certain threshold. This pulls back loud moments. Applying 'make-up' gain restores the average volume and also has the effect of bringing up quiet moments. The result is a reduced dynamic range.

While listening to the signal adjust **Thres** (threshold) to set the point at which compression starts. The GR indicator and red screen meter will start to show that compression is active. Set **Ratio** for how much compression you want from none (1:1) to full limiting (Inf). A good starting point is around 3:1.

Use the **In** key to switch the compressor in and out and turn up **Gain** so that the average volume is similar.

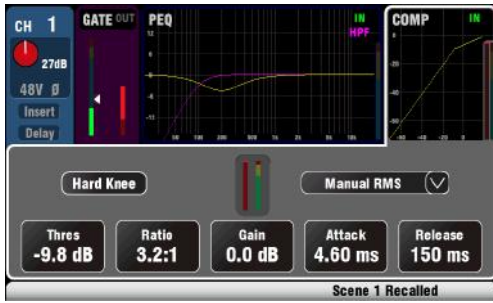

Attack sets how fast the compressor starts to work when the threshold is reached. **Release** sets how fast it stops compressing when the signal drops below the threshold. For example, adjust these to achieve a 'punchy' dynamic sound, or smooth out the response to reduce an audible 'pumping' effect.

Two 'knee' settings are available. **Hard Knee** means that compression is applied at the set ratio as soon as the threshold is reached. **Soft Knee** means that the compression ratio increases gradually from 1:1 to the set ratio as it approaches the threshold. The curve illustrates this.

4 Compressor types are available using the drop-down menu. Two 'Manual' types allow user control of attack and release. Two 'Auto' types provide automatic control of the compressor dynamics.

Experiment with the effect of the compressor settings on different sounds. Try to use compression only where it is needed, and avoid compression in stage monitor speakers.

Mix processing

The mix masters provide EQ, Compressor, FX Insert capability and output Delay.

Insert switches an internal FX in or out if one has been patched into the mix. The button is disabled when the insert is not patched. The FX is inserted at the start of the processing before the EQ.

Use the **FX / Back panel** screen to choose and assign one of the 4 internal FX as an Insert into a mix.

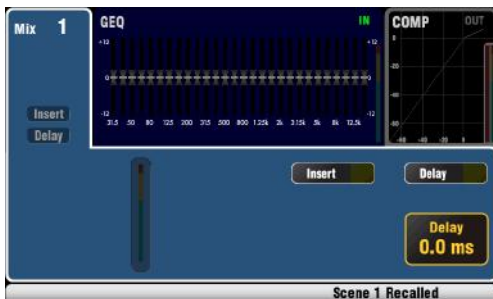

Delay up to 170ms can be added to each mix output. This is typically used to time align the PA to the acoustic sound from the instruments on stage, or to align fill loudspeakers to the main PA. Allow 1ms per foot distance as a starting point.

GEQ (graphic equaliser)

A GEQ is provided on each of the 4 mono mixes and the main LR mix as these are likely to feed stage monitors and PA speakers where traditional graphic equalisation is popular. A PEQ is provided on each of the 3 stereo mixes where more precise parametric equalisation may be preferred for in-ear and other sends.

The Graphic Equaliser allows tonal adjustment of the overall mix sound. It splits the 20Hz to 20kHz audio frequency range into 28 standard 1/3 octave bands from 31.5Hz to 16kHz allowing +/-12dB cut or boost.

Touch the **In** button to switch the GEQ in or out. Touch a slider to highlight it and use the **screen rotary** to cut or boost its frequency. This affects a small range of frequencies 1/3 octave wide centred on the frequency marked below the slider. The position of the sliders shows the approximate shape of the resulting frequency response curve.

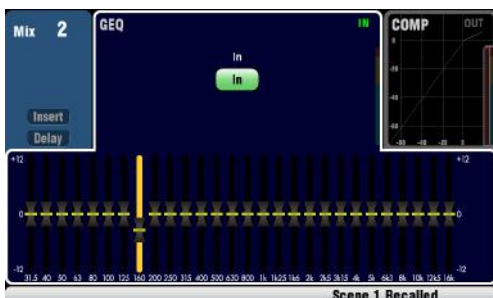

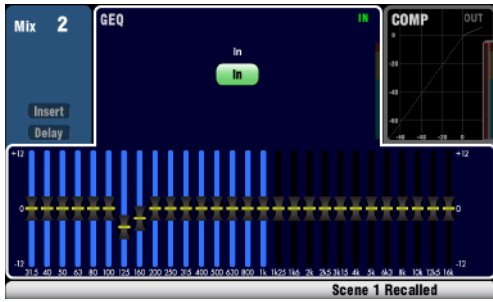

Press the **GEQ Fader Flip** key to view and adjust the GEQ on the faders while a mono or the LR mix is selected. The screen highlights the active range of frequencies. Press the switch again to change range or return to normal mix mode.

The fader strip **Sel** key turns on when the slider is at 0dB mid (flat) position while in fader flip mode. Press a **Sel** key to return a slider to 0dB.

It is better to cut rather than boost frequencies when tuning speakers using the GEQ.

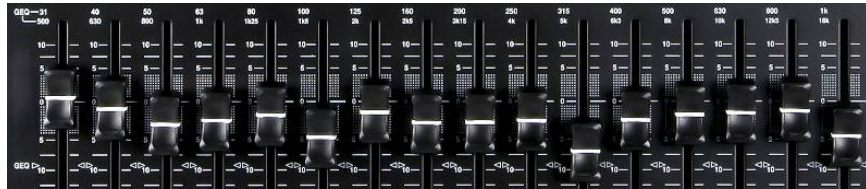

5.4 Channel Routing

The Touch Screen presents tabs to access the channel assignments and send levels when its fader strip **Sel** key is selected and the Touch Screen **Routing** screen is active. The Channel Block **Pan** control provides quick access to the related mix pan setting for the channel. The **Fn** key is used to access the Mute Group masters while in any Routing screen.



5.5 Working with the Routing screens:



- Press a fader strip **Sel** key.
- Press the Touch Screen **Routing** key.
- Touch the tabs at the top of the screen.
- Touch screen buttons and use the rotary.
- Press the **Fn** key to access the Mute Groups.

Pan

The rotary Pan control becomes active when an input channel **Sel** key is active. Its function depends on currently selected Master Strip mix:

- LR = Channel main pan
- FX send = Channel main pan
- Mono Mix1-4 = Disabled
- Stereo Mix5-10 = Channel send pan

Pan becomes a Width control when linked for two input channels – Panning one to the left automatically pans the other by the same amount to the right.



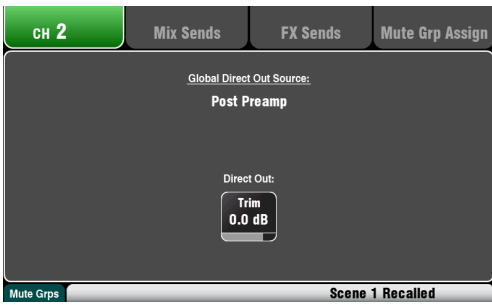

Channel Routing screen

Adjust the channel Direct Output **Trim** from off to +10dB gain. The Direct Outputs can be patched to feed the internal FX devices, for example a delay effect send for a single vocal.

The channel source for the Direct Outputs is displayed on this screen. This is a global setting affecting all direct outputs. It can be changed using the **Setup / Audio / Global** screen.



Channel Mix Sends screen

Use this screen to work with the sends and assignments from one channel to all the mixes.

Each send can be set **Pre** or **Post** fader. It is typical to set monitor sends pre-fade so that the channel fader does not affect the monitor mixes, and to set effects and fill speaker sends post-fade so that their levels do follow the faders.

The channel can be assigned (routed) **On** or **Off** to each mix. Touch the **Level** and **Pan** buttons and use the screen rotary to adjust their settings.

To work with the sends and assignments from all channels to one mix use the Master Strip **Mix** keys and the fader strips.



Channel FX Sends screen

Use this screen to work with the sends and assignments from one channel to FX1 and FX2. These are for Mix>Return effects such as reverb and delay.

The sends can be set **Pre** or **Post** fader but it is usual to leave these set post-fade so that the effects follow the channel fader level. Each send can be assigned **On** or **Off**. Its **Level** can be adjusted here.

To work with the sends and assignments from all channels to one FX mix use the Master Strip **Mix** keys and the fader strips.

FX3 and FX4 do not have dedicated sends. However, you can assign any of the Mix1-10 buses to feed these effects. To do this use the **FX / Back panel** screen.

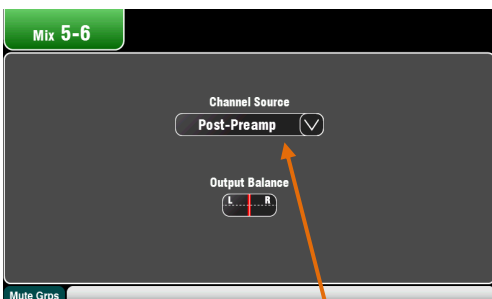

Mix Routing

Select a mix master **Sel** key while the **Routing** screen is active to:

Adjust the **Output Balance** between L and R of a stereo mix.

Choose the global **Channel Source** for the selected mix. This is the point in the channel signal path that feeds the mix.

Choose Pre-EQ for a monitor mix if you do not want the channel EQ to affect the monitor.

Choose Post-EQ if you want the EQ but not the compressor to affect the monitor.

Choose Post-All for effects sends.

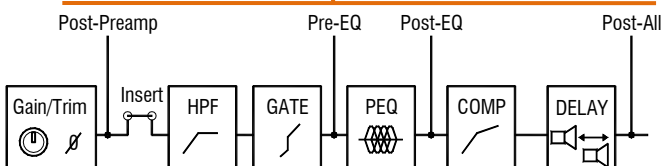

5.6 Mute Groups

The Qu features 4 Mute Groups. You can assign channels to a Mute Group so that pressing its master key will instantly mute all assigned channels. For example, mute all drum channels, mute all mics on stage during band changeover, or mute all FX returns between songs. Mute masters are accessed from the **Home** or any **Routing** screen, or using the SoftKeys.

The following may be assigned to Mute Groups:

- Mono and stereo Input Channels
- FX Send masters
- FX Return channels



Assigning a single channel

Press an input channel or FX send or return fader strip **Sel** key and select the Touch Screen **Routing** screen. Open the **Mute Grp Assign** tab. Use this screen to assign the channel to any combination of the 4 Mute Groups.

A green tick next to the button indicates that the Mute Group master is available on the related SoftKey.



Assigning all channels

While in any **Routing** screen press the **Fn** key to open the Mute Groups view.

Select the tab for the Mute Group you wish to assign. All sources to that group are shown. Touch buttons to toggle assignments on or off. Touch the Clear/Set All button to turn off or on all the assignments.

Press the **Fn** key again to close the Mute Groups view.

5.7 Using the Mute Groups



There are 3 ways to use the Mute Groups:

- Touch the master buttons on the **Home** screen.
- While in any **Routing** screen press the **Fn** key to open the Mute Groups view. Select the **MG Masters** tab and touch the master buttons.
- Assign and use one or more **SoftKeys** as Mute Group masters. The Mute Groups are assigned to SoftKeys with the same number as the group.

The Mute key will flash red if the channel is muted by a Mute Group. A short flash shows it is muted by the group only. A long flash shows it is muted by the Mute key and a group.

5.8 The Master Strip

Qu provides a dedicated fader strip for the Mix Masters. It presents the fader and controls for the mix currently selected using the **Mix** keys alongside. The sends to the selected mix are presented on the 16 faders. They move to show the current settings. This provides a very quick way to access each mix without the need to switch to the Masters layer.

Mute key – Press to turn off the mix master audio signal. The Mute key lights red when the audio is muted.

Sel key – Press to access the **Mix Processing**. Its PEQ and Compressor parameters can be adjusted using the SuperStrip controls. The Touch Screen will display their controls and settings and provide access to the GEQ and routing options if either the **Processing** or **Routing** screen is active.

The Sel key can also be used to:

Copy mix processing – Hold down the Copy key and press the Sel key to copy the processing settings. Then select a different **Mix**, hold down the Paste key and press the Sel key to instantly paste those settings to that mix.

Reset mix processing – Hold down the Reset key and press the Sel key to instantly reset all its processing to factory default.

PAFL key – Press to listen to a mix using headphones and check its level on the main meters. The meter PAFL indicator lights. Press PAFL again to turn it off. A SoftKey can be assigned to Clear All active PAFL selections. Options are available in the Setup screen to choose how you want PAFL to work. The default setting is **AFL** (after-fade listen).

Mix meter – The strip meter lets you keep an eye on the mix master signal level. This is 'post-fader' and displays the level after the fader and mute control to follow the signal available at the output of the mixer.

Pk – Lights red to warn that the signal is too hot and mix level should be reduced. It turns on 3dB before clipping to warn you before audible distortion.

0 – Lights when the signal reaches nominal 0dBu allowing a healthy 18dB headroom. This is the normal level for mixing.

Sig – Lights to show signal presence. It turns on at -26dBu.

Fader – Controls the level of the mix master currently selected. There is +10dB boost available. Normal setting is around the '0' position.

Mix Select keys – These select which mix master is presented on the master strip. Only one can be active at any time. Press a key to select it. Press it again turn return to the main LR mix.

LR sets the strip to control the main LR mix. This is the normal selection for mixing the FOH (main PA) sound.

FX1-2 sets the strip to control the FX1 or FX2 internal effects send master. The channel faders move to become the sends to the selected FX. Channels can be assigned using the Sel keys.

Mix1-10 sets the strip to control one of the mono or stereo mix masters. The channel faders move to become the sends to the selected mix. Channels can be set pre or post-fader and assigned using the Sel keys.



5.9 Working with the sends on faders:



- Press a **Mix** key. The master strip presents the mix fader and controls. The 16 channel faders move to present the sends to that mix.
- Move a channel fader to adjust its **send level** to the selected mix.
- Hold the **Assign** key to view the current channel assignments to the mix. The Sel keys light when the channel is assigned (routed) to the mix. To toggle the assignments on or off, press channel **Sel** keys while holding Assign.
- Hold the **Pre Fade** key to view the current channel pre/post fade settings for the mix. The Sel keys light when set to Pre-fade. To toggle pre or post, press the channel **Sel** keys while holding Pre Fade. It is typical to use Pre-fade for monitor sends and Post-fade for effects sends.
- Press the **Mix** key again or press **LR** to return to the main mix, or press another **Mix** key to adjust a different mix.

Note Always remember to return to the main LR mix once you have finished adjusting monitor or effects levels.



5.10 Copy, Paste, Reset keys

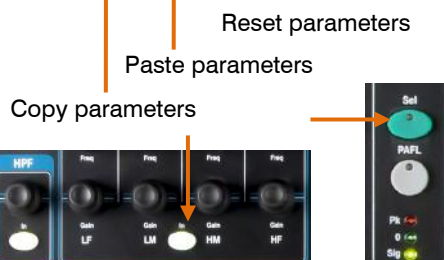

Press + hold down one of these keys and then press another key or screen item to copy, paste or reset the related parameters. For example:

Copy – Press Copy + a channel **Sel** key to select its processing to copy. Press Paste + another channel **Sel** key to paste the processing to that channel.

You can copy just one processing block such as PEQ using its **In** key and then paste it into other channels using their strip **Sel** keys.

Reset – Press Reset + a channel **Sel** to instantly reset its processing to factory default settings.

The following Copy/Reset is supported:

- + Input strip **Sel** key = HPF, Gate, PEQ, Comp, Delay
- + Mix strip **Sel** key = PEQ, GEQ, Comp, Delay
- + HPF **In** key = HPF only
- + PEQ **In** key = PEQ only
- + Gate **In** key = Gate only
- + Comp **In** key = Compressor only
- + touch **Scene** item in list = Scene contents

6. Touch Screen Mixing Functions

The Qu features an 800x480 pixel, full colour touch screen for quick and intuitive setup and control of the mix.

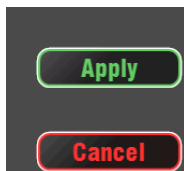
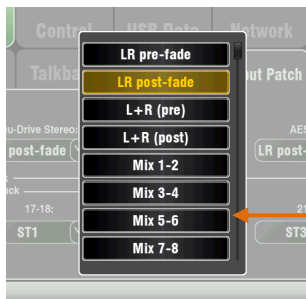

Button – Touch to select its function or change its state. To avoid accidental operation some functions need be touched for at least 1 second, for example switching phantom power. These are marked '(Hold)'.

Parameter box – Touch to change its value. The box highlights orange to show it is selected and can be adjusted using the screen rotary.

Option Menu – Touch to open a list of options available. Scroll using the screen rotary and touch an item in the list to select it. Touch outside the box to exit. Several menu lists are available within the screens, for example, to choose the source for the AES output.

Screen Rotary – Use this to change the value of the parameter in the box highlighted orange on the screen, or to scroll through lists.

Apply / Cancel – Some setup screens present several parameters associated with one function, for example channel linking. These can be chosen before they are applied. Touch **Apply** to accept the changes or **Cancel** to close the screen without accepting the changes.

Function Key – The **Fn** key provides access to further options associated with the currently selected screen. If available, its function will appear in the lower toolbar above the key. Press the key again to close the option screen.

This example shows access to the **Mute Groups** screens from within a Routing screen.

6.1 The Sel screens – Processing and Routing

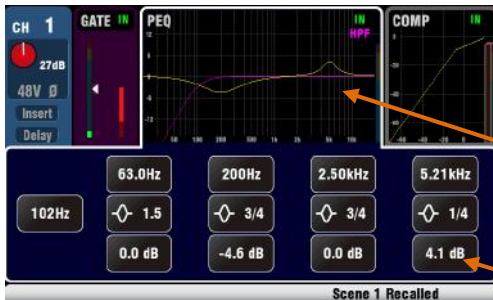

Processing Screen – When selected this screen presents the processing such as Preamp, EQ, Gate, Compressor for the channel or master currently selected using its strip **Sel** key.

Touch the **top part** of the screen to select the processing block you wish to view or adjust, for example Preamp or PEQ. This is known as the **TouchChannel**.

The **lower part** of the screen changes to provide access to the related parameters and additional related controls.

The physical controls in the **SuperStrip** and the touch controls in this screen provide quick access live mixing functions.



Routing Screen – When selected this screen lets you access the assignment and routing for the channel or master currently selected using its strip **Sel** key.

This lets you work with routing to all mixes from one channel. To work with all channels to one mix use the Master Strip **Mix** keys and sends on faders.

6.2 Home Screen



Press the **Home** key. Pressing it again restores the last selected **Sel** screen. The Home tab presents:

- Current Firmware version
- Current User
- The 4 Mute Group master buttons
- **Shut Down** button to use before powering down the mixer
- **Lock Surface** to protect settings when the mixer is left unattended

6.3 Home Screen – Changing User

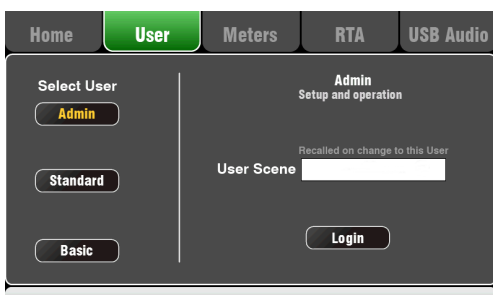

This screen lets you log in as one of 3 Users with different permissions:

- **Admin** – Full access to all functions
- **Standard** – Operation only, setup not allowed
- **Basic** – Fader and Mute control only

Firmware V1.0 does not support User Permissions. The only user available is Admin.

6.4 Home Screen – Meters

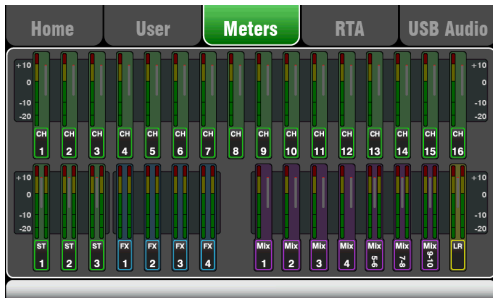

This screen provides a convenient view of all channel, mix and FX signal activity.

For optimum performance the loudest signals should read into the yellow. If any red Peak meter flashes then reduce the level of that signal to avoid possible distortion. Increase levels if the meter readings are consistently low.

6.5 Home Screen – RTA

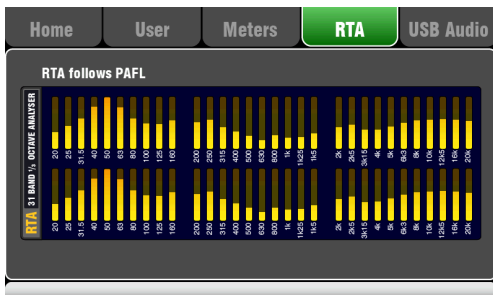

This screen displays a Real Time Analyser (RTA) which analyses the frequency content of the audio signal currently being monitored using the PAFL keys.

It splits the frequency into 31 third octave bands from low 20Hz to high 20kHz, the same frequencies as used on a graphic equaliser.

The RTA is a useful tool to help you identify problem frequencies such as room resonance and feedback.

6.6 Home Screen – USB Audio

This opens three screens associated with the USB stereo and multitrack recording:

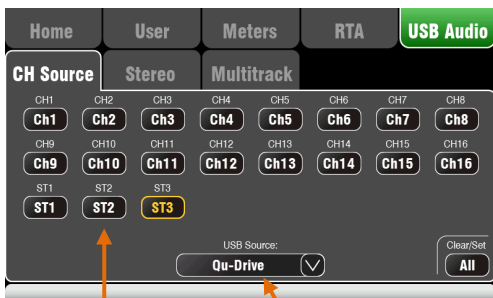

CH Source page – The input channels can be sourced from the analogue preamp or USB playback. This screen presents a view of the source settings for all channels. Each button is the same as the USB source key in the physical Preamp section.

You can set any combination of channels for USB playback or turn them all on or off using the Clear/Set All button.

Use the **USB Source option** to choose which USB port feeds the source switch. This can be either the Qu-Drive (top panel USB port) or USB B streaming (rear panel USB port).

Depending on the switch settings and option the following channel sources will be patched:

Channel	Off	Qu-Drive	USB B
CH1-16	XLR/Jack	Trk1-16	Stream1-16
ST1	Jack	Trk17-18	Stream 17-18
ST2	Jack	none	Stream 19-20
ST3	Mini-jack	Stereo	Stream 21-22

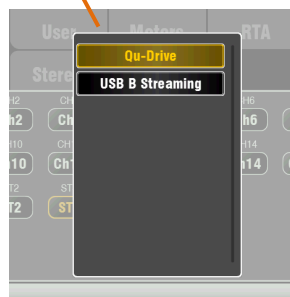



Qu-Drive Stereo page – This screen presents the controls for stereo recording to and playback from the top panel Qu-Drive port.

The blue Stop buttons light if the USB key or drive is recognised by the mixer. The controls are disabled if not plugged in or recognised.

Stereo Record – You can record to a USB hard drive plugged into Qu-Drive:

- Format = 48kHz, 24-bit, WAV file
- Data rate = 288 KB/sec, maximum 4 hours (4GB)
- Qu allocates a file name 'QU-STnnn.WAV' where 'nnn' increments from 001 to 999 starting at the highest number + 1 it finds on the drive.

Note – Use a USB hard drive, not a key, for all stereo and multitrack recording.

Note - Use the USB hard drive for the Qu mixer only. Do not use it for other applications.

* **Format the hard drive** on the Qu mixer before starting to record. Use the **Setup / Utility / Qu-Drive** screen. This clears the disk and sets up the Qu directory structure.

Patch the source to be recorded using the **Setup / Audio / Output Patch** screen Qu-Drive option menu. The record meter on the USB page displays the current source. The default is LR post-fade.

Arm the recording by touching the red circle Record button. Touch the Play button to start the recording.



Stereo Playback – You can play back audio files from a USB key or hard drive plugged into Qu-Drive:

- Format = 44.1 or 48kHz, 16 or 24-bit, WAV file

Note – Use the USB key or hard drive for the Qu mixer only. Do not use it for other applications.

Format the USB key or hard drive on the Qu mixer before loading the playback files. Use the **Setup / Utility / Qu-Drive** screen. This clears the disk and sets up the Qu directory structure.

Copy audio WAV files on to USB from your computer. Place these in the AHQU / USBPLAY directory. Plug the key or drive into Qu-Drive.

Patch the playback to the ST3 channel using the **Home / USB Audio / CH Source** screen. Select the ST3 button and select Qu-Drive in the 'USB Source' option menu.

Select the track to play back by touching the name box. You can choose a track from the Playback or the Recordings directory. Touch **Select** to confirm.

Press the Fn key for options to choose playback mode:

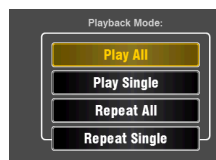
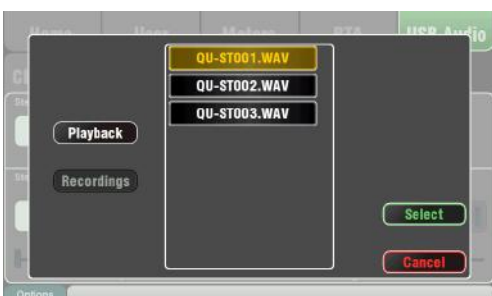
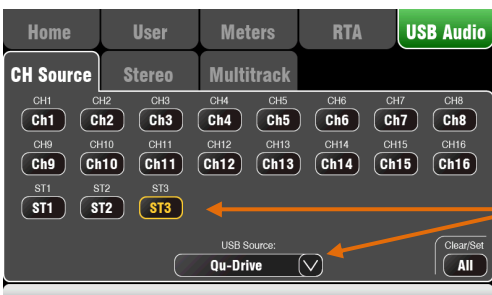
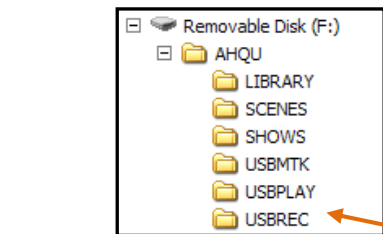

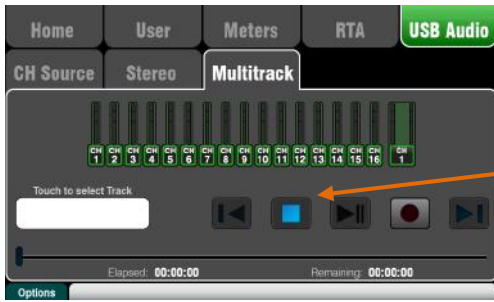

Qu-Drive Multitrack page – This screen presents the controls for multitrack recording to and playback from the top panel Qu-Drive port.

The blue Stop button lights if the USB drive is recognised by the mixer. The controls are disabled if not plugged in or recognised.

Multitrack Record – You can record to a USB hard drive plugged into Qu-Drive:

- 18 Tracks = CH1-16 and a patchable stereo
- Record format = 48kHz, 24-bit, WAV file
- Data rate = 144 KB/sec per track (max 4GB total)
- Qu allocates a folder name 'QU-MTnnn' for each recording where 'nnn' increments from 001 to 999 starting at the highest number +1 it finds on the drive. The tracks are named 'TRKnn' within the folder where 'nn' is 01 to 18.

Note – Use a USB hard drive, not a key, for all stereo and multitrack recording.

Note - Use the USB hard drive for the Qu mixer only. Do not use it for other applications.

Format the hard drive on the Qu mixer before starting to record. Use the **Setup / Utility / Qu-Drive** screen. This clears the disk and sets up the Qu directory structure.

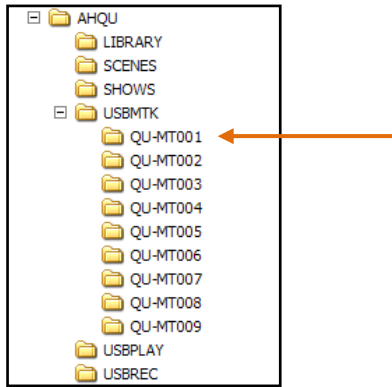

Patch the source to be recorded using the **Setup / Audio / Output Patch** screen 17-18 option menu. The default is the ST1 channel. Tracks 1-16 are mapped from CH1-16 insert sends.

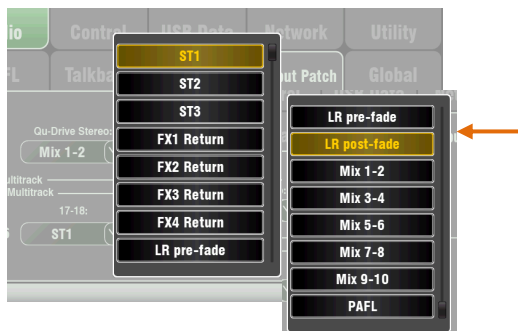

Arm the recording by touching the red circle Record button. Touch the Play button to start the recording.

Multitrack Playback – You can play back your multitrack recordings from the hard drive plugged into Qu-Drive:

Patch the playback to the input channels using the **Home / USB Audio / CH Source** screen. Select the Ch1-16 and ST1 button and check that Qu-Drive is selected in the 'USB Source' option menu.

Select the recording to play back by touching the name box. You can choose a folder from the list. Touch **Select** to confirm.

Press the Fn key for options to choose playback mode:

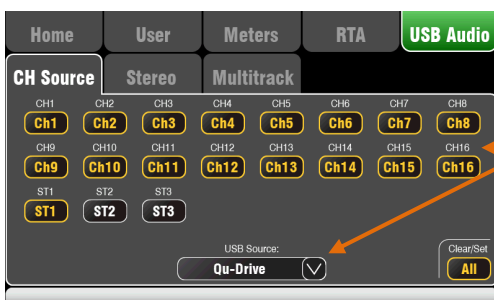

Note – Choose to play back either Qu-Drive stereo or multitrack. It is not possible to play back both stereo and multitrack at the same time.

6.7 The FX

Qu features 4 internal stereo FX (effects) processors. Each can be loaded from a library of different effects types and presets. These are the same as found in the flagship Allen & Heath iLive digital mix system and are based on emulations of popular industry standard effects.



Front Panel view



The FX screen

Press the FX key next to the Touch Screen to open the FX screen. You work with the FX in the same way you would with a traditional outboard rack. Start with an empty rack as shown here. Each of the 4 FX has a rack slot. Touch the tabs at the top to select each slot.

Library – Press the **Fn** key to open the Library page. Scroll through and select the FX type you wish to load into the rack. The effects are arranged in types on the left with available presets for each in the right hand window. Touch Recall to load the FX.

Listen to and experiment with the different presets and their parameters available.

FX types

Reverb – This is the most popular effect in live sound mixing. The SMR Live (Spatial Modelling Reverberator) features 4 fully configurable spatial models - Classic, Hall, Room and EMT plate. Each of these use different reflection and decay algorithms to add natural sounding space to the dry signal whether subtle small room echo, vintage vocal plate or a massive arena. Reverb can make a vocal sound spacious and smooth in the mix or add body to an instrument such as acoustic guitar or flute. There are plenty of factory presets available. The 4 buttons at the top control the main parameters if you wish to make adjustments. HF and LF cut shape the response, and Expert opens up a host of parameters for fine control if you wish to experiment further. You also have the 4-band PEQ available in the FX Return channel processing.

Delay – Generates separate left and right tap delay outputs from the input. Delay time can be dialled in using the screen rotary, tapped on screen or tapped using a SoftKey. The left and right delay taps can be linked to produce a mono effect. Feedback adds regeneration for a repeating echo effect. Set a short delay time around 80 to 160ms for the classic slapback effect.

ADT - An Automatic Double Tracking module capable of creating short echo/chorusing, classic double tracking and 'slapback' tape delay loops. It includes a stereo width enhancer and auto panning within the stereo field. The ADT is perfect for creating classic doubling effects, thickening programme on stage or developing a stereo sound field as an alternative to chorusing.

Chorus - Chorus derives from the late 80's where different stereo field creation techniques influenced the sound of each chorusing unit. Chorus recreates the classics using 3 stereo-field emulations. These emulations can be switched in any combination creating many different stereo fields.

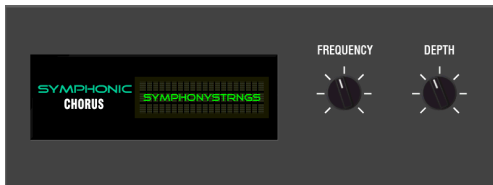

Symphonic Chorus - A faithful emulation of the 80's classic chorus effect. Simple to use and frequently requested. The unit has just two controls, Frequency and Depth controlling the rate and delay range of the stereo modulator. The unit produces a rich, lively and wide chorus sound with a suggestion of very mild phasing / flanging. Live engineers commonly use this for thickening vocals and strings and creating a spatial sound from a mono source. This has led to two factory presets 'SymphonicVox' and 'SymphonyStrings'.



Flanger - Qu provides three classic flanger effect emulations - 'Ambient', 'Vintage' and 'Wild'. During research of classic pedal flangers we found numerous LFO modulators and stereo splitting techniques. We implemented them all. For classic deep flange set Stereo Split and Stereo Spread off, pick triangular modulation, Vintage type and adjust Depth and Regeneration.

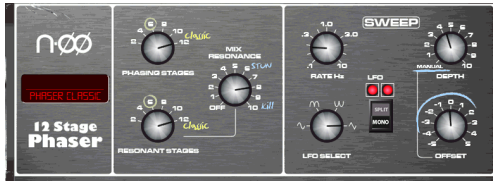

Phaser - A classic 12 stage emulation producing rich textured phasing with plenty of control. You can control the number of stages, feed forward and feedback, and 'zero' depth manual mode to manually sweep the Phaser using the offset control.



Gated Verb - An accurate emulation of the popular 80's Gated Reverb plus two other variants called 'Panned' and 'Powerbox'. The user interface gives instant access to Lo-cut Hi-cut decay spectrum filters and the gate envelope controls - pre-delay, attack, hold and release.

Back Panel view

Patching the FX

Touch the top right tab to select the Back Panel view. Open the option list to select the type of FX. Touch **Apply** to confirm any changes:



- **Mix>Return** - Known as a 'system effect' this uses a bus to Send a mix of the channels to the effect, and a dedicated stereo FX Return channel to add the 'wet' effect to the 'dry' original sound. This is used for effects such as reverb and delay. Choose which mix bus to use as its input. FX1 and FX2 have dedicated FX buses. If you want to use FX3 or FX4 as another system effect you could patch one of the Mix1-10 buses as its input.
- **Ch>Return** - This is similar to a Mix>Return system effect but fed from one channel rather than a mix of channels. It uses the assigned input channel Direct Output as its source. Examples include a vocal channel delay, gated verb on a snare, or chorus added to guitar.



- **Insert** - Here the effect is patched in line with an input channel or mix master. It is switched in or out using the channel Insert switch. Inserted FX provide a Dry/Wet control to balance the effect with the original signal.

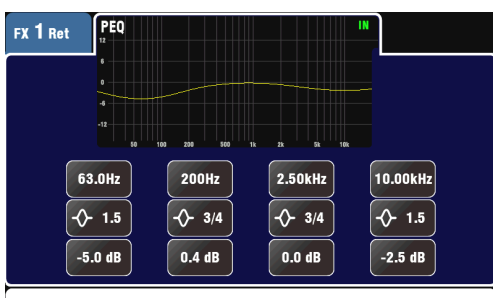

FX processing view

Press an FX Send or Return strip **Sel** key while the **Processing** screen is active to view and work with its parameters. Touch the top of the screen to open the PEQ view and adjust its return channel equaliser.

6.8 Working with FX – Adding vocal reverb:



- Press the FX key to open the **FX** screen. Touch to select FX1. Press the **Fn** key to open the Library page. Recall a Reverb into the FX1 slot if one is not already loaded. Open the Back Panel view and check that FX1 is set for Mix->Return with FX1 as its input.

- Start by turning up a vocal channel fader while the master strip **LR** mix is selected to hear the signal in the main PA mix.

- Select the top layer to view the FX Return channel strips. Set these faders to their '0' position and check they are unmuted to ensure the effect signals will be returned to the main mix.



- Press the **FX1** Mix key. The master strip now presents the FX1 Send master fader and controls. The 16 channel faders move to present the sends to FX1.

Sends on faders



- Press the master strip **Sel** key to view the FX1 parameters on the screen. Press the **Fn** key to open the library and recall a reverb preset.
- Set the master strip fader to its '0' position and check that it is unmuted to ensure the channel sends will be sent to the FX.
- Move the vocal channel fader to adjust its **send level** to the selected FX. This is similar to turning an Aux send knob on an analogue mixer to feed an outboard effects unit.
- You should now hear the reverb added to the dry vocal signal. Adjust the send fader for the amount of reverb you want. You can also send other channels to the reverb by turning up their send faders, for example backing vocals and instruments.
- When done, remember to return the faders to the main mix by turning off the **FX1** Mix key or selecting the **LR** key.
- You can assign the FX sends or returns to a **Mute Group** if you want to be able to turn off all the effects with a single key, for example between songs.
- You can assign a SoftKey as a **tap tempo key** for a delay effect. This lets you quickly tap in the beat for a vocal delay without the need to open the FX screen.

Use the FX Library to recall different effects types and presets. Listen to their effect of different signals and experiment with their levels and settings so that you can use them as a creative tool while mixing.

6.9 Scene Memories

Qu provides 100 Scene memories. These store and recall a snapshot of all live Mix parameters. Scenes have many applications. They can be used to store settings for bands during sound check for recall before they take to the stage during the show. Scenes can also be used for cue recall during theatre shows, or to provide a known starting point for different events or users in a multi-purpose venue.

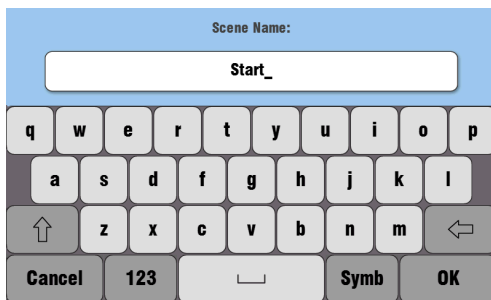

A Scene stores the following:

- Preamp settings
- Channel processing and linking
- Channel patch and routing
- Channel sends
- Channel mutes
- Channel faders/pan
- Mix processing
- Mix mutes
- Mix faders
- FX parameters
- Output patch
- Talkback assign and filter
- Mute Groups
- Custom strip assign (not in V1.0)
- SoftKey assign

A Scene does not store:

- PAFL settings
- Signal generator settings
- USB record/playback settings
- Scene preferences
- User profile settings
- Network settings

The Scenes screen

Press the Scenes key next to the Touch Screen to open the **Scenes** screen.

Scene list – Scroll through the list of 100 Scenes using the screen rotary. The currently selected Scene is highlighted. The last Scene recalled may be shown in the lower toolbar.

Name – Touch the Name box to open the screen keypad. Touch characters to name the selected Scene. Touch OK to accept.

A confirmation screen appears for the following functions:

Store – Touch this button to store the current mix settings to the Scene selected in the list.

Recall – Touch this button to instantly recall the scene overwriting the current mixer settings.

Reset Mix Settings – This provides a quick way to 'zero the board' by resetting the mix and processing to a typical starting point. To avoid accidental operation the button must be touched for 1 second or more to action the reset.

To Clear a Scene – Press and hold down the Reset key below the screen and then touch the Scene in the list. This clears the scene contents and name.

To Copy a Scene – Press and hold the Copy key below the screen and then touch the Scene to copy. Now press and hold the Paste key and touch the Scene in the list to paste to. This copies the scene contents and name.

The Global Filter screen

The Scene stores all mix parameters. A Recall Filter can be set to protect chosen parameters from being overwritten when the scene is recalled.

Note - The Scene Filter function is not available with first release firmware V1.0.

The Safes screen

The Scene affects all input channels, FX and mixes. You can set a selection of these 'Scene Safe' so that they are not affected by any scene recall. For example, walk-in music players and continuity microphones.

Note - The Scene Safes function is not available with first release firmware V1.0.

USB Scene transfer

Note – Scene transfer via USB key is not available with first release firmware V1.0.

Please check the Allen & Heath web site for the latest version of firmware and this user guide, and information on the Qu mixer.

7. Touch Screen Setup Functions

Press the Setup key next to the Touch Screen to open the **Setup** screens.



Touch the top tabs to access the different categories of setup function. Touch the tabs below to open up the related options available.

Dimmer – Turn the screen rotary while pressing and holding the Setup key to adjust the screen and surface LED brightness.

7.1 Audio Setup -PAFL

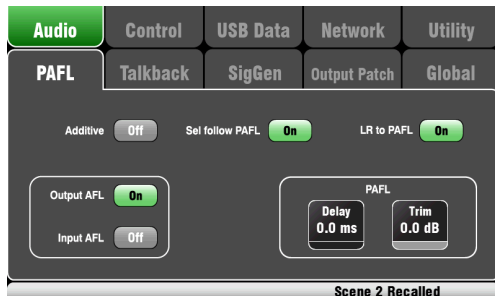

Choose how you want PAFL to work:

Additive mode – Select to listen to more than one channel at a time. Pressing a PAFL key adds to the previous selection. When off, the mode is Auto-cancel to listen to one channel at a time where pressing a PAFL key cancels the previous selection.

Input/Output PFL (pre-fade listen) – Monitor the signal before the fader, for example to check it and set its gain before you bring up the fader. This is the default.

Input/Output AFL (after-fade listen) – Monitor the signal in stereo after the fader and pan so that you can hear its contribution and position in the LR mix.

Sel follow PAFL – Link the Sel switch so that pressing PAFL automatically selects the processing for that channel.

LR to PAFL – Routes the main LR mix to the monitor when there is no PAFL selected.

PAFL Delay – Delay the monitor to time align it with the acoustic sound from the source when the mixer is a long distance away from the stage. Start with 1 ms per foot.

PAFL Trim – Attenuate the PFL (pre-fade) signal by up to 24dB to match it with the average AFL (after-fade) signal which is often much lower than PFL.

7.2 Audio Setup - Talkback

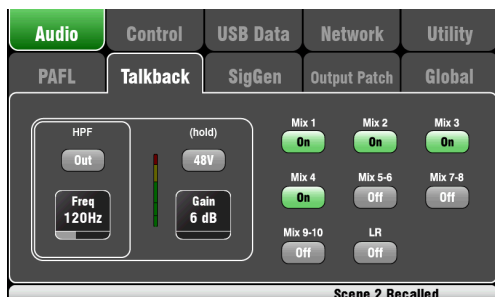

Set up and assign Talkback to talk to the musicians via their monitors, or make announcements via the house (PA) mix:

HPF – Dial in the High Pass Filter to remove low frequency pops and resonance while talking.

48V – Hold for 1 second to switch on phantom power.

Gain – Adjust the talkback mic level.

Assign – Touch to toggle the assignments to the LR and Mixes 1-10 on or off.

Press the surface **Talk** key to talk to the musicians or house.

7.3 Audio Setup –Signal Generator

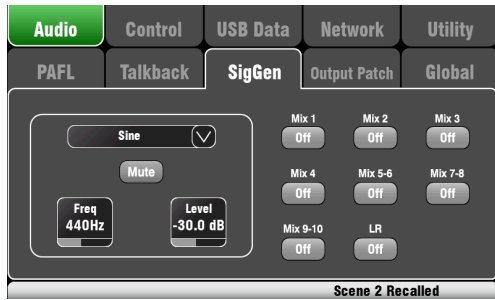

Set up and assign the Signal Generator to test loudspeakers and align levels between equipment.

Source – Touch to open the list of sources available:

- Sine – Pure tone with adjustable frequency. Set to 1kHz and use meters to match equipment levels.
- White Noise – Equal energy per Hz.
- Pink Noise – Filtered white noise for equal energy per octave. This is a good source to use for testing loudspeaker drivers and phase. Its response matches the way we hear frequencies.
- Band-pass Noise – Pink noise filtered around a frequency which can be swept from low to high.

Level – Start with the level set low to avoid unexpected loud sounds when you assign to the mixes.

Mute – Turns the signal off.

Assign – Touch to toggle the assignments to the LR and Mixes 1-10 on or off.

Note – To avoid noise in the system remember to turn the assignments off when you are finished using the generator.

7.4 Audio Setup – Output Patch

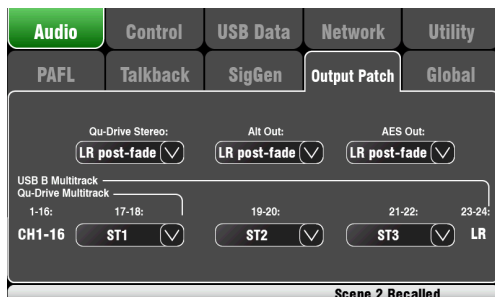

Use this screen to patch signals to the outputs. Touch a box to open up the list of available options. Changes are applied instantly.

Qu-Drive Stereo – Choose the source for the top panel Qu-Drive stereo recording. Use the LR main mix if you want to record your desk mix.

Alt Out – Choose the source for the rear panel stereo Alt Out jacks.

AES Out – Choose the source for the rear panel AES digital output.

Multitrack – This section shows the sources for the top panel Qu-Drive multitrack recording and rear panel USB B streaming. They share the same sources. Tracks 1-16 are permanently sourced from CH1-16 post-preamp Insert sends. Qu-Drive is 18-tracks with one patchable stereo pair for track 17-18. USB B is 24 channel with three patchable stereo pairs including the same track 17-18 as Qu-Drive and the LR post-fade mix on track 23-24.

7.5 Audio Setup - Global

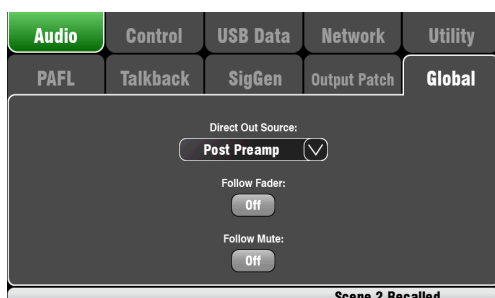

This screen presents the setting for all channel Direct Outputs. These outputs can be patched to the internal FX for single channel system effects.

Source – Choose the point in the channel signal path that feeds the direct output. Touch the buttons for **Follow Fader** (post-fade) and **Follow Mute**.

Set this Post-Delay (post all processing) for FX sends.

7.6 Control Setup - SoftKeys

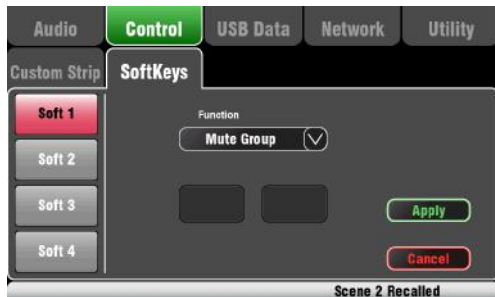

Qu features 4 SoftKeys. These are called 'Soft' because their function can be freely assigned by the user.

Function – Touch the box to open and choose from the list of available functions. Touch **Apply** to confirm the changes.

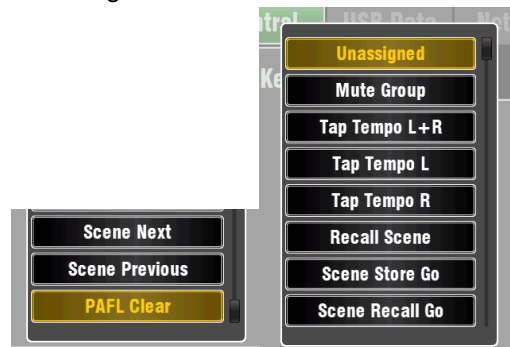

7.7 USB Data

Note – First release firmware V1.0 does not support the archiving of the Qu configuration and Scenes to USB key.

Please check the Allen & Heath web site for the latest firmware and information on the Qu mixer.

7.8 Network Setup

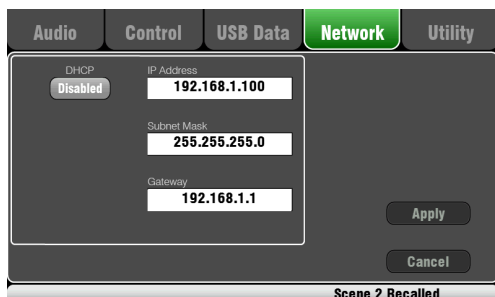

Use this screen to set the TCP/IP address for the Network port. It is important that this address is compatible with the addresses of equipment connected to the port, for example a laptop providing MIDI control of mixer parameters, or a wireless router providing remote control using the Qu-Pad iPad app.

Typical setting is to enable DHCP as most wireless routers will be set to allocate an IP address to the mixer automatically.

Note – First release firmware V1.0 does not support the Qu-Pad iPad app.

7.9 Utility - Calibration

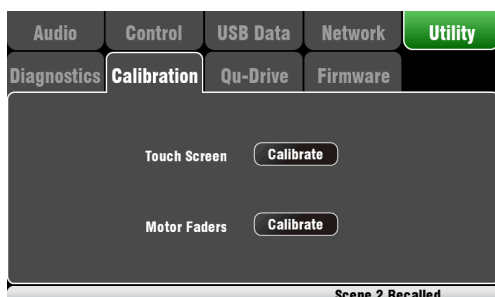

Use the routines here to calibrate the touch accuracy of the **Touch Screen** and positional accuracy of the **Motor Faders**.

Follow the on-screen instructions.

7.10 Utility – Qu-Drive

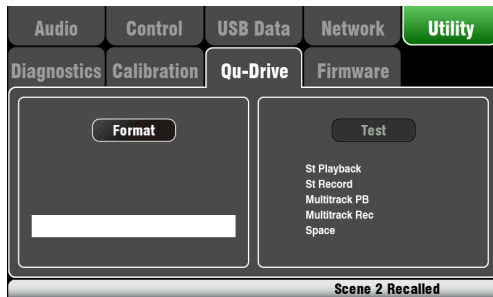

This screen provides utilities to test and format the USB key or hard drive used in the top panel Qu-Drive socket.

Plug in the USB key or drive. Wait for the mixer to read the drive. If it is recognised then the **Format** button will be enabled. Use this to format the drive ready to handle the Qu audio recording and data. Once formatted you do not need to format it again.

Note – Formatting the drive will erase all current data on it. If you want to keep this then make sure you archive the data elsewhere first.

Note – For reliable performance we recommend you always format your USB key or hard drive for use with the Qu mixer. Use this with Qu only. Do not use the key for other applications.

7.11 Utility – Firmware Update



The Qu mixer operating firmware can be easily updated using a USB key.

- Download the latest version of Qu firmware from the Allen & Heath web site.
- Read the Release Notes provided with the firmware.
- Use the **Setup / Utility / Qu-Drive** screen to format a USB key before using it with the mixer.
Note - This will delete all existing data on the key.
- It is important to remove any previous versions of Qu firmware from the USB key.
- Copy the latest firmware file to the root directory of the USB key.
- Plug the USB key into the Qu-Drive port. Select the **Setup / Utility / Firmware** screen and wait for the USB key to be read. If valid firmware is found its version number will be displayed.
- Touch **Update** to update the Qu mixer to this version of firmware. The surface Pan control indicators flash in sequence while the update is running.

8. Resetting the Mixer

There are two ways to reset the Qu settings:

8.1 Reset Mix Settings – A starting point for mixing



Reset mix settings:

- Source Preamp, Gain 28dB, 48V off
- ST1-3 trim 0dB
- HPF out, 100Hz
- PEQ and GEQ in, flat
- Gates out, thres -36dB, depth 20dB
- Comp out, thres 0dB, ratio 3.2:1
- Delays 0ms
- Mix source post-EQ
- Sends to Mixes -Inf and pre-fade
- Sends to FX -Inf and post-fade
- Direct Out post-fade/mute, trim 0dB
- Mutes off
- Channel faders -Inf
- FX return faders 0dB
- FX send and Mix master faders -4dB
- LR master fader -Inf
- FX1 = Mix>Return, Reverb (EMT250)
- FX2 = Mix>Return, Delay (Vocal)
- FX 3 and 4 = unassigned
- Mute Groups unassigned
- AES, Alt Out patch LR post-fade
- Qu-Drive stereo patch LR post-fade
- USB patch CH1-16, ST1-3, LR
- Talkback unassigned, HPF 120Hz
- Custom Strip unassigned
- SoftKeys = Mute Groups 1-4

This button in the **Scenes** screen resets the mixer to a known starting point for mixing. It provides a quick way to reset the processing, mixes and patching before a show or after another user has finished with it.

All parameters that can be stored in Scene memories are reset to a factory default. Parameters that are not stored in scenes are not affected. This reset does not affect existing scenes stored in the mixer.

If you want to keep your current settings then save these as a Scene before resetting the mixer.

Touch and hold the **Reset Mix Settings** button for 1 second until the confirmation screen appears. The hold function prevents accidental operation during performance. Touch **Yes** to reset the mixer or **No** to exit without resetting.

This 'resets the board' ready for mixing:

- All preamps are patched and have nominal mic gain set and phantom power switched off, a good start for vocal microphones,
- All EQ is switched in and set flat ready to start adjusting tone,
- Gates and compressors are switched out but have their parameters set ready for being switched in for applications such as drum gating and vocal compression,
- Channels are assigned to the mixes and FX with their faders and send levels turned down ready to start dialling into the mix,
- The mixes are set pre-fade and sourced post-EQ, pre-compressor ready to be used as monitor sends, a common application for the mixes.
- The FX master and return faders are turned up and a default reverb and delay patched ready for you to hear the effects as soon as you raise a channel send.
- The Mix master faders are turned up ready to hear sound when you raise a channel send. The main LR master is turned down to avoid unexpected loud level in the PA.
- The output patching follows the main LR mix to suit the more common applications.

Creating your own start settings – You can start by resetting the mixer and then editing the patching, levels and parameters to suit your starting preferences. Name and store this as a **Scene**, for example Scene 1 "Reset Board". You could also copy this to another Scene as a backup.

8.2 System Hard Reset



Hold for 3 seconds while powering up the mixer



System hard reset:

- Source Preamp, Gain 28dB, 48V off
- ST1-3 trim 0dB
- HPF out, 100Hz
- PEQ and GEQ in, flat
- Gates out, thres -36dB, depth 20dB
- Comp out, thres 0dB, ratio 3.2:1
- Delays 0ms
- Mix source post-EQ
- Sends to Mixes -Inf and pre-fade
- Sends to FX -Inf and post-fade
- Direct Out post-fade/mute, trim 0dB
- Mutes off
- Channel faders -Inf
- FX return faders 0dB
- FX send and Mix master faders -4dB
- LR master fader -Inf
- FX1 = Mix>Return, Reverb (EMT250)
- FX2 = Mix>Return, Delay (Vocal)
- FX 3 and 4 = unassigned
- Mute Groups unassigned
- AES, Alt Out patch LR post-fade
- Qu-Drive stereo patch LR post-fade
- USB patch CH1-16, ST1-3, LR
- Talkback unassigned, HPF 120Hz
- Custom Strip unassigned
- SoftKeys = Mute Groups 1-4
- Input PAFL = PFL, mix = AFL
- PAFL additive mode off
- Sel follow PAFL on, LR to PAFL on
- PAFL trim 0dB, delay 0ms
- Talkback mic gain 27dB
- Sig Gen Pink Noise, unassigned
- Clears all scene Safes (**not in V1.0**)
- Clears all Scene memories
- Clears all User Libraries (**not in V1.0**)
- Resets Network address to DHCP
- Resets touch screen calibration

A power up reset is available if you need to fully reset the Qu mixer settings and memories. This could be done to clear the system out before sending the mixer to a client, or if you suspect a system problem.

To reset mix parameters before starting a show or sound check, use a Scene or the Reset Mix Setting function described earlier in this guide.

Note – A hard reset clears all current settings, all Scenes and all User Libraries.

First turn off the system including amplifiers and powered speakers.

To hard reset the Qu mixer - Press and hold the touch screen Reset and Setup keys together and then power up the mixer. Keep the keys pressed for at least 3 seconds while the mixer boots. Release the keys.

The hard reset:

- Resets the current settings as described for the Reset Mix Settings button,
- Resets non-scene parameters and user preferences to a factory default,
- Clears scene recall Safes,
- Clears all memories including Scenes and User Libraries
- Resets the Network IP address and the touch screen calibration

Note – Channel Safes, User Libraries and data transfer via USB key are not available in first release firmware V1.0

9. Specifications

Inputs	
XLR Mic/Line Inputs 1-16	Balanced, 48V phantom power
Mic/Line Preamp	Fully recallable
Input Sensitivity	-60 to +5dBu
Analogue Gain	-5 to +60dB, 1dB steps
Maximum Input Level	+19dBu
Input Impedance	>5kΩ
TRS jack Line inputs 1-16	Balanced
Input Sensitivity	-50 to +20dBu
Analogue Gain	-10 to +60dB, 1dB steps
Maximum Input Level	+29dBu
Input Impedance	>10kΩ
Stereo ST1, ST2 Line Inputs	Balanced, 1/4" TRS jack
Mono capability	L normals through R for Mono input
Input Sensitivity	Nominal +4dBu
Trim	+/-24dB
Maximum Input Level	+22dBu
Input Impedance	>7kΩ
Stereo ST3 Line Input	Unbalanced, 3.5mm Mini Jack
Input Sensitivity	Nominal 0dBu
Trim	+/-24dB
Maximum Input Level	+18dBu
Input Impedance	>7kΩ
Mic/Line Channel noise	20-20kHz, Direct Out
Mic EIN	-126 dB with 150Ω source
Unity gain 0dB	-92 dBu
Mid gain +30dB	-85 dBu
Mic/Line Channel THD+N	20-20kHz, Direct Out @0dBu 1kHz
Unity gain 0dB	0.0005 % -89 dBu
Low gain +10dB	0.001% -83dBu
Mid gain +30dB	0.001% -83dBu
Talkback Mic Input	Balanced, 48V phantom power
Input Sensitivity	-55 to +6dBu
Maximum Input Level	+10dBu
Input Impedance	>5kΩ

System	
Measured balanced XLR in to XLR out, 0dB gain, 0dBu input	
Dynamic Range	112 dB
System Signal to Noise	90 dB (@+4dBu, 22Hz - 22kHz)
Frequency Response	+0/-0.5dB 20Hz to 20kHz
Headroom	+18dB
Internal operating Level	0dBu
dBFS Alignment	+18dBu = 0dBFS (+22dBu at XLR output)
Meter Calibration	0dB meter = -18dBFS (+4dBu at XLR out)
Meter Peak indication	-3dBFS (+19dBu at XLR out), multi sensing
Meter Signal indication	-48dBFS (-26dBu at XLR out)
Main meter Type	12 LED, Fast (peak) response
Strip meter Type	3 LED, Fast (peak) response
Sampling Rate	48kHz +/-100PPM
ADC	24-bit Delta-Sigma
DAC	24-bit Delta-Sigma
Latency	1.2 ms (local XLR in to XLR out) 0.7 ms (local XLR in to AES out)
Operating Temperature Range	0 deg C to 35 deg C (32 deg F to 95 deg F)

Outputs	
Mix1-10 and LR Outputs	Balanced, XLR
Output Impedance	<75Ω
Nominal Output	+4dBu = 0dB meter reading
Maximum Output Level	+22dBu
Residual Output Noise	-90 dBu (muted, 20-20kHz)
Stereo Alt Output	Balanced, 1/4" TRS jack
Source	Patchable
Output Impedance	<75Ω
Nominal Output	+4dBu = 0dB meter reading
Maximum Output Level	+22dBu
Residual Output Noise	-92 dBu (mid level, source muted, 20-20kHz)
Stereo 2Trk Output	Balanced, 1/4" TRS jack
Source	LR post-fade
Output Impedance	<75Ω
Nominal Output	+4dBu = 0dB meter reading
Maximum Output Level	+22dBu
Residual Output Noise	-90 dBu (muted, 20-20kHz)
AES Digital Output	2 channel, XLR
Sampling rate	48kHz
Output	2.5Vpp balanced terminated 110Ω

USB Audio	
Qu-Drive Stereo	Q-Drive
Device	USB hard drive required for recording
Stereo Record	2 channel, WAV, 48kHz, 24-bit, patchable
Stereo Playback	2 channel, WAV, 44.1/48kHz, 16/24-bit, to ST3
Qu-Drive Multitrack	Q-Drive
Device	USB hard drive only
Multitrack Record	18 channel, WAV, 48kHz, 24-bit CH1-16 + patchable stereo pair
Multitrack Playback	18 channel, WAV, 48kHz, 24-bit CH1-16, ST1
USB B Streaming	USB 2.0 MAC compliant only
Send (upstream)	24 channel, WAV, 48kHz, 24-bit
Return (downstream)	22 channel, WAV, 48kHz, 24-bit
Mains Power	
Qu-16	100-240V AC, 50/60Hz, 82W max
Fuse rating	T1.6 AL 20mm
Dimensions and Weights	
Qu-16 Mixer	Width x Depth x Height
Desk mounted	440 x 500 x 186 mm (17.4" x 19.7" x 7.4")
Rack mounted	483 x 486 x 190 mm (19" x 19.1" x 7.5"), 11U
Packed in shipping box	610 x 680 x 380 mm (24" x 27" x 15")
Packed weight	13.5 kg (30 lbs)
Unpacked weight	10 kg (22 lbs)

9.1 System Block Diagram

Qu-16 SYSTEM BLOCK DIAGRAM

30 channel x 16 bus x 12 mix + 4FX DSP Engine

10/5/13

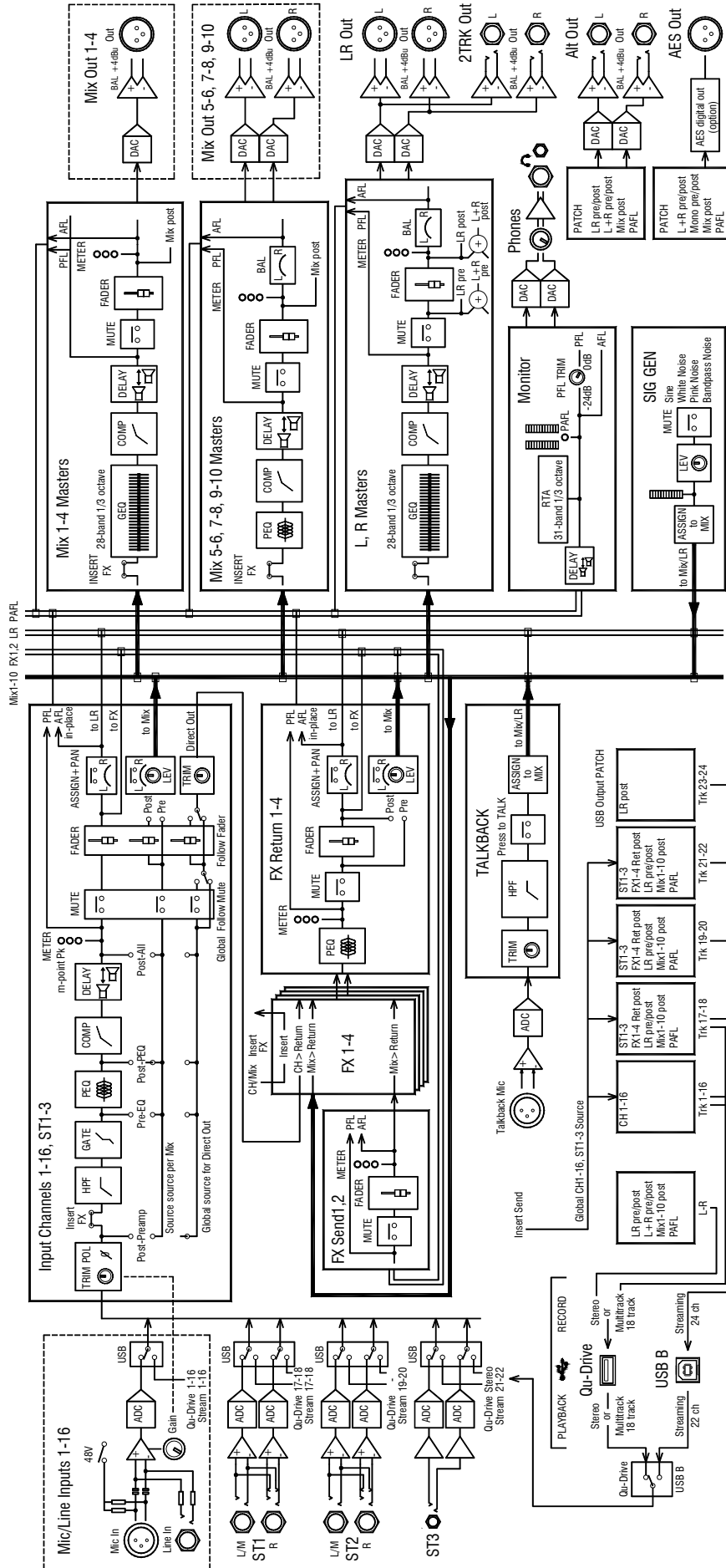

9.2 Mechanical Details

The following provides information for mixer installation. The Qu-16 can be operated on a flat surface, mounted in a 19" equipment rack or plinth, or fitted into a flightcase.

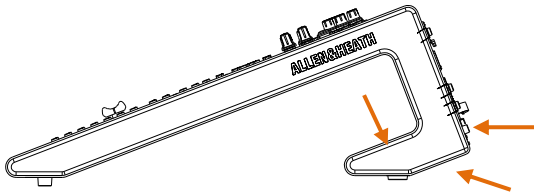

Ventilation - Make sure that air flow around the ventilation slots at the rear and underside of the mixer is not obstructed. Keep these areas clear when flight casing, installing or operating the mixer.

Note – Blocking or obstructing the ventilation slots may cause damage to the mixer through overheating.

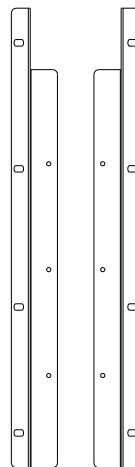
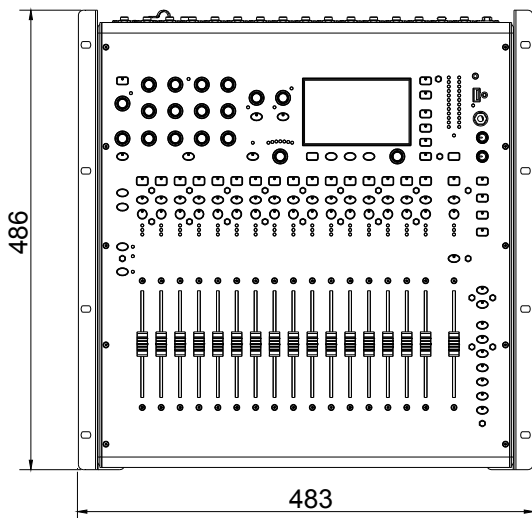
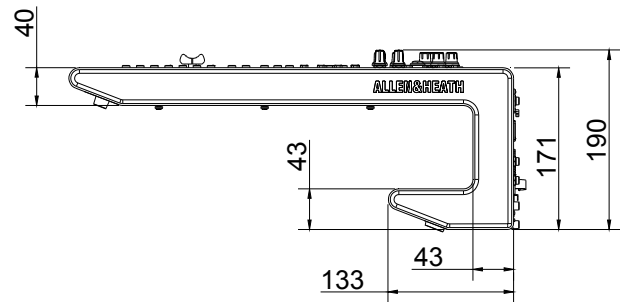
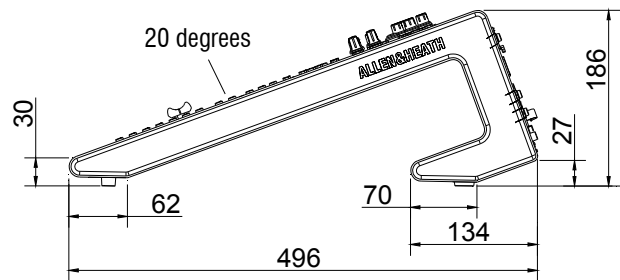
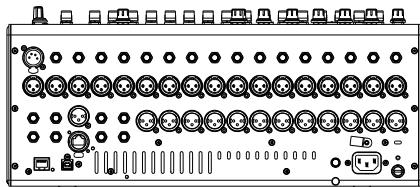
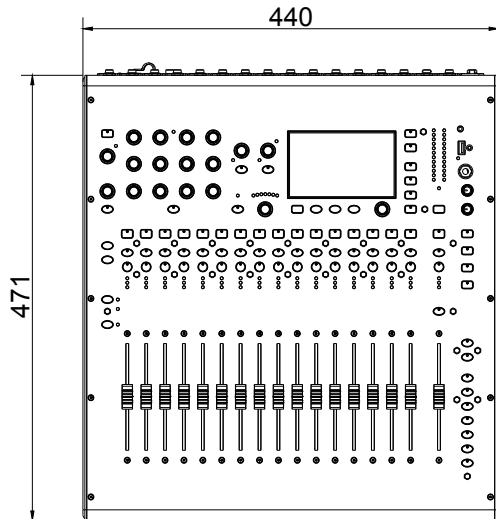

Rack Mount Option – A kit of parts is available from Allen & Heath to mount the Qu-16 in a standard 19" equipment case.

Rack kit part number **QU-16-RK19**

Minimum rack space required is **11U**.

Note - Allow space for the connectors and cables at the rear.

The rack ears can be fitted without the need to remove the plastic side trims. Simply secure them to the base of the mixer with the 6x M4x8 screws supplied (part number AB0332) using a T20 Torx screwdriver.

Secure the mixer in the 19" rack with 8x M6 screws with plastic cup washers to protect the mixer surface.

REGISTER YOUR PRODUCT

Register online at:

<http://www.allen-heath.com/uk/support/Pages/ProductRegistration.aspx>

Register by post using the PRODUCT REGISTRATION CARD on the rear cover to:

Allen & Heath Limited
Kernick Industrial Estate
Penryn
Cornwall
TR10 9LU
England



Technical Support

At Allen and Heath, we are committed to providing you with the best technical support before, during and after the purchase of your mixer. By registering your details with us and becoming a Registered User, you will ensure that any warranty claim you might make will be actioned quickly and with the minimum delay. By completing the questionnaire on the form, you will also help us to understand your future needs, so that we can make the mixers you want. We'd also like to know what you think of us and our dealers, and our service to you. Please give us as much detail as possible, we really want to know what you think!

Product News

By registering your new product with us and giving us your email or address details, you will ensure that you will hear about new products as soon as they are launched. We would also like to contact you from time to time to ask you your thoughts on current and potential products - we value input from the most important part of our supply chain - our customers!

Website

Allen and Heath's website is packed full of information and news about our products, their applications, news items, how to contact us, brochures, user manuals and more. The site is kept up to date and is regularly refreshed, so it's worth coming back to, time and time again. Simply visit www.allen-heath.com to see what's new and to be able to contact the key people in Allen and Heath.

SERIAL NUMBER	
---------------	--

ALLEN&HEATH

ALLEN & HEATH LIMITED
Kernick Industrial Estate
Penryn
Cornwall
TR10 9LU
England

Affix
Stamp

ALLEN & HEATH PRODUCT REGISTRATION

Thank you for buying an Allen & Heath product. We hope that you're happy with it and that you enjoy many years of faithful service with it.

SERIAL NUMBER

Please return this section of the card by mail and retain the other part for your records. Alternatively, you can register online at www.allen-heath.com
Thanks for your help.

Your name

Company name:

Address1

Address2

Town/City

County/State

Country

Postcode/Zip

Telephone

Email

Why did you choose this console?

Which other products did you consider before choosing A&H?

What will you use this product for?

Is there anything you would like to improve on this mixer?

What audio magazines do you read?

If you were going to design a mixer for your work, what are the 6 most important features it should have (in order of importance)

1 _____ 2 _____

3 _____ 4 _____

5 _____ 6 _____

We may use the information you provide to inform you of future product developments. We will not give or sell this data to third parties. Please indicate with an 'X' if you do not wish to receive any further communications from us.