

Australian Monitor

PA800
&
PA1200

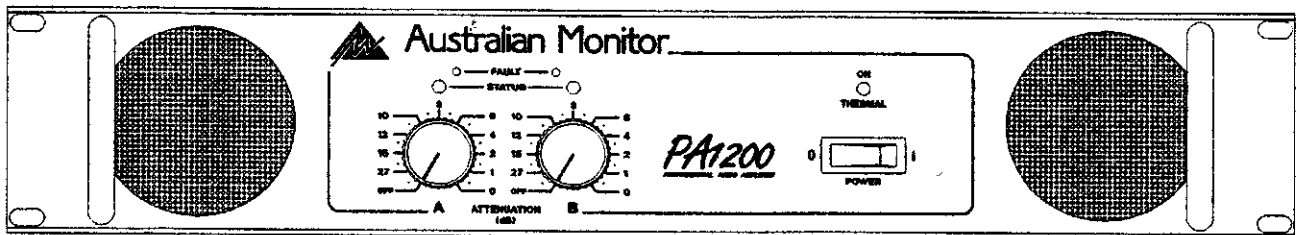

Operation Manual

IMPORTANT!

Please read carefully.

This operation manual contains important information regarding safety precautions, installation, performance, operation and maintenance of your *PA* Series power amplifier. You should familiarize yourself with the contents of this manual **before** operating your amplifier.

Safety Precautions and Labelling

The rear panel of the unit has a number of markings and internationally recognized symbols related to the hazards and precautions that should be taken when operating MAINS connected equipment.

The presence of a LIGHTNING FLASH with an arrowhead contained within the boundaries of an equilateral triangle is intended to alert the user that dangerous uninsulated voltages may exist within the units enclosure. These voltages may be of a sufficient magnitude as to constitute the risk of an electrical shock.

This symbol is reinforced with the text:

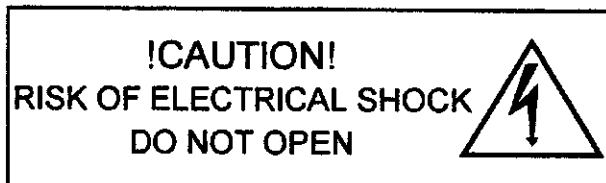

The presence of an EXCLAMATION MARK contained within the boundaries of an equilateral triangle is intended to alert the user that there is important operating and maintenance literature that accompanies the unit.

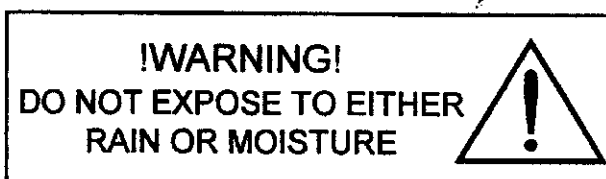

The unit should not be operated in a situation where it may encounter the entry of water, rain, or any fluids. To expose the unit to the above conditions may make the operation of the unit hazardous and increase the risk of electrical shock.

**REFER SERVICING TO
QUALIFIED PERSONNEL.
NO USER SERVICEABLE
PARTS INSIDE.**

The user should not attempt to service the unit. Only qualified and knowledgeable personnel familiar with the internal workings of the unit should attempt any repair, servicing or authorized modification to the unit. The unit does not contain any parts which the user can service or re-use in this or any other product.

If you are in need of special assistance and the information you require is outside the scope of this manual, please contact your nearest service agent or Australian Monitor direct:

**THE TECHNICAL MANAGER
AUDIO TELEX COMMUNICATIONS PTY LTD,
PRIVATE BAG 149,
SILVERWATER, N.S.W. 2128
AUSTRALIA.**

	Phone	Fax
Local	(02) 9647 1411	(02) 9648 3698
International	(612) 9647 1411	(612) 9648 3698
Email	ho@audiotellex.com	



Contents

	Page
1. Introduction	5
2. Controls, Connectors and Indicators	6
2.1 Front Panel	7
2.2 Rear Panel	9
3. Installation	11
4. Operation	13
5. Bridge Mode	15
6. Two Ohm or Not Two Ohm	16
7. Maintenance	17
8. Warranty	18
9. Specification	19

List of Illustrations

	Page
Figure 1. Block Diagram	5
Figure 2. Front Panel Layout	6
Figure 3. Rear Panel Layout	8
Figure 4. Case Dimensions	10
Figure 5. "Speakon" Connector Wiring	12
Figure 6. Bridge Mode Speaker Wiring	15



Features:

- Custom designed, 2RU heavy duty alloy chassis.
- Open modular construction for ease of servicing.
- Symmetrical layout - even weight distribution.
- Well-regulating, high current power supply.
- High efficiency toroidal mains transformer.
- Binding post and Neutrik "Speakon" output connection.
- Stereo or bridged / mono operation.
- Input signal strapping (loop through) connectors.
- 21 Position detented attenuators.
- Balanced inputs and buffered attenuators.
- 1 Watt output indication (2.828 volts).
- 1 dB below output clip indication.
- Massive heat-sink / heat-exchangers.
- Efficient front to back cooling.
- Dual, twin speed axial fans.
- Multi-role output fault indication.
- Front carry handles. Rear rack mount ears.
- Plug in signal modifiers (optional).
- Signal ground lift switch.
- High-quality, close-tolerance components throughout.

Protection Features

- Suppression of inrush current at mains turn-on.
- Input muting at turn-on.
- Input overvoltage protection.
- Radio-frequency interference suppression.
- Short-circuit protection and indication.
- High overload mains fuse.
- Internal, independent DC supply rail fuses.
- Layout, grounding, decoupling and componentry have been optimized to provide the user with **stability, reliability and longevity.**



1. Introduction

Congratulations on choosing Australian Monitor for your professional amplification requirements.

The design of your *PA-Series* Audio Power Amplifiers embrace all the aspects of a well designed unit. The visual design, mechanical, electrical and sonic parameters, along with our dedicated manufacturing process, have all been optimized to provide a professional tool that exhibits quality, reliability and longevity.

The *PA-Series* amplifiers are 2 unit (3.5") tall, 19" wide rack mountable units.

Each channel of the amplifier comprises a balanced active input with a buffered attenuator driving a differential class A drive stage which in turn drives a fan-cooled, class AB, MOSFET output stage configured as a source follower. The unit operates from a high current-capable linear power supply.

These units have been specifically designed to deliver their high power output with minimal distortion, and provide the critical degree of control required by your speakers, at high duty cycles for extended periods.

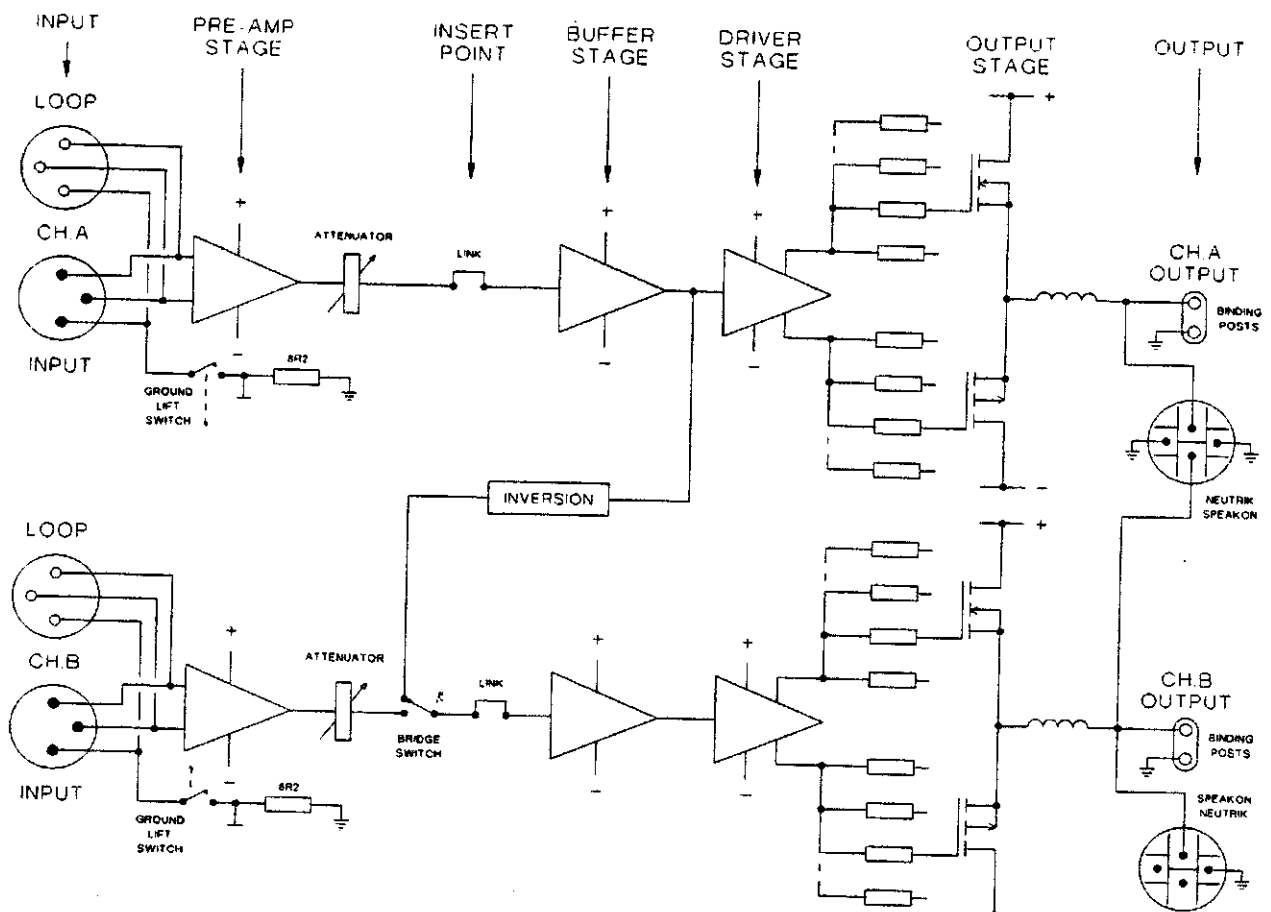

Figure 1 Amplifier Block Diagram

2. Controls, Connectors & Indicators

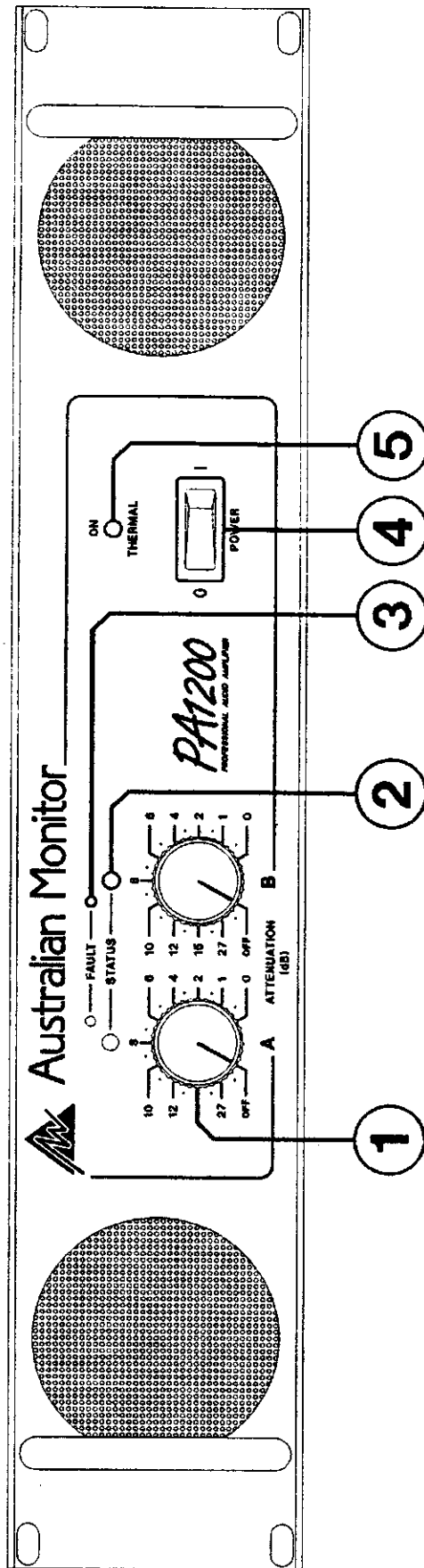

Figure 2 Front Panel Layout



Front Panel

The *PA* Series models have identical front panel layouts.

Figure 1 shows the panel layout of the *PA* Series. The functions of the controls and indicators are as follows:

1 Attenuator

Level control for your amplifier is provided by a 21 position detented potentiometer and indicates gain reduction in decibels from the 0 dB position (maximum gain, no attenuation).

2 Status Indicator

This is a dual color LED which displays the status of the output stage and displays three levels of operation.

These levels are:

Below 1 watt	(unlit)
1 watt and above	(green)
1dB below actual clipping	(red)

The LED will turn green once the output voltage exceeds 2.828 volts (1 watt re 8 ohms or 2 watts re 4 ohms). This is equivalent to:
24dB below rated power for a PA800 or
26dB below rated power for a PA1200.

The LED will change to red once the output exceeds the -1dB point before actual clipping of the amplifier's output stage. The threshold of the -1dB point is referred to the amplifier supply rails and alters with changes in the mains supply, changes in the load and duty cycle fluctuations.

The attack and decay time (ballistics), of the status circuit are those of a Peak Programme Meter (P.P.M.)

If using this indicator to line up sensitivities, apply a steady state tone (e.g. slate on a mixing console). The 1 watt level is the mid-point between the indicator illuminating and extinguishing green.

NOTE: The amplifier is not damaged by running into clipping, but speakers may be. To maximise the life of your speakers, try to keep clipping infrequent.

3 Fault Indicator

This amber LED will flash when a fault condition exists.

The fault detection circuit monitors the difference between drive and output in your amplifier.

If you have a short on the speaker output (or a blown negative rail fuse) the LED will flash brightly in sync with the programme. This LED will also flash with programme peaks for gross overloads or if the load is 2 ohms or less.

The circuit has two stages of operation:

1. It will provide indication (e.g. gross overload) but does not affect the input signal (a faint flash).
2. It will indicate and mute the input signal (e.g. shorted output) (brightly flashing or permanently on).

4 Power Switch

Press the switch to the **right** for power on (1) and to the **left** for power off (0). At start-up (turn-on) the input to the amplifier is muted by 30dB for approximately two seconds.

5 On/Thermal Indicator

This is a dual colored LED which will normally be **green** and indicates that the amplifier is on and receiving mains power.

In the advent of a thermal overload this LED will turn **red** indicating that the internal operating temperature of one or both amplifier channels has exceeded a safe level of operation and the channels will be automatically muted. The fans will continue to run and once the effected channel/s have had a cool-down period, they will un-mute and return to normal operation.

NOTE: You should always ensure that the fan grille is kept clean and free from the build up of dust and lint. This will ensure longer operation of your amplifier and reduce the possibility of it prematurely going into thermal shutdown mode.



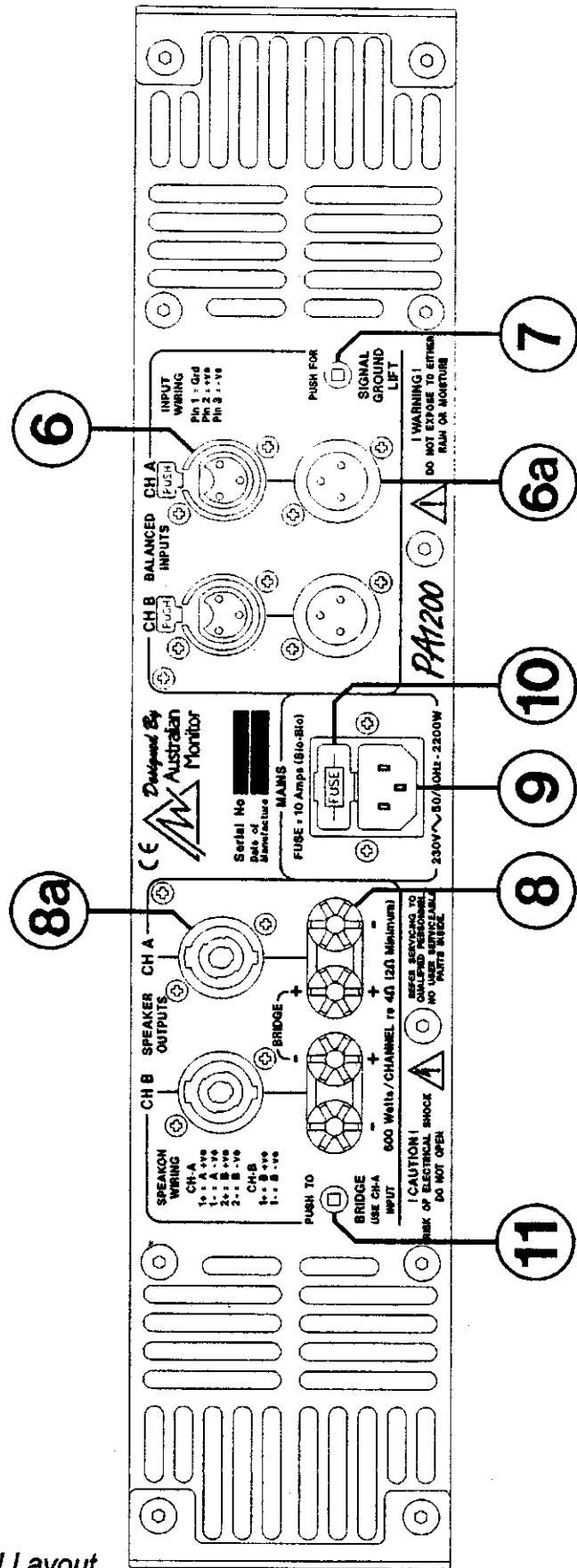

Figure 3 Rear Panel Layout



Rear Panel

6 Balanced Input

A female 3-pin XL type connector is provided on each input:

- Pin 1 = Signal Ground;
- Pin 2 = Hot (non-inverting or in phase);
- Pin 3 = Cold (inverting or reverse phase).

6a Signal Strapping

A male 3-pin XL type connector is provided and wired in parallel with the female input XLR for strapping / looping signal between amplifiers.

7 Signal Ground Lift Switch

When this switch is engaged it disconnects signal ground from the input connectors on both channels. It is intended to be used when "hum" is caused by earth loops (due to different ground potentials between source equipment and the amplifier) or stray magnetic field pick up on the input ground/shield wiring. (It does not interrupt signal ground continuity on the strapping connector). **The amplifier should be turned off before engaging this switch!**

8 Binding Post Outputs

Touch proof binding posts (banana jacks) are provided for speaker output termination with banana plugs or bare wire. The red post is used as **positive** and the black post is used as **negative**.

8a SPEAKON Output Connector

The NEUTRIK (NL4MP) 4way SPEAKON connector is provided as an additional speaker output. This emerging standard of loudspeaker to amplifier connection allows access to both channels of the amplifier via the one connector for bi-amp applications. Channel-A is considered the dominant channel and has both channels wired to the Speakon connector. See the installation section of this manual for detailed information on Speakon wiring.

9 Mains Connection

Your amplifier is fitted with an internationally recognised IEC mains inlet connector.

Please ensure that the connecting mains lead for use with this connector is of an approved type and is of sufficient current carrying ability.

Your *PA800* and *PA1200* require a minimum mains lead rating of 10 amps when operated from a 220

to 240 volt mains supply.

NOTE: Your unit must always be earthed!

10 Mains Fuse

A 20mm x 5mm fuse drawer is provided within the housing of the IEC mains connector. When you receive your amplifier it will have a working fuse and a spare fuse inside the fuse drawer. The drawer can only be opened once the mains lead is removed from the connector. The fuse is provided to protect both the mains and your amplifier as well as reducing the degree of damage if an internal fault exists.

When replacing the fuse, replace with an anti-surge (slow blow) type of the current rating indicated on the back panel above the fuse holder. Warranty does not cover a blown fuse or any resulting damage due to an incorrect fuse rating or type.

The *PA800* requires a 8 Amp Anti-Surge fuse.

The *PA1200* requires a 10 Amp Anti-Surge fuse.

11 Bridge Switch

Pushing this switch in engages the BRIDGED/ MONO mode of operation. In this mode your amplifier will only accept signal applied to channel A's input XLRs and the level of both channels will be controlled by channel A's attenuator. The output from channel B will automatically be of the opposite polarity (reversed phase) and speaker termination should be sourced from the red binding-post outputs.

D.C. Rail Fuses (Internally fitted)

Removing the bottom lid will show PCB mounted fuse holders holding the rail fuse for each supply to each channel. These 3AG "fast blow" type fuses are in series with the positive and negative supply rails for each channel of your amplifier's output stage. These fuses provide overall protection of the output stage and can also be used to isolate individual channels in case a fault condition exists.

If you need to replace the rail fuses they must be replaced with the same type and current rating:

PA800 = 8 Amp.

PA1200 = 10 Amp.

NOTE: Replacement of the fuses should only be carried out by a competent and experienced person.



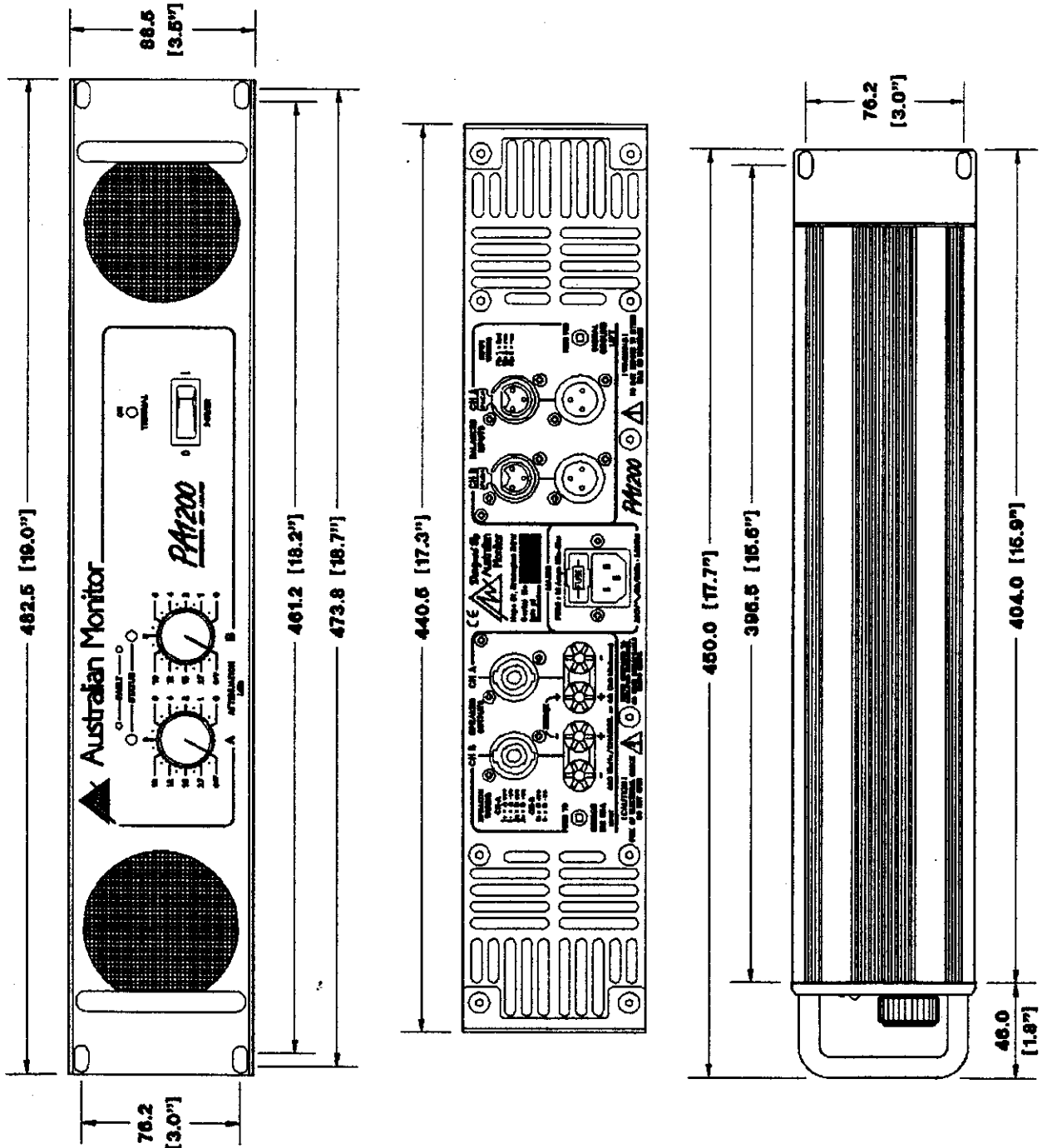

Figure 4 Dimensions



3. Installation

Power Requirements

Model: *PA800*
 Mains Voltage 240, 220-230 Fuse Rating 8 Amps

Power consumption at idle = 120 Watts.
 Power consumption at rated power = 1450 Watts.

Model: *PA1200*
 Mains Voltage 240, 220-230 Fuse Rating 10 Amps

Power consumption at idle = 160 Watts.
 Power consumption at rated power = 2200 Watts.

Ensure that **your** mains voltage is the same as the rear panel mains voltage marker (+/- 10%).

Mounting

Your amplifier is designed for standard 19" rack mounting and occupies 2 EIA rack units (3.5"). The mounting centers are:

Vertical: 3.0" (76.2mm)
 Horizontal: 18.2" (461.2mm) to 18.7" (473.8mm).

The slots in the mounting flange will accept bolt diameters up to 1/4" (6.35mm).

We recommend that you provide additional support for the amplifier, especially if road use is planned, as the weight can bend some racks otherwise. This support can be provided by secure shelving, support rails or a rear rack mounting strip to match up with the rear rack mount ears provided on your *PA* Series amplifier.

Cooling

Each channel of your *PA800/PA1200* amplifier is cooled by an axial fan which draws cool air from the front of the unit and expels the heated air from the rear of the unit. These units offer two speed fans which run at half speed, switching to full speed when the internal heatsink temperature exceeds 60°C (128°F).

An unrestricted airflow into and out from the unit must be provided. Any restriction of the air flow will cause

heat to build up within the unit and possibly force the unit into its thermal shutdown mode.

If the units are to be operated in an environment where the airflow is restricted such as sealed racks or even when running 2 ohm loads, the cooling should be supplemented by extra cooling fans to evacuate the heated air and aid the flow of cool air through the unit.

Input Wiring

IMPORTANT

Do not directly connect pin 1 on the amplifier's input or strapping XLR, to the amplifier's chassis, speaker ground or power ground!

NOTE

Input signal ground is not to be used as a safety ground (earth).

The input to your amplifier is a balanced 3-pin system and requires all three pins to be connected. Only high quality twin-core shielded cable should be used.

When wiring for a balanced source the connector going to the input of your amplifier should be wired as follows:

Pin 2 = HOT (In Phase - non inverting).
 Pin 3 = COLD (Reverse Phase - inverting).
 Pin 1 = GROUND / SHIELD.

When wiring from an unbalanced source you must ensure that pin 3 is connected to pin 1 (input ground), either by linking the pins in the input connector or by the source equipment's output wiring.

When wiring for an unbalanced source:

Pin 2 = Hot (in phase with the amplifier's output),
 Pin 3 = Ground/Shield (joins to pin 1).
 Pin 1 = Ground/Shield

NOTE:

In-line XLR connectors often have a termination lug that connects directly to the chassis of the connector. Do **not** link this lug to pin 1 at the amplifier's input as it will defeat the amplifier's input grounding scheme. This lug is often referred to as a "drain" and is used to provide a termination to the chassis for shielding purposes when a floating signal ground is required between the source and destination, or when disconnecting the signal ground is required to reduce earth loop noise, or noise induced into signal grounds from stray magnetic fields.



Output Wiring

When wiring to your speakers always use the largest gauge wire your connector will accept. The longer the speaker lead the greater the losses will be, resulting in reduced power and less damping at the load. We recommend using a heavy duty two core flex (four core flex if bi-amping) 10 to 12 gauge (2mm² to 2.5mm² or 50/0.25 or equivalent) as a minimum.

Binding Post Outputs

When terminating to the 4 mm binding post (banana jack) output connectors, banana plugs or bare wires can be used. The red terminal is **positive** and the black terminal is **negative** (ground).

If running in BRIDGE mode, only the red binding posts are used. Channel A provides the positive output to the load and channel B provides the negative output to the load.

SPEAKON Outputs

When using the NEUTRIK SPEAKON (NL4MP) connector for speaker output, use only the mating NEUTRIK NL4FC in-line connector. This connector is designed so that both channels can be fed from a single connector.

Two SPEAKON connectors are provided on the amplifier.

The "Channel A" SPEAKON actually carries both channel A & channel B outputs (see Figure 5: Speakon Connector Wiring Diagrams).

The "Channel B" SPEAKON carries the Channel B output only.

This arrangement allows you the option of connecting to the outputs separately or together. Connecting through a single connector has the advantage of minimising connections, preserving phasing and simplified channel allocation, which is particularly important when bi-amping or in bridge mode.

IMPORTANT

Do not overload your amplifier by connecting the channel B output twice!

Channel A is used as the "dominant" channel and when sourcing a dual output from Channel A the following standard should be used:

Channel A = Left or Low Frequencies.

Channel B = Right or High Frequencies.

When in **bridge** mode:

Pin 1+ = Bridge Output Positive

Pin 2+ = Bridge Output Negative.

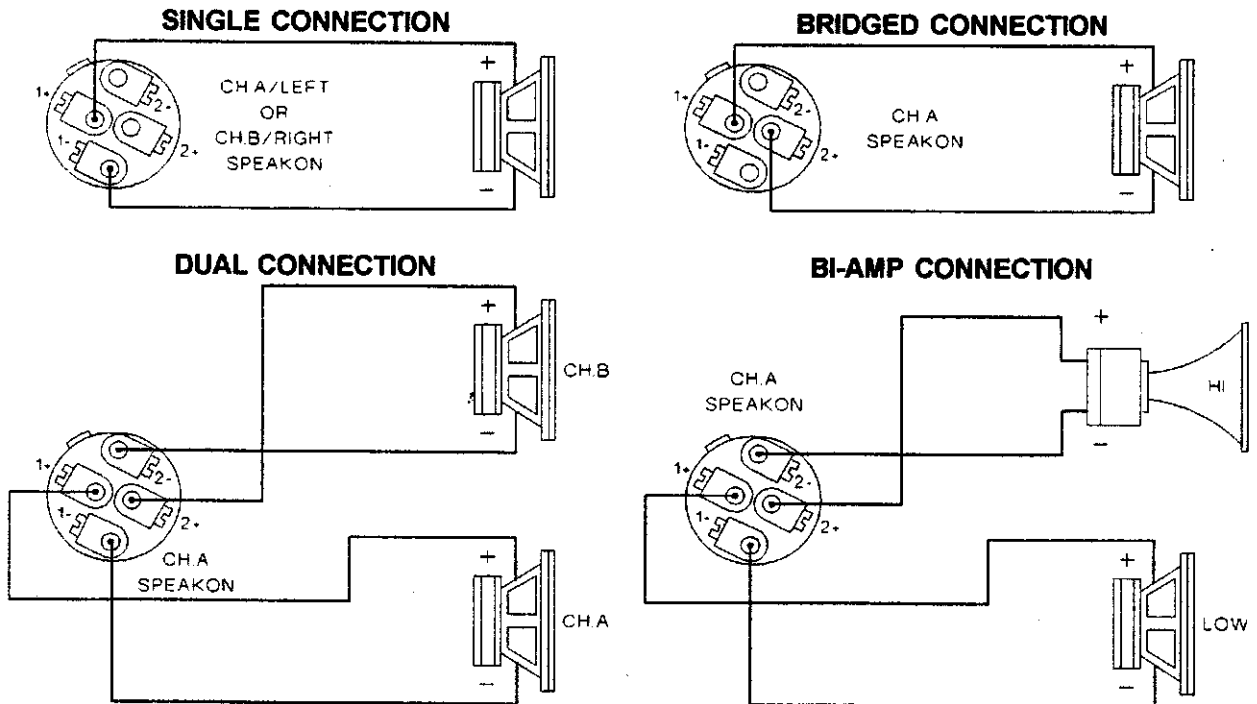

Figure 5. "Speakon" Connector Wiring Diagram



4. Operation

IMPORTANT

All signal source equipment should be adequately earthed. This not only ensures your safety but everybody else's as well. Faults can and do occur in mains connected equipment where the chassis can become "live" if it is not properly earthed. In these instances the fault in a "floating" (ungrounded) piece of equipment will look for the shortest path to ground which could possibly be your amplifier's input. If the fault current is large enough it will destroy the input to your amplifier and look for the next available path, which may be you!

Before making any connections to your PA800/PA1200 amplifier observe the following:

1. Ensure the mains voltage supply matches the label on the rear panel of your amplifier (+/- 10%).
2. Ensure that the power switch is OFF (to the left - 0)
3. Ensure that all system grounds (earth) are connected from a common point. Avoid powering equipment within a system from multiple power sources that may be separated by large distances.
4. Check the continuity of all interconnecting leads to your amplifier, ensure that there are no open or short circuited conductors.
5. Ensure that the power handling of your load (speakers) can adequately cope with the power output of the amplifier.

Before operating your PA800/PA1200 amplifier, ensure that:

- The attenuators are at the "OFF" position (fully anticlockwise).
- The GROUND LIFT Switch is not engaged (should be in the "out" position).
- The BRIDGE Switch is not engaged if you are not running the amp in bridged mode.

Powering Up

REMEMBER

The amplifier should be the last piece of equipment that you turn on and the first piece of equipment that you turn off.

We recommend turning the attenuators on your amplifier down when turning the unit on.

When you power up your PA800/PA1200, your amplifier goes through an establishment period before it will

accept signal. The Inrush Current Suppression (ICS) circuit is in operation for the first 0.5 seconds. This limits the mains current to prevent "nuisance-tripping" of circuit breakers.

During this period the THERMAL/ON LED will flash red whilst the mains voltage gradually charges up the power supply. You will then hear a relay "click", indicating mains is now directly applied to the amplifier and the THERMAL/ON LED will be green.

While the ICS circuit operates there is also a 30dB mute on the signal input. After two seconds this mute will release, allowing any applied signal to pass unattenuated.

When switching the amplifier off, wait a couple of seconds before switching the unit on again. This allows the ICS circuit to reset.

Level Matching

The normal operating position for the attenuator is the "0 dB" position (fully clockwise, no attenuation). In this position the amplifier operates at full gain. Turning the attenuator back (anticlockwise) reduces the input sensitivity by the amount marked on the attenuator scale (dial).

NOTE:

If full power output is required you should operate your amplifier with the front panel attenuator above the -15dB position, otherwise clipping of the input circuitry and its resultant distortion will occur before full output power is achieved.

Sensitivity

Your amplifier is a linear device operating with a fixed input to output voltage gain (less attenuation). The maximum output voltage swing is determined by the applied mains voltage, load, load type and the duty cycle of the applied signal.

The voltage gain factor of your amplifier is:

37 (31.5 dB) for a PA800

45 (33.0 dB) for a PA1200

The input sensitivity for your PA800/PA1200 amplifier when the attenuator is at the "0" dB attenuation position (fully clockwise) is nominally:

+4.0dB (1.23 volts in) for rated power into a 8 ohm load.

+3.0dB (1.10 volts in) for rated power into a 4 ohm load.



Each channel of your *PA800/PA1200* amplifier has a nominal balanced **input impedance** of 30kOhms (@1kHz) and should not present a difficult load for any signal source.

Your signal source (i.e. the equipment feeding the amplifier) should have an **output impedance** of 600 Ohms or lower to avoid unwanted high frequency loss in the cabling.

Input overload occurs at +20.5dBu (8.25 volts). See the specification section for more detailed information.

Hum Problems

Most equipment is designed for minimum hum when used under ideal conditions. When connected to other equipment, and to safety earth in an electrically noisy environment however, problems will often occur.

The three "E"s of hum and hum related noise which can plague your audio system are:

- a) Electrostatic radiation,
- b) Electromagnetic radiation, and
- c) Earth loops

Electrostatic radiation capacitively couples to system elements causing an interference voltage that mainly affects higher impedance paths, such as amplifier inputs. The source is generally a nearby high voltage such as a mains lead or a speaker lead. The problem can usually be reduced by moving the offending lead away, or by providing additional electrostatic shielding (i.e. an earthed conductor which forms a barrier to the field).

Electromagnetic radiation induces interference currents into system elements that mainly effect lower impedance paths. Radio transmitters or stray magnetic fields from mains transformers are often the cause of this problem. It is generally more difficult to eliminate this kind of interference, but again, moving the source away or providing a magnetic shield (i.e. a steel shield) should help.

Earth loops can arise from the interfacing of the various pieces of equipment and their connections to safety earth.

This is by far the most common cause of hum, and it occurs when source equipment and the amplifier are plugged into different points along the safety earth where the safety earth wiring has a current flowing in it. The current flowing through the wire produces a voltage drop due to the wire's resistance. This voltage

difference between the amp earth and source equipment earth appears to the amplifier's input as a signal and is amplified as hum.

There are three things you can do to avoid earth loop problems:

1. Ensure your mains power for the audio system is "quiet" i.e. without equipment on it such as air-conditioning, refrigeration or lighting which may generate noise in the earth circuit.
2. Ensure all equipment within the system shares a common ground/ safety earth point. This will reduce the possibility of circulating earth currents as the equipment will be referenced to the same ground potential.
3. Ensure that balanced signal leads going to the amplifier are connected to earth at one end only.

Signal Ground-Lift Switch

When proper system hook-up has been carried out, you may still have some hum or hum related noise. This may be due to any of the previously mentioned gremlins.

Your *PA800/PA1200* amplifier has a "Signal Ground Lift" switch which disconnects the input ground wiring from the amplifier. A substantial drop in hum and or hum related noise can result from judicious use of this switch.

NOTE

If the input ground lift switch is used you must ensure adequate shielding of the input wiring. If the signal source equipment does not provide adequate shielding (i.e. a definitive connection to ground) you must disconnect the shield from the input connector's ground pin (Pin-1) and re-connect it to the "drain" contact on the input connector. This will ensure the shield on your input wiring actually goes to the amplifier chassis and subsequently to earth.

DO NOT CONNECT PIN-1 DIRECTLY TO THE DRAIN CONNECTION.

You will defeat the amplifiers internal grounding scheme and possibly cause instability to the amplifier.

Always ensure that your amplifier is **off** and the attenuators are **down** when you engage this switch. This switch should only be used when the amplifier is operated from a **balanced** signal source.

NOTE: Be wary of **quasi-balanced** outputs, these are often no more than floating **unbalanced** outputs.



5. Bridge Mode

The term BRIDGE is used when two independent amplifier channels are used to drive the same load. The load is in series (a bridge) between the two amplifier channels.

Channel A is used as the "dominant" channel and its output is in phase with the input signal, and channel B has its phase reversed so it is exactly 180° out of phase with the input signal.

As two amplifiers with a phase difference of 180° are now driving the load you will now have double the voltage into the load. This means you will now have four times the power into that load. The output can now be considered as an active balanced output.

A common use of an amplifier in BRIDGE mode is for driving 70 volt & 100 volt distribution lines. In BRIDGE mode, The PA1200 can produce over 100 volts with line impedances over 8 ohms whilst the PA800 can produce over 84 volts with line impedances over 8 ohms.

Equally the units can be used in bridge mode to provide the correct voltage/power requirements for an applicable load.

As shown in Figure 6, there are three steps in setting

up your PA800/PA1200 amplifier for running it in BRIDGE mode.

Whilst the amplifier is off,

1. Connect the signal source to the Channel-A female input XLR. The Channel-A attenuator becomes the level control for both channels.
2. Engage the "push to bridge" switch.
3. Connect your load between the red binding post output terminals, where the positive side of the load is connected to the channel A output (marked BRIDGE+) and the negative side of the load goes to the channel B output (marked BRIDGE-). There are no further connections required.

You can also source the output from the Channel-A SPEAKON output connector where Channel-A will be on the pin marked 1+ and Channel-B will be on the pin marked 2+.

NOTE: You should check after market manufactured Speakon interconnecting speaker leads before connecting them to your amplifier. Some leads are manufactured for specific purposes, or specific use, and may have pins shorted inside the connector. Any speakon lead with shorted pins will obviously short the output of your amplifier (either to ground, or output to output - be careful).

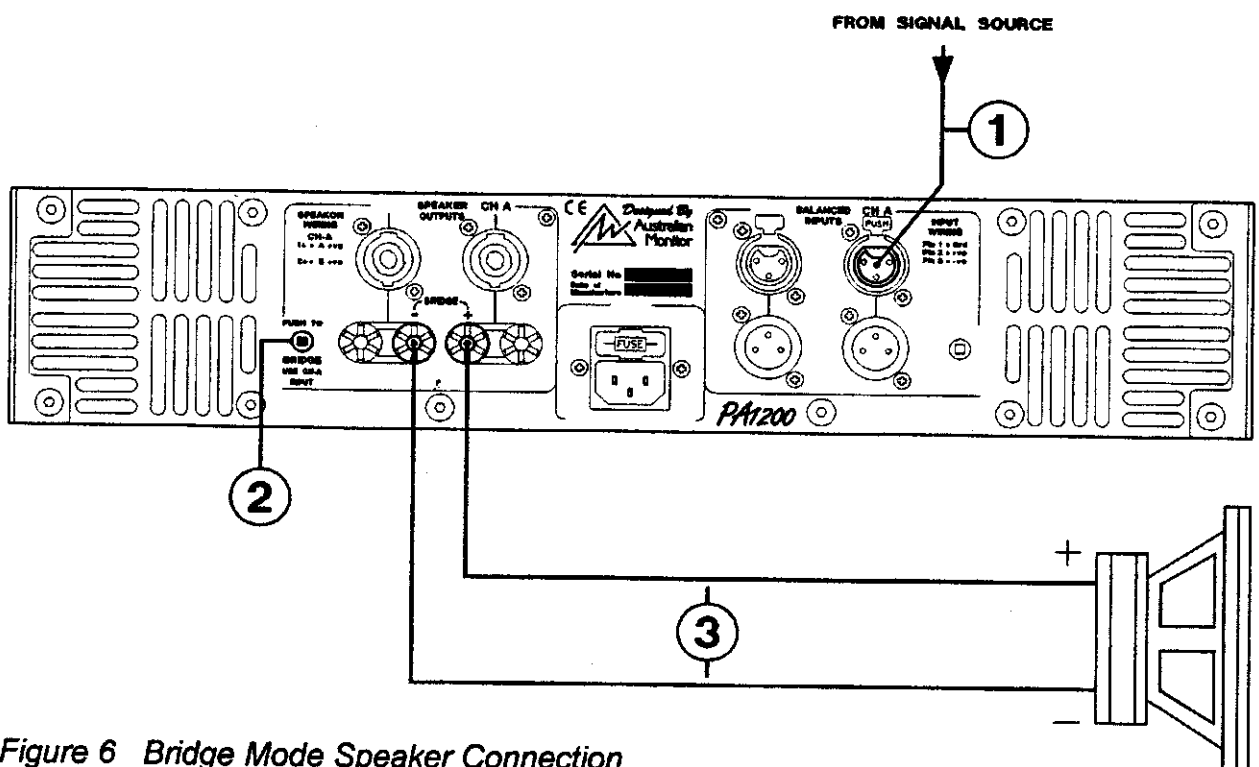

Figure 6 Bridge Mode Speaker Connection



6. Two Ohm or Not Two Ohm

NOTE:

Ensure adequate ventilation and monitor the FAULT indicators to guard against thermal shutdown when driving two ohm loads.

A Preamble.

The load that a loudspeaker presents to an amplifier is very complex and at different frequencies can be inductive, capacitive, resistive, or a combination of these (reactive). With the complex interaction of these attributes, which alter from loudspeaker to loudspeaker, a definitive load for an amplifier does not really exist.

Loudspeakers operating within an enclosure are specified with a **nominal** impedance. This nominal impedance is only a rough guide to the load it presents to an amplifier.

As an example, a loudspeaker with a nominal impedance of say 8 ohms, may have an impedance of over 50 ohms at resonance (bass frequencies), drop to less than 6 ohms after the resonance peak (through its mid band area) and then increase to over 16 ohms for higher frequencies.

A 4 ohm load makes an amplifier work "harder" than an 8 ohm load at the same voltage, as double the current is required.

Though various loudspeakers may be marked with the same nominal impedance, some loads are more difficult than others.

Bass frequencies usually exhibit higher impedances and require higher voltages to achieve the desired result. They also reflect higher energy back to the amplifier simply due to the amount of cone excursion involved at lower frequencies.

The **Mid** frequency band usually offers the lowest impedances and the highest duty cycles requiring both high voltage and high current.

The **High** frequency region usually offers a moderate impedance and usually does not need much voltage but the instantaneous current demand can be much greater than you think.

As well as this burden on the amplifier, the transient waveforms found in actual use can demand a lot more current than the "steady-state" sinewaves used in most amplifier bench tests.

The power output of your *PA800/PA1200* quoted on the

specification sheet is derived from a voltage excursion into a resistive load for a sine wave at a given frequency. Though this method is in line with the various standards that exist, it only gives an indication to the maximum voltage swing (before clipping) for a given load. This method of rating power does not give an indication of the current (Ampere) capability of the amplifier, nor does it show the amplifier's ability to sustain high energy waveforms.

Your *PA800/PA1200* amplifier is designed to be able to deliver more than twice the current than that shown on the specification sheet to cope with difficult loads and/or high energy waveforms.

This extra current reserve is the result of over engineering and is the headroom the amplifier utilizes to control the loudspeaker and deal with the "reactive energy" from the loudspeaker load that has to be dissipated within the amplifier.

Your *PA800/PA1200* amplifier is able to drive 2 ohm loads or operate in BRIDGE mode into 4 ohms. The operator must be aware that when driving 2 ohm loads or bridged 4 ohm loads that the currents running in the output stage are very large and will cause greater heat build up within the amplifier than higher impedance loads.

The **Front Panel FAULT** indicators can be used to provide an indication of the "difficulty" of the load and will give the operator an indication of the heat build up in the output stage.

If the fault indicators flash with the "clip" LED or do not illuminate until well into clipping then the load can be considered as normal or easy.

If the fault indicator starts to flash before the "clip" LED then the load should be considered complex and/or difficult.

For the more complex and/or difficult loads, the illumination of the "fault" LED on programme peaks should be interpreted as the **output level limit**. Driving the output continuously past this point could result in muting of the output stage, fuse's blowing or premature thermal shutdown.

The fault detection circuit is also thermally compensated, and fault indication will occur earlier when the unit is hot. If the "fault" LED continually lights earlier than normal, then the unit is heating up. If the signal level is not reduced to compensate for the heating of the unit then thermal shutdown may occur.



7. Maintenance

Your *PA800/PA1200* amplifier will need minimal maintenance. No internal adjustments need to be made to the unit to maintain optimum performance.

To provide years of unhindered operation we suggest a maintenance inspection be carried out on a regular basis, say every 12 months or so.

Fans

Due to the openness of the air path through your *PA800/PA1200* amplifier, very little dust should settle within the amplifier. The unit has been designed so that any dust and/or foreign particles that do settle within the amplifier will not unduly hinder the cooling of the unit.

The mesh grille in front of the fans will act to limit the amount of dust and lint entering the unit. You will find in time that there will be a build up of dust and lint on the grille which may start to hinder the airflow through the unit. You should periodically remove the dust and keep the grille clean. Removal of dust from the rear grille will also aid cooling.

Over time, dust may build up on the leading edge of the fan blades and reduce their cooling efficiency. The time taken for this to happen will depend on the environment and the amount of use.

The fan blades are accessible once the lids are removed and can be easily cleaned. You need only

hold the fan rotor still and wipe the dust off the blades. Many users **stall** the fan and use compressed air to blow the dust off the fan blades. It is important to note that the fan blades must be held still whilst blowing air over the blades otherwise you may burn out the bearings in the fan.

Fuses

Along with rear panel mains fuse, there is four (4) rail fuses provided internally in the unit. These rail fuses are in series with the positive and negative output supply to each amplifier channel and provide overall protection for the output stage. If the amplifier is subjected to heavy use such as short circuits, 2 ohm or bridged 4 ohm loads, these fuses will eventually fatigue and may require replacing to ensure they do not fail at an inconvenient time.

NOTE

Make sure the unit is **off** and is unplugged from the mains. Give the main filter capacitors time to discharge before removing lids and inspecting the fuses.

You should replace the fuse if the element is **sagging or discoloured**. Only ever replace with the same type fuse and current rating.

When checking for a failed fuse, do not rely on visual inspection alone. You should use an ohmmeter to check continuity.

Only **competent or qualified** persons should attempt any service or maintenance of your amplifier.



8. Warranty

Australian Monitor warrants the original purchaser of each PA-Series amplifier (purchased at an authorised Australian Monitor dealer) that it will be free from defects in materials and workmanship for a period of two (2) years from the original date of purchase.

Australian Monitor will, at its option, repair or replace any unit or component covered by this warranty which becomes defective or malfunctions under normal use and service during the period of this warranty, at no charge for parts or labour to the original owner.

This warranty does not cover blown fuses, faulty fuse contacts, thermal problems due to obstructed airflow, or defects or malfunctions resulting from accidents, misuse, abuse, operation with the incorrect AC mains voltage, connection to faulty equipment, modification or alteration without prior factory approval or service by unauthorised personnel.

It is the owner's responsibility to ensure that normal maintenance inspections are carried out at regular intervals as recommended in the maintenance section of this manual. Australian Monitor reserves the right to

refuse warranty service where the owner fails to take reasonable care in use and maintenance of the amplifier.

To validate this warranty, the original purchaser must complete and mail the warranty registration card directly to Australian Monitor within fourteen days of purchase.

To obtain warranty service, the equipment should be shipped to an authorised Australian Monitor dealer or to Australian Monitor at the owner's expense.

Units with a defaced serial number will not be accepted for warranty service. Any evidence of alteration, erasure or forgery of the purchase receipt will also void this warranty.

Australian Monitor accepts no liability for any consequential damages, whether direct or indirect, arising from the use or misuse of its products.

Australian Monitor reserves the right to alter its designs and specifications at any time without notice or obligation to previous purchasers.



Australian Monitor

PA-SERIES 2 YEAR WARRANTY REGISTRATION

IMPORTANT

Please complete this card and return it immediately after unpacking the product.

This card is to be sent DIRECTLY to Australian Monitor.

NOTE! Warranty is effective ONLY upon receipt of this card.

COMPANY _____

NAME _____ MODEL _____

ADDRESS _____ SERIAL N° _____

DATE PURCHASED _____

CITY _____ DEALER _____

STATE _____ CODE _____ COUNTRY _____

Ensure that you fill out and send your warranty registration card.
Use this copy to record a duplicate of the details.



Model: <i>PA1200</i>	Output Power		Model: <i>PA800</i>	Output Power	
E.I.A. 1 kHz, <0.1 % THD+N.	8ohm	4ohm	E.I.A. 1 kHz, <0.1 % THD+N.	8ohm	4ohm
Single channel driven.	440W	680W	Single channel driven.	285W	460W
Both channels driven.	400W	600W	Both channels driven.	255W	400W
Pulsed @ 1 kHz, at onset of clipping, 10% duty cycle, re 4 ohms.			Pulsed @ 1 kHz, at onset of clipping, 10% duty cycle, re 4 ohms.		
Single channel driven.		800W	Single channel driven.		550W
Both channels driven.		750W	Both channels driven.		500W
Bridge mode			Bridge mode		
16 ohm load		800W	16 ohm load		510W
8 ohm load		1200W	8 ohm load		800W
Output Impedance @ 1 kHz	<0.025 ohms		Output Impedance @ 1 kHz	<0.030 ohms	
Damping Factor @ 1 kHz re 8 ohms	>320:1		Damping Factor @ 1 kHz re 8 ohms	>260:1	
Output Rise Time (80%, leading edge of 20kHz square wave)	<2.8µS		Output Rise Time (80%, leading edge of 20kHz square wave)	<2.8 µS	
Slew Rate (leading edge, 20kHz square wave @ clipping)	60V per µS		Slew Rate (leading edge, 20kHz square wave @ clipping)	50V per µS	
Weight Net 37.5 lb (17kg), Shipping 43lb (19.5kg)			Weight Net 33 lb (15kg), Shipping 38.5 lb (17.5kg)		

Common Specifications

Distortion (0.5 dB below clipping re 4 ohms)		Input CMRR	
THD+N (@ 1 kHz)	<0.01%	@ 1 kHz (re 8 ohm rating)	>80 dB
IMD SMPTE (60 Hz & 7 kHz 4:1)	<0.05%	Signal / Noise ratio	
IMD DIM 30 (3.15kHz square & 15 kHz)	<0.02%	"A" weighted (re 8 ohm rating)	>100 dB
Frequency Response		Crosstalk	
20 Hz - 20 kHz	< ± 0.15 dB	@ 1 kHz (re 8 ohm rating)	>90 dB
-3dB points	<10 Hz - 90 kHz	Dimensions	H x W x D
Input Impedance		excluding handles	3.5 x 19 x 14.8 (inch)
Line to Line (Balanced)	30k ohms	including handles	88 x 482 x 375 (mm)
Input Sensitivity (nominally)			3.5 x 19 x 17.7 (inch)
For rated power re 8 ohm	1.26 Vrms (+4 dBu)		88 x 482 x 450 (mm)
For rated power re 4 ohm	1.10 Vrms (+3 dBu)	(19 inch EIA rack mounting, 2 units high)	

Test conditions

Input source = 600 ohm, Balanced and ground referenced (CMRR test had floating ground & 50 ohm source). Mains regulated to 240 volts / 50hz. All measurements taken at binding post output terminals. Standard production units measured. No compensation applied.



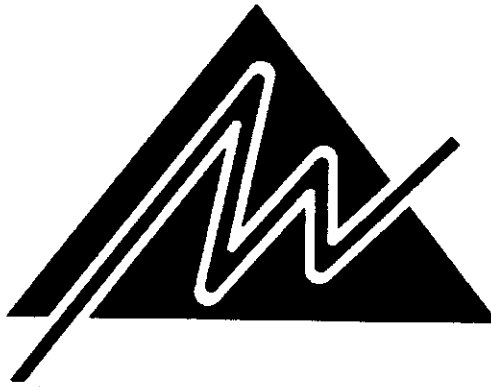

Australian Monitor

Distributed by:
Audio Telex Communications Pty Ltd

ACN 001345482

Australia

www.audiotelx.com

International Enquiries

Ph: 61-2-9647 1411, Fax: 61-2-9748 2537, E-mail: ho@audiotelx.com

Sydney

Ph: (02) 9647 1411, Fax: (02) 9648 3698, E-mail: nsw@audiotelx.com

Melbourne

Ph: (03) 9890 7477, Fax: (03) 9890 7977, E-mail: vic@audiotelx.com

Brisbane

Ph: (07) 3852 1312, Fax: (07) 3252 1237, E-mail: qld@audiotelx.com

Perth

Ph: (08) 9228 4222, Fax: (08) 9228 4233, E-mail: audiotlx@multiline.com.au

Auckland

Ph: (09) 415 9426, Fax: (09) 415 9864, E-mail: audiotlx@nznet.gen.nz

