

Instructions for use



Security Systems

EN | Instructions for use

BOSCH

LBC 1252/00 Wall Mounting Bracket



The LBC 1252/00 wall mounting bracket is actually designed for securing column loudspeakers directly onto a wall. It is made from die-cast aluminum, and includes two lockable swivel joints to allow movement in two perpendicular planes for precise positioning. The mounting hole pitch matches that of the threaded inserts in the back of most of the sound column enclosures.

Technical Specifications

Mechanical

Approx. Dimensions	55 x 85 x 168 mm
Material	Die-cast aluminum
Finish	Glass-blast matt
Mounting Hole Pitch	65 mm
Mounting Hole Dia.	6 mm
Max. Load	10 kg
Weight	395 g

Ordering Information

Model | Description

LBC 1252/00 Wall Mounting Bracket

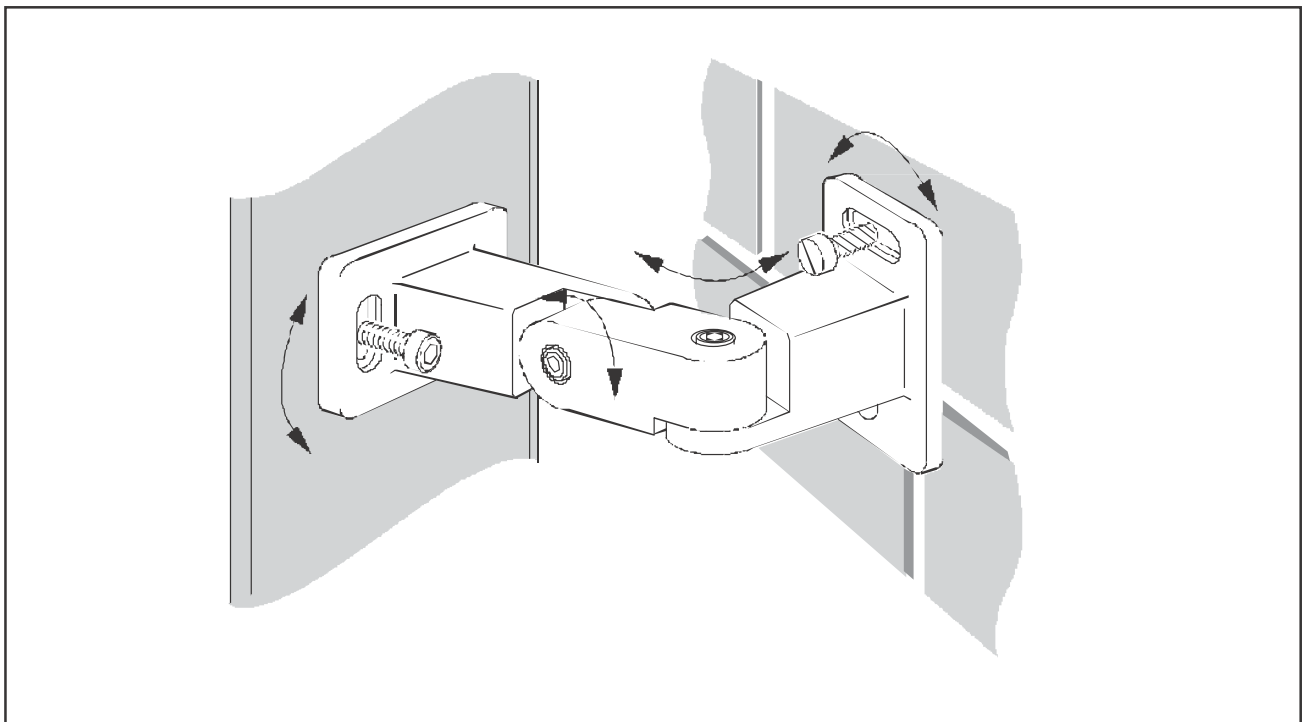

Adjustable mounting bracket

3938 988 05611 45-03
©2003 Bosch Security Systems

BOSCH