

ISP-100

Integrated Signal Processor

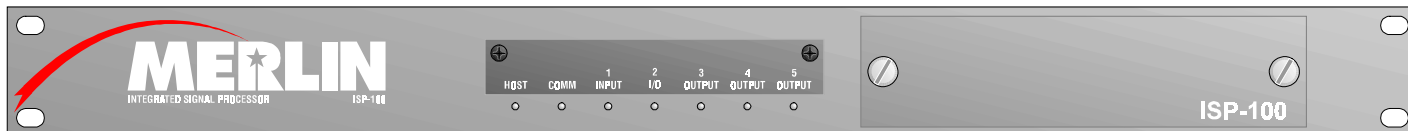

- 20-bit A/D and D/A converters
- 24-bit data processing
- Ergonomically designed software
- Up to eight configurable GPIs
- I/O hardware configurable
- Analog and/or digital I/O
- Enhanced numeric precision

Description

The Merlin™ ISP-100 by EVI Audio provides the tools contractors need to get the job done. They are tools designed to make the user successful at audio, not computer programming. The ISP-100 is designed with flexibility in mind, providing a powerful tool which allows you to adapt to ever-changing applications.

A versatile platform utilizing the latest in DSP technology allows the ISP-100 to quickly adapt to new market demands and continually changing improvements and advancements in the semiconductor industry.

A series of predefined, signal-path topologies, called QuickMAPs™ are offered, which enable the designer to quickly define the processing structure of the system. This approach allows for a continuation of new processing solutions and/or variations, providing "market-specific" templates to help minimize your design time and increase your profit.

Integrated operations and functions simplify the total audio system design. Integration eliminates extensive cabling, connectors and components, along with minimized noise and failures due to cables and solder joints. The result of this consolidation of processing is

overall system performance and audio integrity being greatly increased.

An ergonomically designed software interface called VUE-IT™ provides graphic control panels with the "conventional" look and feel of signal processors. As well, the advanced and easy-to-use filter tool graphically displays the configuration of your filter block settings.

The ISP-100 is designed with modular inputs and outputs. This feature allows the designer or installer to select between analog input or output modules and/or a digital input/output combination module. The modules are two channel units and can be intermixed between analog and digital providing a variety of I/O combination possibilities.

The ISP-100 supports a maximum of four inputs with a maximum of eight outputs. Combinations such as 2 x 2, 2 x 4, 2 x 6, 2 x 8, 4 x 2, 4 x 4, 4 x 6, or for example, two in digital by eight out analog could all be accommodated by simply varying the I/O modules within the same Merlin ISP-100. The current series of QuickMAPs support most of these I/O configurations with more soon to be released.

The ISP-100 provides a dynamic range which rivals anything currently on the market. The Audio Precision System II (the test-

ing standard for digital audio equipment) resolves signals down to -125 dBFS; at this level the ISP-100 is still performing exceptionally. The ISP-100 has a typical noise floor of -107 dBu and an THD+N of 0.004%. Due to the design efficiencies, propagation time is minimized in the ISP-100. No more than two milliseconds of delay is introduced from any analog input to analog output with full processing.

Another measure of the flexibility designed into the ISP-100 is General Purpose Inputs (GPI). GPIs allow multiple system configurations to be selected without the need for a PC to control the unit. GPIs are programmable dry contact closure interfaces which allow user-supplied contact closures to switch system settings directly to a defined program and/or scroll through system settings as desired.

Architects' and Engineers' Specifications

The specified digital audio signal processor shall incorporate three 66 MHz DSP microchips. The processor shall provide a motherboard incorporating 20-bit A/D and D/A input and output module connections allowing user-defined hardware configuration of inputs and outputs. Hardware configurations shall allow the same processor box to be used

ISP-100 Integrated Signal Processor

in 2 x 2, 2 x 4, 2 x 6, 2 x 8, 4 x 2, 4 x 4 and 4 x 6 configurations. The motherboard shall also accept digital audio input from an optional AES/EBU module. Communication exchange between the processor and PC shall be conducted via RS232 serial port. The unit shall provide GPI interfaces with screw-terminal connectors for dry contact closure input. GPIs shall allow user-programmable access to any defined system setting. GPIs shall allow direct access to or scrolling of programmed settings. Up to eight GPIs shall be available with each signal processor.

A/D and D/A modules shall provide a typical noise floor of -107 dBu and THD+N of 0.004%. DSP algorithms shall be calculated using no less than 24-bit processing.

There shall be no user-configurable buttons, knobs or switches immediately accessible on the enclosure of the processor. RS232 port, power switch, hot-swappable battery and factory reset button shall be located behind a front-access cover panel. Front panel LED indicators shall display power on/off, input/output modules installed, signal clipping and host communication status. The unit shall be self contained within a 19-inch single rack space (1 RU) chassis.

Software environment for configuring the processor shall provide static system topology maps which provide direct access to displayed processor options. The software shall provide a stable interface environment in Windows™ 3.1/3.11 and Windows 95™.

The specified digital signal processor shall be a MERLIN ISP-100.

Uniform Limited Warranty Statement

EVI Audio products are guaranteed against malfunction due to defects in materials or workmanship for a specified period, as noted in the individual product-line statement(s) below, or in the individual product data sheet or owner's manual, beginning with the date of original purchase. If such malfunction occurs during the specified period, the product will be repaired or replaced (at our option) without charge. The product will be returned to the customer prepaid. **Exclusions and Limitations:** The Limited Warranty does not apply to: (a) exterior finish or appearance; (b) certain specific items described in the individual product-line statement(s) below, or in the individual product data sheet or owner's manual; (c) malfunction resulting from use or operation of the product other than as specified in the

product data sheet or owner's manual; (d) malfunction resulting from misuse or abuse of the product; or (e) malfunction occurring at any time after repairs have been made to the product by anyone other than Merlin Service or any of its authorized service representatives. **Obtaining Warranty Service:** To obtain warranty service, a customer must deliver the product, prepaid, to Merlin Service or any of its authorized service representatives together with proof of purchase of the product in the form of a bill of sale or receipted invoice. A list of authorized service representatives is available from Merlin Service at 10500 W. Reno Avenue, Oklahoma City, OK 73127 (800-283-8325 or FAX 405-324-8981). **Incidental and Consequential Damages Excluded:** Product repair or replacement and return to the customer are the only remedies provided to the customer. Merlin shall not be liable for any incidental or consequential damages including, without limitation, injury to persons or property or loss of use. Some states do not allow the exclusion or limitation of incidental or consequential damages so the above limitation or exclusion may not apply to you. **Other Rights:** This warranty gives you specific legal rights, and you may also have other rights which vary from state to state.

Figure 1— Compressor, Hard and Soft Knee

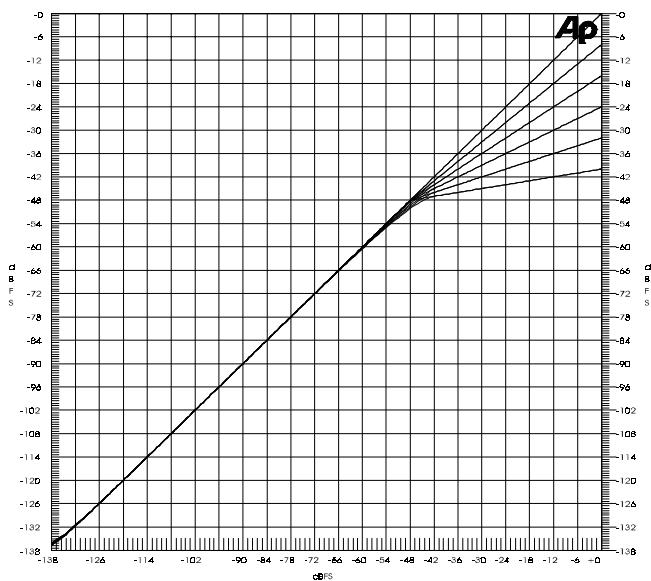
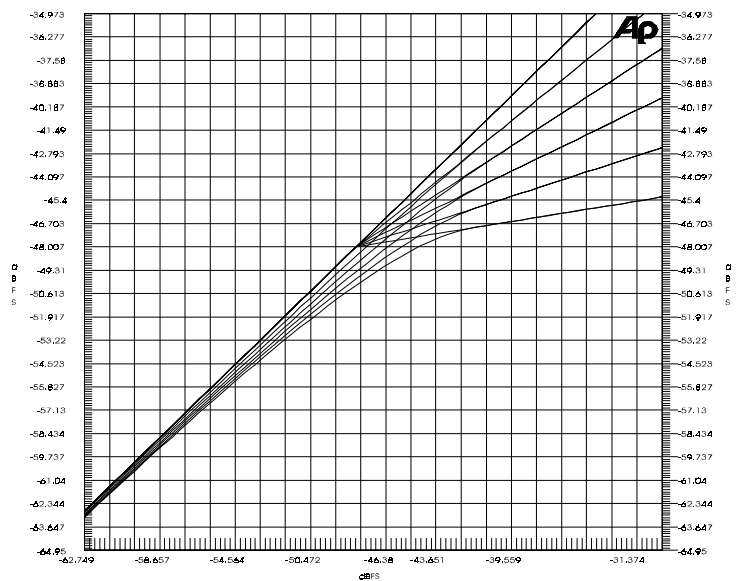

Figure 2— Compressor Detail, Hard and Soft Knee



ISP-100 Integrated Signal Processor

Figure 3— Linkwitz-Riley 3-Way Crossover

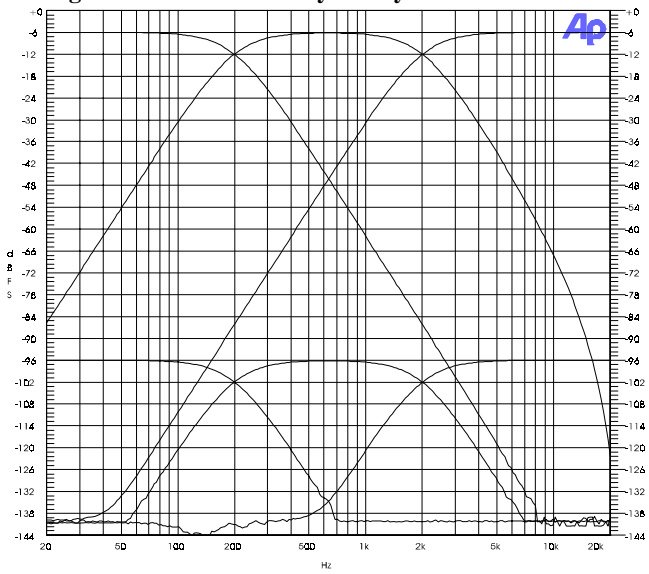

Figure 4— Parametric Equalizer Filter

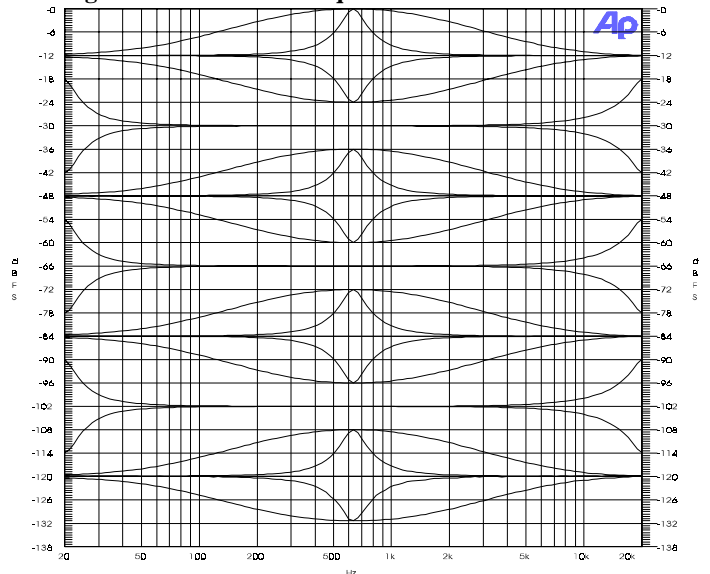

Figure 5— Notch Filter

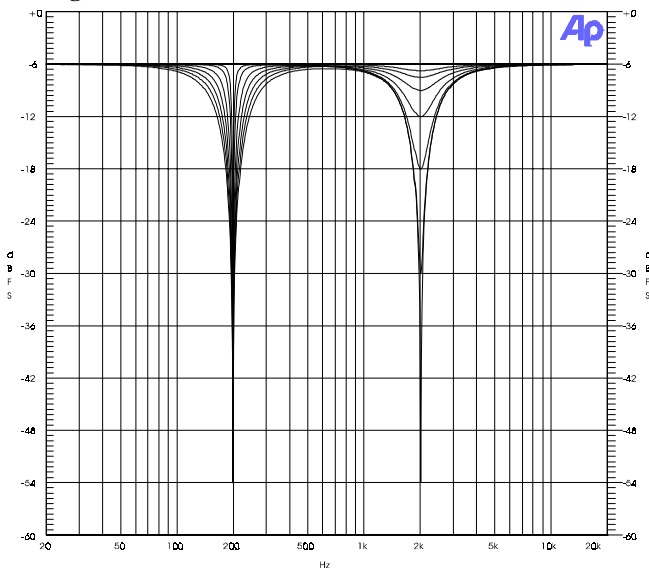
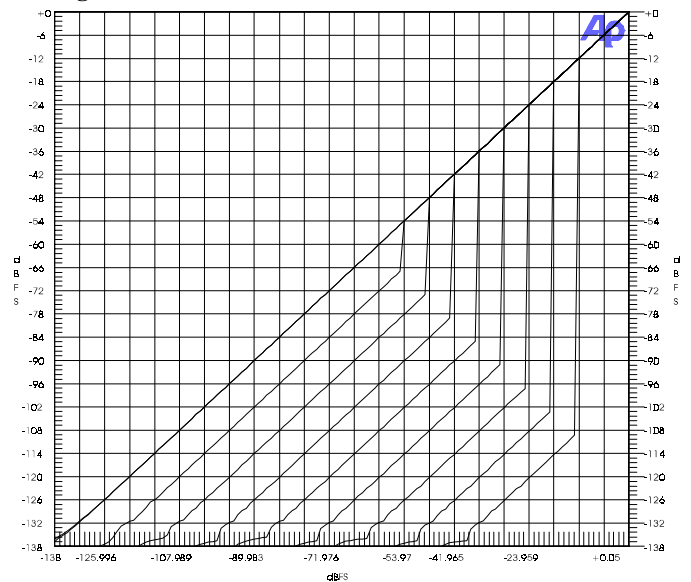

Figure 6— Gate



General Specifications

Input/Output Modules

Modular, 2-channel,
20-bit A/D and D/A converters

Noise Floor

-107 dBu, typical

THD+N

0.004%, typical

Inherent Delay

no more than 2 msec
from any analog in
to any analog out
with full processing

Component Specifications

Compressor:

Threshold -60 dB to 0 dB

Compression Ratio

1.2, 1.5, 2.0, 3.0, 4.0, 6.0,
8.0, 12.0, 16.0, 24.0

Detection Window

20 usec to 5 sec

Crest Factor Sensitivity

average to peak

Attack Time 20 usec to 50 msec

Release Time 20 usec to 5 sec

Knee Selection Hard/Soft

Sidechain Channel Selection

input to any compressor
resident in same DSP

Delay:

Delay Time 0 sec to 650 msec

Dither (metered):

Levels 16 bits to 24 bits

Attenuation/Absolute Polarity:

Gain 0 dB to -96 dB, mute

Absolute Polarity +/-

Gate:

Threshold -60 dB to 0 dB

Attenuation 0 dB to -100 dB

Detection Window

20 usec to 5 sec

Attack Time 20 usec to 50 msec

Release Time 20 usec to 5 sec

Key Channel Selection

input to any gate resident
in same DSP

ISP-100 Integrated Signal Processor

Rear View of Merlin ISP-100

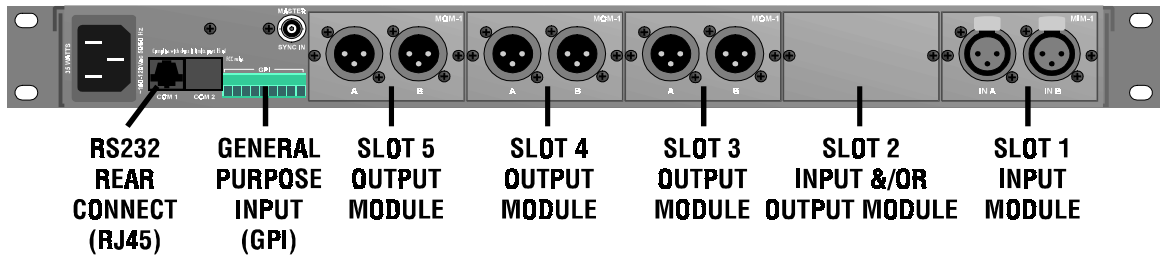

Dual Straight Through QuickMAP

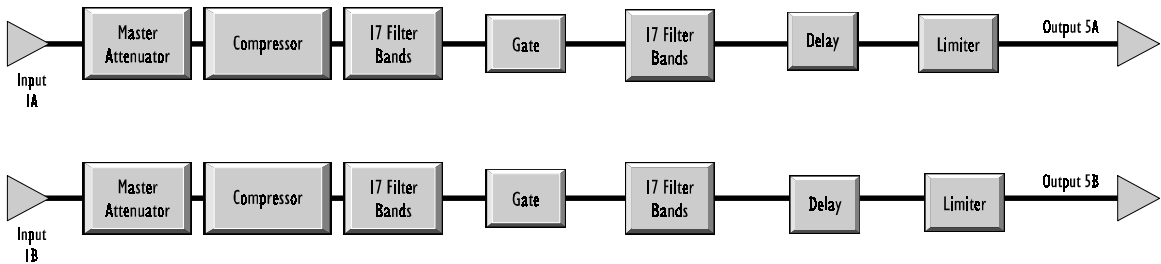

Dual 2-Way Crossover QuickMAP

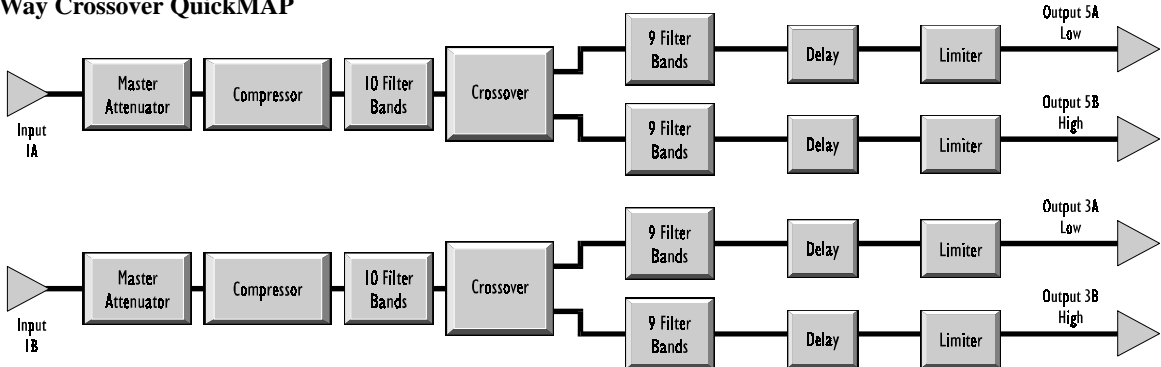

Dual 3-Way Crossover QuickMAP

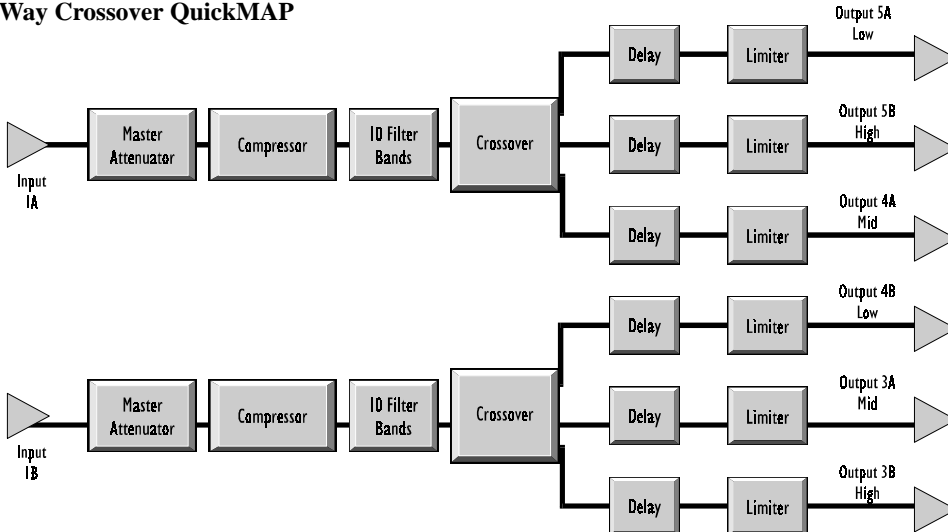

ISP-100 Integrated Signal Processor

Dual 2-Way Crossover with Full Range QuickMAP

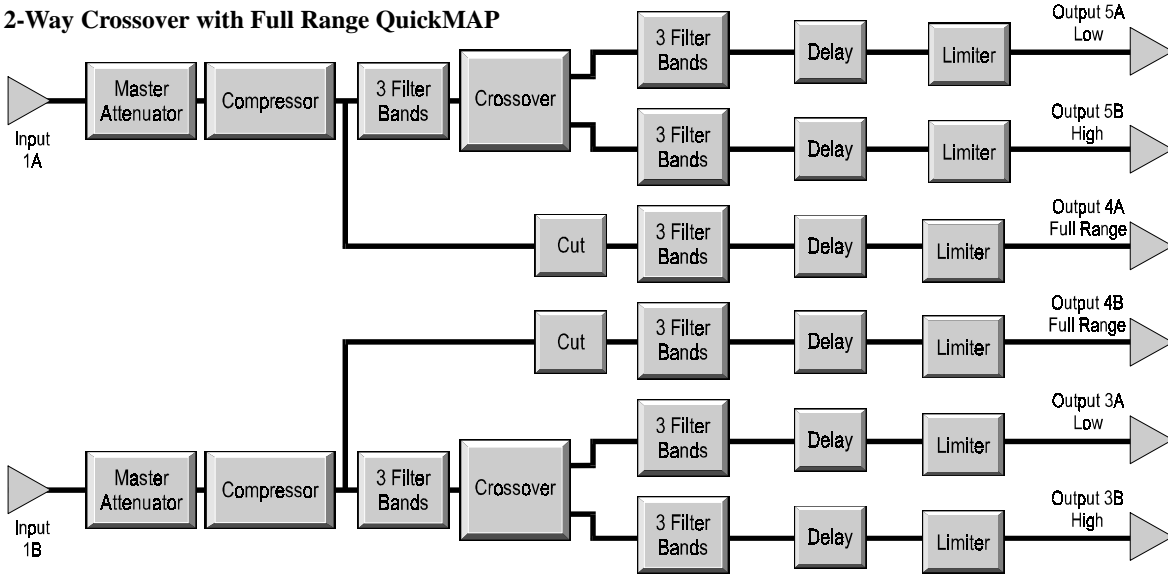

Dual 2-Way Crossover with Center Sub/Mono QuickMAP

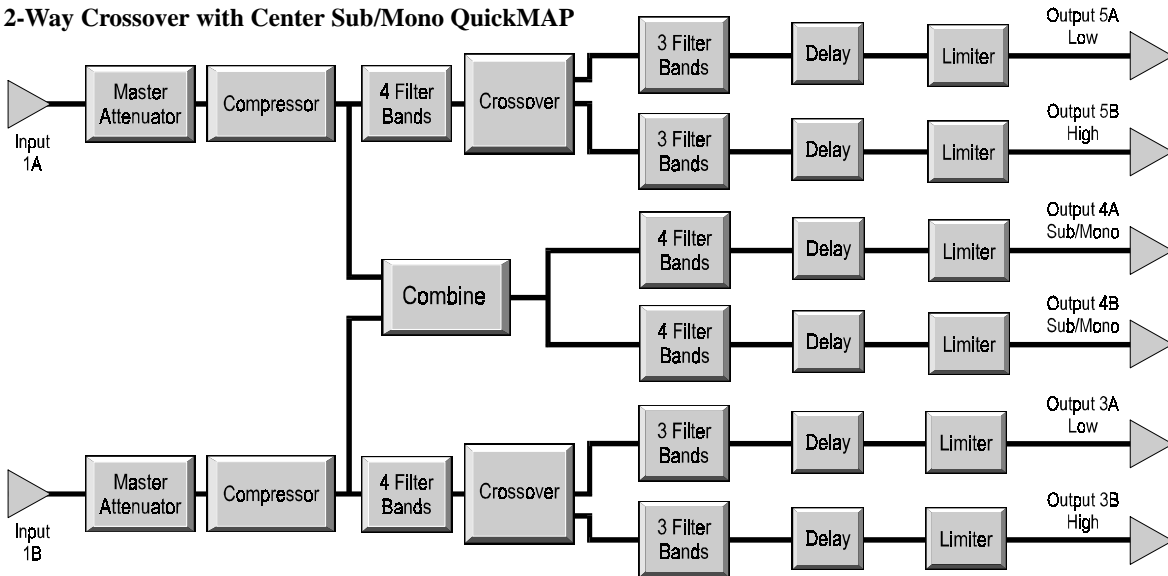

4-Way and 2-Way Crossover QuickMAP

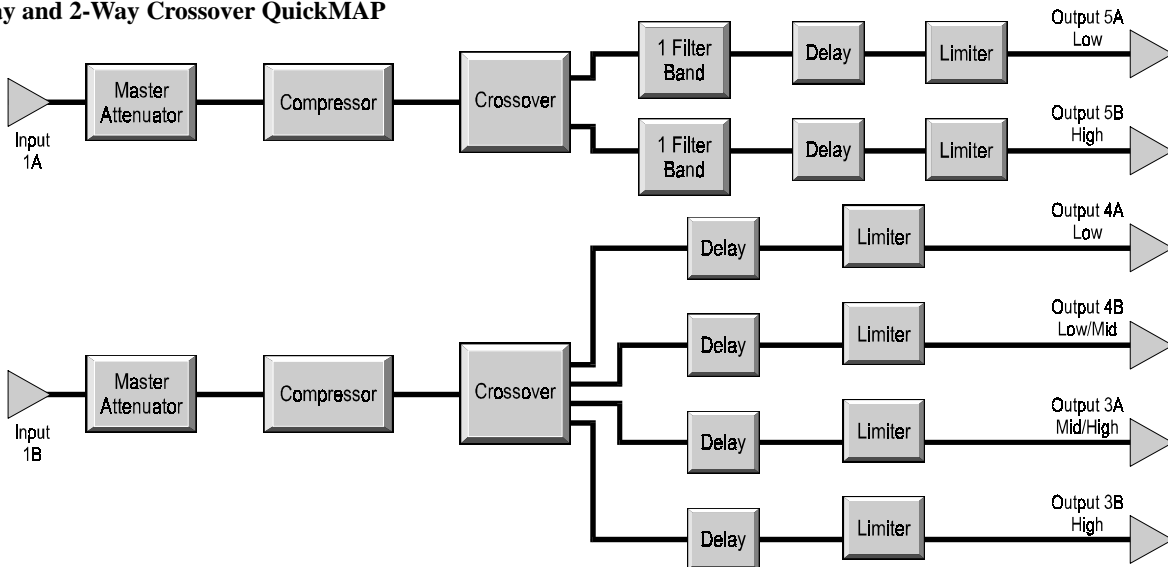

ISP-100 Integrated Signal Processor

ISP-100 Integrated Signal Processor

Input Gain/Absolute Polarity:
(Master Attenuator)
Gain +18 dB to -96 dB, mute
Absolute Polarity +/-

Limiters:
Threshold -60 dB to 0 dB
Detection Window
20 usec to 5 sec
Crest Factor Sensitivity
average to peak
Attack Time 20 usec to 50 msec
Release Time 20 usec to 5 sec
Knee Selection Hard/Soft

Filter Specifications

Filter Types:
low pass, high pass, all pass,
low shelf, high shelf, notch,
parametric EQ, peaked high pass
Absolute Polarity +/-
Gain Trim +12 dB to -12 dB

Low-Pass Filter:
Filter Order (slope)
1 (6 dB/octave), 2 (12 dB/octave),
3 (18 dB/octave), 4 (24 dB/octave)
Cutoff Frequency
20 Hz to 20 kHz
Class Bessel, Butterworth,
Linkwitz-Riley

High-Pass Filter:
Center Frequency
20 Hz to 20 kHz
Filter Order (slope)
1 (6 dB/octave), 2 (12 dB/octave),
3 (18 dB/octave), 4 (24 dB/octave)
Cutoff Frequency
20 Hz to 20 kHz
Class Bessel, Butterworth,
Linkwitz-Riley

All-Pass Filter:
(phase compensation for Linkwitz-Riley
crossover element)
Center Frequency 20 Hz to 20 kHz
Filter Order
1 (compensation for 2nd order
Linkwitz-Riley)
2 (compensation for 4th order
Linkwitz-Riley)

Low-Shelf Filter:
Filter Order (slope)
1 (6 dB/octave), 2 (12 dB/octave)
Cutoff Frequency
20 Hz to 20 kHz
Boost/Cut +12 dB to -12 dB

High-Shelf Filter:
Filter Order (slope)
1 (6 dB/octave), 2 (12 dB/octave)
Cutoff Frequency
20 Hz to 20 kHz
Boost/Cut +12 dB to -12 dB

Notch Filter:
Center Frequency
20 Hz to 20 kHz
Cut 0 dB to -50 dB
Notch Width 1/12 to 1 octave

EQ Filter:
Center Frequency
20 Hz to 20 kHz
Boost/Cut +12 dB to -12 dB
Bandwidth (Q) 1/12 to 3 octave

Peaked High-Pass Filter:
Cutoff Frequency
20 Hz to 20 kHz
Boost 0 dB to +20 dB

Crossover Specifications

2-Way Crossover:
Low/High Passband Gain
0 dB to -96 dB
Order (slope) Class
1st (6 dB/octave)
2nd (12 dB/octave) Bessel,
Butterworth, Linkwitz-Riley
3rd (18 dB/octave) Bessel,
Butterworth
4th (24 dB/octave) Bessel,
Butterworth, Linkwitz-Riley
Low/High Cutoff Frequency
20 Hz to 20 kHz
Absolute Polarity +/-; each band

3-Way Crossover:
Low/Mid/High Passband Gain
0 dB to -96 dB
Order (slope) Class
1st (6 dB/octave)
2nd (12 dB/octave) Bessel,

Butterworth, Linkwitz-Riley
3rd (18 dB/octave) Bessel,
Butterworth
4th (24 dB/octave) Bessel,
Butterworth, Linkwitz-Riley
Low/Mid/High Cutoff Frequency
20 Hz to 20 kHz
Channel 'n' Entry Gain
0 dB to -96 dB
Channel 'n' Absolute Polarity
+/-
(where 'n' represents a specific channel
configuration within the hardware and
software)

4-Way Crossover:
**Low/Low Mid/Mid High/High Passband
Gain**

0 dB to -96 dB
Order (slope) Class
1st (6 dB/octave)
2nd (12 dB/octave) Bessel,
Butterworth, Linkwitz-Riley
3rd (18 dB/octave) Bessel,
Butterworth
4th (24 dB/octave) Bessel,
Butterworth, Linkwitz-Riley

**Low/Low Mid/Mid High/High Cutoff
Frequency**
20 Hz to 20 kHz
Channel 'n' Entry Gain
0 dB to -96 dB

Channel 'n' Absolute Polarity
+/-
(where 'n' represents a specific channel
configuration within the hardware and
software)

Combiner:
Channel 1 Exit Gain
0 dB to -96 dB
Channel 1 Exit Absolute Polarity
+/-

Channel 'n' Exit Gain
0 dB to -96 dB
Channel 'n' Absolute Polarity
+/-
(where 'n' represents a specific channel
configuration within the hardware and
software)

MERLIN
INTEGRATED SIGNAL PROCESSING

600 Cecil Street, Buchanan, MI 49107
616/695-6831, Fax 616/695-1304