



# 2404H Ultra-High Frequency Transducer

Professional Series

## Key Features:

- ▶ Bi-Radial<sup>®</sup> Constant-Coverage horn design
- ▶ Constant 100° x 100° dispersion from 3 kHz to 20 kHz
- ▶ 40 watts continuous program
- ▶ 3 kHz to 21.5 kHz response
- ▶ Annular-ring diaphragm ferrite motor structure
- ▶ 44 mm (1<sup>3/4</sup> in) edgewound aluminum ribbon voice coil
- ▶ 105 dB sensitivity, 1 W, 1 m (3.3 ft)

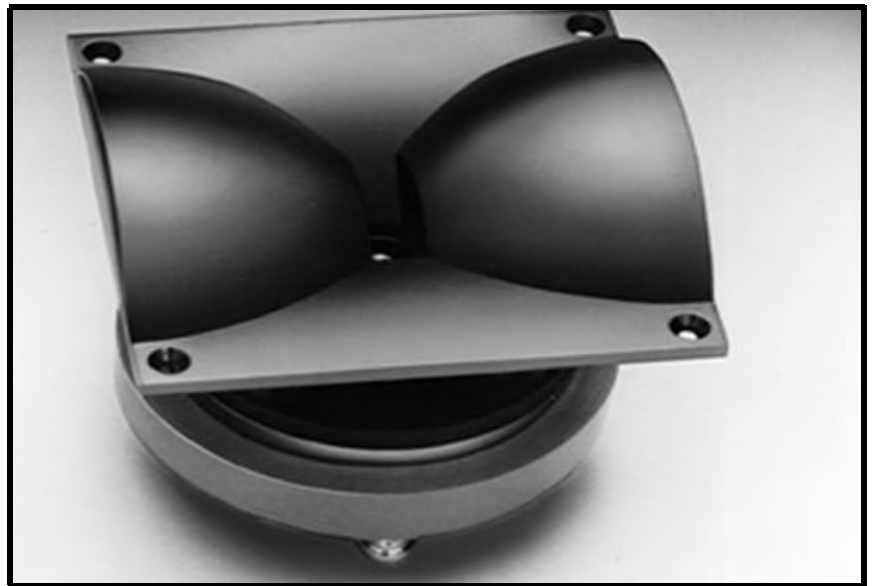

Designed for use as an ultra-high frequency driver in multi-element, full range loudspeaker systems, the JBL Model 2404H delivers an unmatched combination of wide, tightly controlled dispersion, extended frequency response, high power capacity, and high efficiency

One key to this outstanding performance lies in the unique geometry of the driver's Bi-Radial horn<sup>1</sup>. Developed with the aid of the latest computer design and analysis techniques, the horn provides constant coverage from its recommended crossover point of 3 kHz to beyond 20 kHz. The Bi-Radial compound flare configuration maintains precise control of the horn's wide 100° x 100° coverage angle, and the horn's rapid flare rate dramatically reduces second harmonic distortion. The uniform coverage of the horn is illustrated by the detailed polar data and the isobar (constant sound pressure) contours included in this specification sheet. The polar curves of the 2404 exhibit soft-edge pattern characteristics, due to the gradual drop-off of level with increasing off-axis angle.

## Specifications:

Nominal Impedance:	8 ohms
Minimum Impedance:	7.2 ohms @ 3 kHz
Power Capacity <sup>1</sup> :	40 watts continuous program at 3 kHz or higher, 12 dB/octave slope
Sensitivity <sup>2</sup> :	105 dB SPL (1 W, 1 m)
Frequency Response (± 3 dB):	4 kHz to 19 kHz
Usable Frequency Range (- 10 dB):	3 kHz to 21.5 kHz
Coverage Angles:	(Included angle between 6 dB down points, rated over 3.15 kHz to 20 kHz)
Horizontal Angle:	100 (+ 47, - 10)°
(Flange mounting holes on top and bottom)	
Vertical Angle:	100 (+ 42, - 14)°
(Flange mounting holes on right and left)	
Directivity Factor (Q):	6.8 (+ 1.5, - 2.3)
(Averaged over 3.15 kHz to 20 kHz)	
Directivity Index (Di):	8.3 (+ 0.9, - 1.8)
(Averaged over 3.15 kHz to 20 kHz)	
Recommended Crossover:	3 kHz or higher
(With minimum 12 dB/octave slope)	
Diaphragm:	0.05 mm (0.002 in) Aluminum alloy
Diaphragm Diameter:	44 mm (1 <sup>7/8</sup> in)
Voice Coil Diameter:	44 mm (1 <sup>7/8</sup> in)
Voice Coil Material:	Edgewound aluminum ribbon
Magnetic Assembly Weight:	1.9 kg (4.1 lb)
Flux Density:	1.75 T (17,500 gauss)
Force Factor (B1):	5.25 N/A
Positive voltage to black terminal gives forward diaphragm motion	
Dimensions:	
Flange Height:	130 mm (5.12 in)
Flange Width:	130 mm (5.12 in)
Depths <sup>3</sup> :	
Overall:	128 mm (5 in)
Behind Baffle:	96 mm (3.76 in)
In Front of Baffle:	32 mm (1.25 in)
Baffle Cutout Diameters:	122 mm (4 <sup>7/8</sup> in)
Net Weight:	2.27 kg (5 lb)
Shipping Weight:	2.72 kg (6 lb)

<sup>1</sup>Continuous program power is defined as 3 dB greater than continuous sine wave power and is a conservative expression of the transducer's ability to handle normal speech and music program material. Below 2 kHz the input power should be limited to 5 watts (6.3 V RMS) or less.

<sup>2</sup>Axial level, 2.83 V RMS input, averaged over 3 kHz to 20 kHz.

<sup>3</sup>These dimensions apply to front mounting of the 2404 assembly. Rear mounting is not recommended due to the possible interference with the wide angular coverage pattern of the horn.

# ▶ 2404H Ultra-High Frequency Transducer

The coverage pattern of the Bi-Radial horn provides precise pattern control and excellent frequency response even at extreme oblique off-axis angles (off-axis both horizontally and vertically). This behavior is illustrated in this specification sheet with polar data taken at an oblique angle of 45° in addition to the usual horizontal and vertical polar curves. Additional data on the directional characteristics of the 2404 is illustrated in 10 kHz octave bandwidth isobar contours. These contours represent the sound pressure distribution in the front hemisphere of the horn. The contours show the excellent symmetrical soft-edge coverage that the Bi-Radial horn provides.

Coupled to the horn is a constant area phasing plug and an annular ring diaphragm ferrite motor structure.

The phasing plug maintains constant phase and amplitude. The annular voice coil diaphragm is pneumatically formed of fatigue-resistant aluminum and utilizes an optimally constructed voice coil former and the latest in high temperature adhesive technology to substantially increase the driver's power capacity. A ferrite magnetic structure provides a high flux level for extended response and maximum efficiency while maintaining traditional JBL tolerances in assembly and manufacture.

1 Patent No. 4,308,932. Further information on the Bi-Radial horns can be found in a paper by D. Smith, D Keefe, and J Eargle, Improvements in Monitor Loudspeaker Systems, presented at the 69th Convention of the Audio Engineering Society (May 1981). AES Preprint 1784 (F-4) available from JBL Professional.

## Architectural Specifications:

The transducer shall have a measured sensitivity (SPL at 1 m with a 1 W input swept from 3 kHz to 20 kHz) of at least 105 dB on axis. On-axis frequency response measured under free field conditions at a distance of 1 m (3.3 ft) or more shall extend from 3 kHz to 20 kHz.

Horizontal and vertical dispersion shall be a constant 100° x 100° from 3 kHz to 20 kHz when measured at the 6 dB down points relative to on-axis frequency response characteristics using 1/3-octave band pink noise as the signal source. Nominal impedance shall be 8 ohms and power capacity shall be at least 40 watts normal program material.

The transducer shall have a maximum flange size of 130 mm x 130 mm (5.12 in x 5.12 in) and a depth of 128 mm (5 in) and weigh not less than 11 kg (5 lb). The horn shall be injection molded structural foam polycarbonate.

All magnetic assembly parts shall be machined from cast or extruded billet stock.

Voice coil diameter shall be 44 mm (1.73 in), operating in a magnetic field whose flux density measures at least 1.75 tesla (17,500 gauss). Voice coil wire shall be aluminum, milled to a ribbon then wound by hand on its edge and mated to an anodized aluminum diaphragm.

The transducer shall be JBL Model 2404H.

JBL continually engages in research related to product improvement. New materials, production methods, and design refinements are introduced into existing products without notice as a routine expression of that philosophy. For this reason, any current JBL product may differ in some respect from its published description, but will always equal or exceed the original design specifications unless otherwise stated.

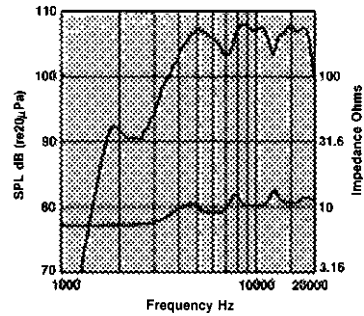

### Frequency response and impedance.

Frequency response of the 2404, measured on axis at a distance of 1 meter with 1 watt (2.83 V RMS) applied, in a reflection-free environment, with impedance vs frequency curve. Unit free standing (without baffle).

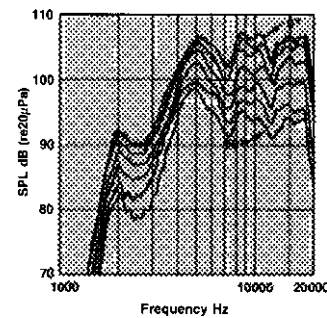

### Horizontal off-axis response.

Horizontal off-axis response taken at 15 degree intervals out to 90 degrees off axis.

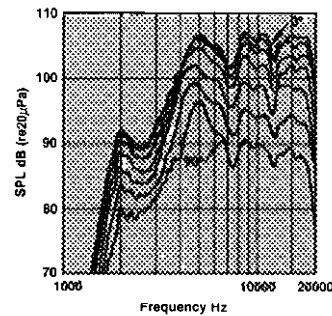

### Vertical off-axis response.

Vertical off-axis response taken at 15 degree intervals out to 90 degrees off axis.

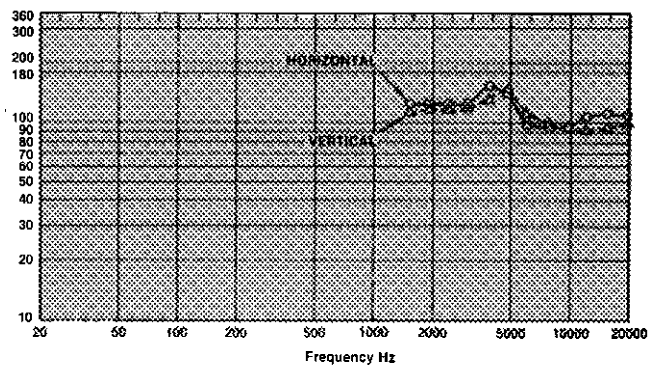

Beamwidth (-6 dB) vs Frequency.

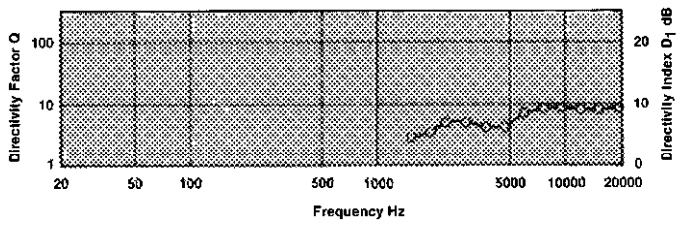

**Directivity vs Frequency**

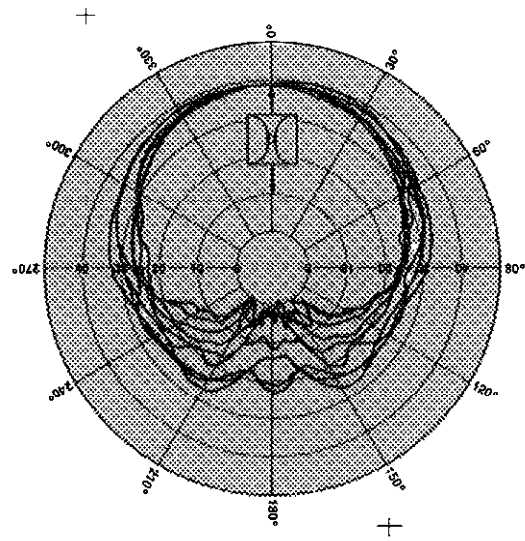

**Horizontal polar response.**

Composite  $\frac{1}{3}$ -octave polar bandwidth responses of the 2404 in the horizontal plane over the range of 3.15 kHz to 20 kHz (1 meter measurement distance in an anechoic chamber, all polars normalized to on axis). Unit free standing (without baffle).

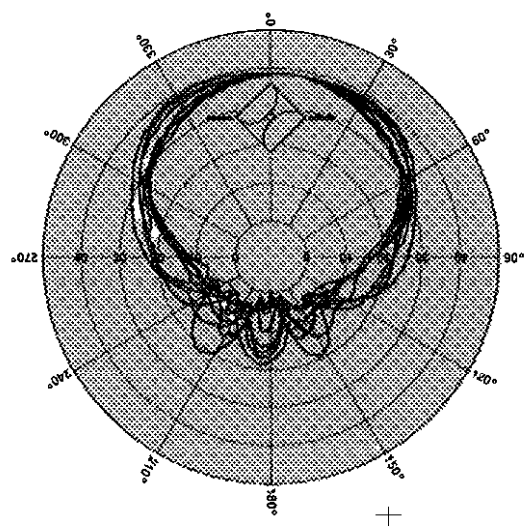

**Oblique polar response.**

Composite polar response of the 2404 in an oblique plane tilted at an angle of 45 degrees. Same test condition as horizontal.

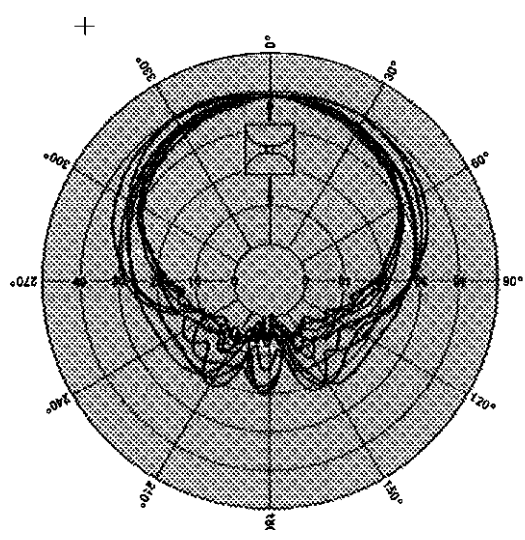

**Vertical polar response.**

Composite polar responses of the 2404 in the vertical plane. Same test conditions as horizontal.

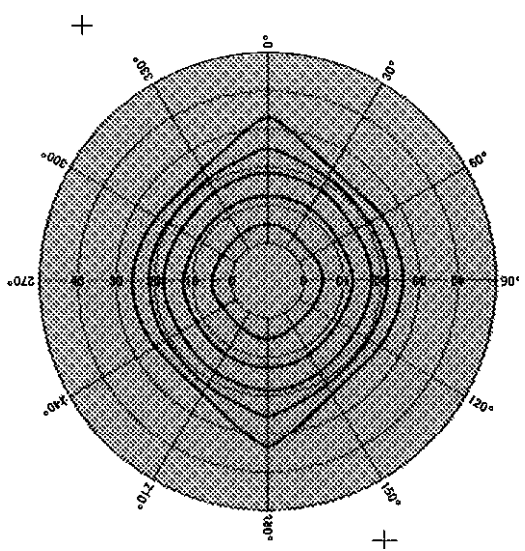

**Frontal isobar contours.**

10 kHz octave bandwidth (7.07 kHz to 14.14 kHz) constant sound pressure contours of 0 to -15 dB in steps of -3 dB. The contours are plotted on polar grid lines with 0° on axis being the center of the plot. The data was gathered by taking an octave polar plot at all oblique angles from 0° (horizontal) to 90° (vertical) in steps of 15°. Same test conditions as horizontal polar response.

## ▶ 2404H Ultra-High Frequency Transducer

---



JBL Professional  
8500 Balboa Boulevard, P.O. Box 2200  
Northridge, California 91329 U.S.A.

 A Harman International Company

SS 2404H  
CRP 5M  
10/96