

# VA VA OO VA

*S E R I E S*

---

Introduction	5
Quick Set-Up Guide	6
Features	7
Placement	8
Connection	9
Power Requirements	9
Component Repair/Replacement	10/14
Specifications	15

Congratulations on choosing JBL 4400A Series Studio Monitors. You have selected the highest quality compact monitors designed specifically for the musical needs of the 90's and beyond. Designed for maximum sonic accuracy, achieved through balanced frequency response, low distortion characteristics, and controlled off-axis response, 4400A Series monitors significantly reduce the elements that can cause listener fatigue when compared to other monitors, and set a new standard of performance.

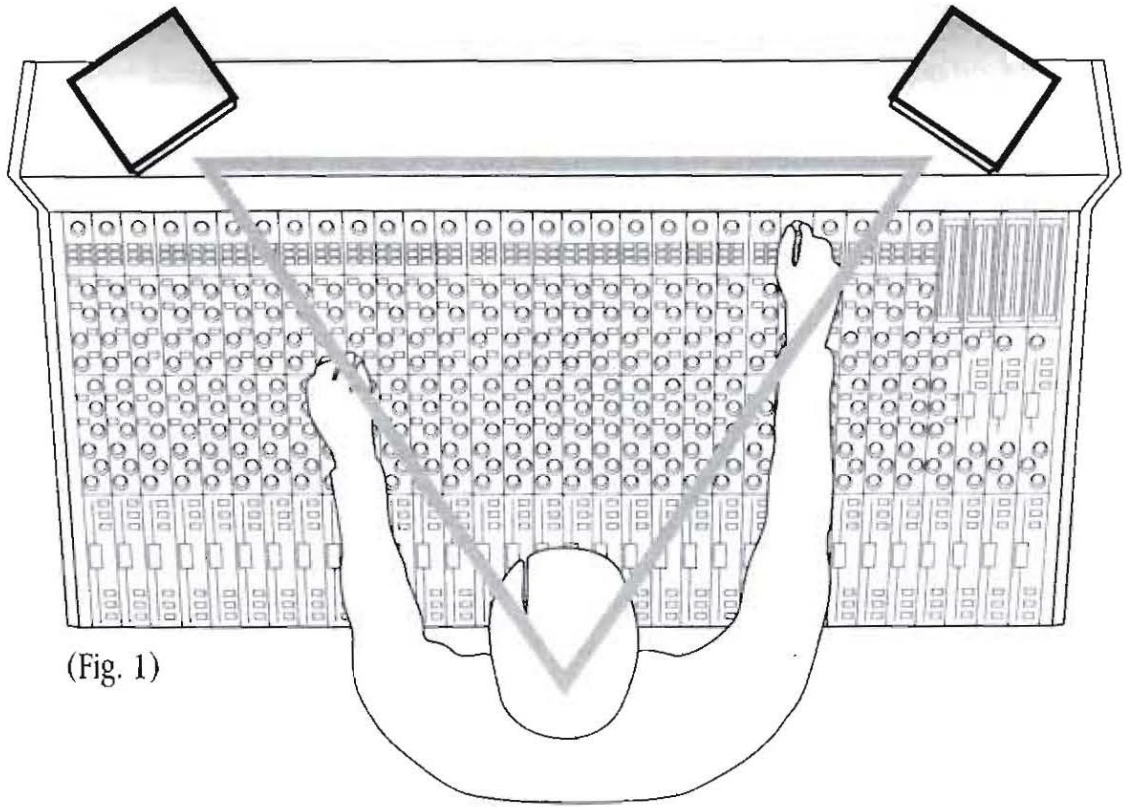

(Fig. 1)

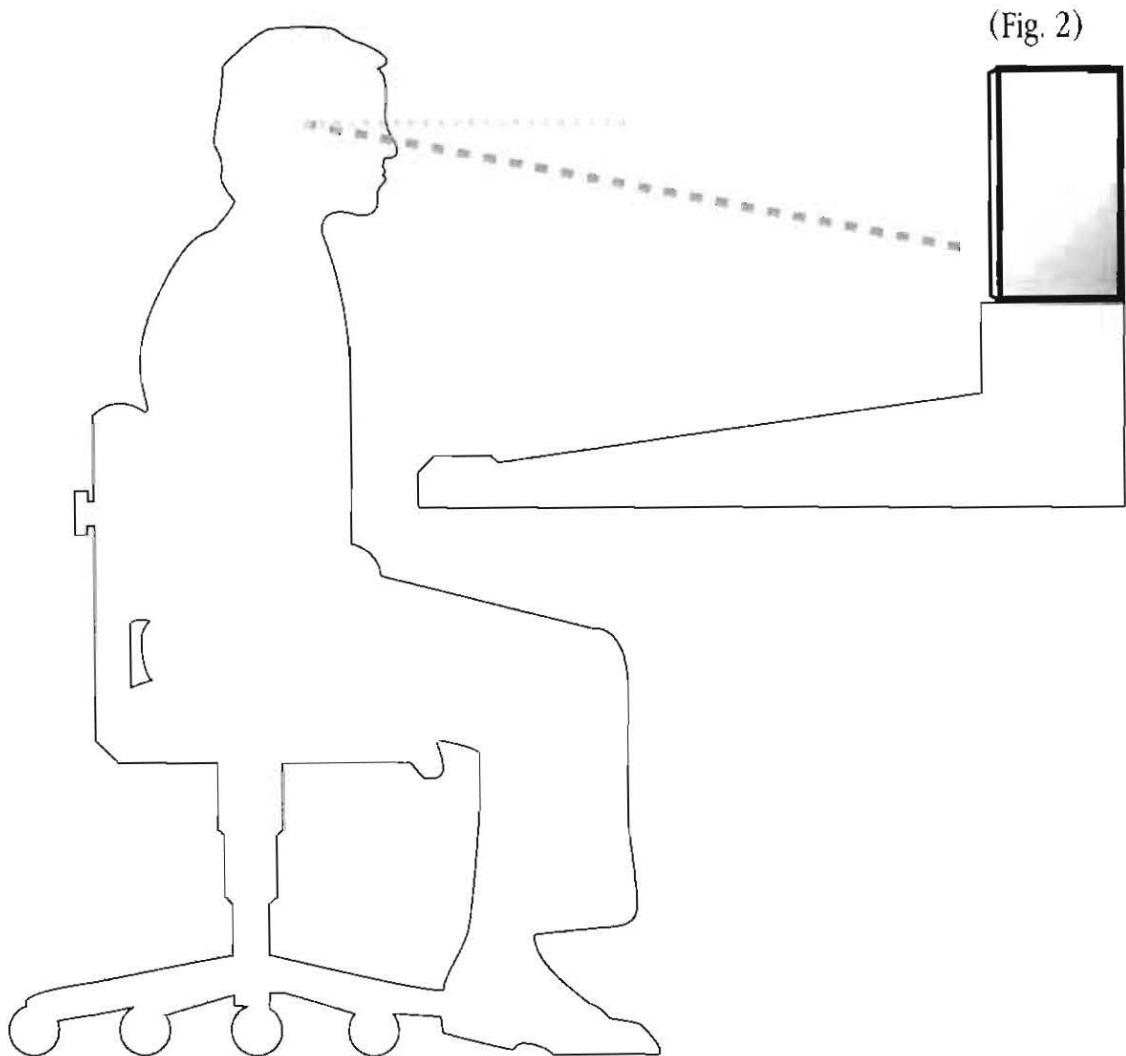

(Fig. 2)

---

Compact studio monitors are most often used in smaller control rooms, positioned fairly close to the listener. As shown in the illustration (Fig.1), the ideal positioning for monitors in close-proximity applications is atop or just behind the console meter bridge, approximately 1 - 1.5 meters (3 - 5 ft) from the typical listening position. They can be positioned further away if necessary, without compromising performance. For best results, particularly with regards to optimum stereo imaging, position the two loudspeakers so that they form an equal-sided (equilateral) triangle with the listener. The high frequency on-axis output should be aligned at the listener eye level, just above ear level (Fig. 2).

---

## Features

JBL 4400A Series monitors are the result of years of experience in the design and manufacture of precision loudspeaker components and systems for studio monitor applications. Numerous recordings, as well as television and movie soundtracks have been mixed over the previous 4400 Series, establishing a reputation for excellence that would be hard to top. To meet the challenge, JBL engineers consulted a number of recording/mixing engineers to quantify their individual needs from a monitor loudspeaker. Prototypes were repeatedly auditioned in working commercial studios to subjectively and scientifically measure acoustical impact of reflections off the mixing console, typical listening distances and ear level as well as other elements of the listening environment. This data, along with that gathered through traditional laboratory testing methods and extensive listening sessions by JBL staff, revealed key design considerations that are clearly addressed in the 4400A Series.

The result is 4400A Series: mirror-imaged systems that deliver the lowest possible distortion, extremely smooth frequency response, high power handling and superb imaging.

## Placement

4400A Series monitors are available as mirror-imaged pairs to achieve a symmetrical wavefront. For best results, there are a few general placement guidelines that should be followed. They are:

*1. Listening Distance:* Having evaluated numerous studio environments, it was determined that close-proximity monitors are generally placed 1 to 1.5 meters (3 to 5 ft) from the common listening position, typically over the meter bridge or just behind on stands. While 4400A Series monitors will deliver excellent performance at almost any listening distance, the 1 to 1.5 meter range usually provides greater control over listening room interaction, particularly when the control room is not an optimized control room. With this in mind, please see Fig. 1, “Quick Set-Up Guide” for a visual guide on recommended placement and positioning.

*2. Vertical vs. Horizontal Orientation:* Models 4408A and 4410A were engineered to deliver best results when positioned vertically. However, the 4408A can also be used horizontally with minimal impact on performance. The 4412A is designed to be positioned horizontally.

*3. Angling Towards the Listening Area:* As illustrated in Fig. 1, the monitors should be angled so they directly face the listener. The center of the high frequency transducer should be on axis with the listener eye level.

*4. Placement Near Walls:* In a typical commercial studio environment, close-proximity monitors are usually located in a fairly open area, away from walls. However, the limited space in most home studios or video post production work centers often places the loudspeakers near walls or corners of the room. You should keep in mind that the placement of any speaker system near a wall(s) will affect low frequency response and change the system’s tonal balance. 4400A Series monitors exhibit the most balanced frequency response when located away from walls.

---

5. *Mirror-Imaging - Which is 'Left' and Which is 'Right'?*: As previously mentioned, 4400A Series monitors are available as mirror-imaged pairs. In other words, there are units that are designated as 'Left' and 'Right'. Under normal circumstances, the high frequency elements are to be located to the outside edge of the enclosure. Again, referring to the "Quick Set Up Guide" and Fig. 1, the ideal set-up is that of an equilateral triangle where the speakers are as far apart from each other as they are from you. Should your space/placement restrictions force you to place the loudspeakers farther apart than their distance from you, locating the high frequency elements to the inside may yield better imaging.

6. *Stray Magnetic Fields*: 4400A Series monitors contain extremely high quality components that depend on powerful magnets for superior performance. The high flux of these magnets can cause stray magnetic fields to affect the performance of video monitors, computers or other magnetically sensitive equipment. It is recommended that these monitor loudspeakers be placed no closer than 450 mm (approximately 18 inches) to magnetically sensitive equipment. Should you need magnetically shielded loudspeaker systems, please contact your local JBL dealer or the factory for information on Control Series or 4200 Series monitors.

---

## Connection

4400A Series monitors are equipped with 5-way binding post input connectors. Positive voltage to the "Red" (+) terminal will produce a forward motion in the low frequency cone. The connectors are designed to accept up to 12 AWG bare wire, Spade Lugs or a standard Banana jack. Spacing of the two input terminals is intended to allow use of a standard Dual Banana jack.

Use only two-conductor insulated speaker wire, preferably of a gauge no smaller than 16 AWG. Cable runs exceeding 10 meters (30 ft) should be made with a heavier wire, 14 or 12 AWG.

---

## Power Requirements

As a generally safe guideline, JBL recommends that your power amplifier's output rating be no less than the rated maximum power handling of the loudspeaker system. A quite common but inaccurate assumption is that a power amplifier whose output power rating is lower than the stated speaker power handling is incapable of damaging the loudspeaker. To the contrary! The highest percentage of component failures occur when the amplifier cannot deliver clean, undistorted power to the loudspeakers. For a more detailed explanation, write to JBL and request the Technical Note entitled "Danger: Low Power."

## 4408A

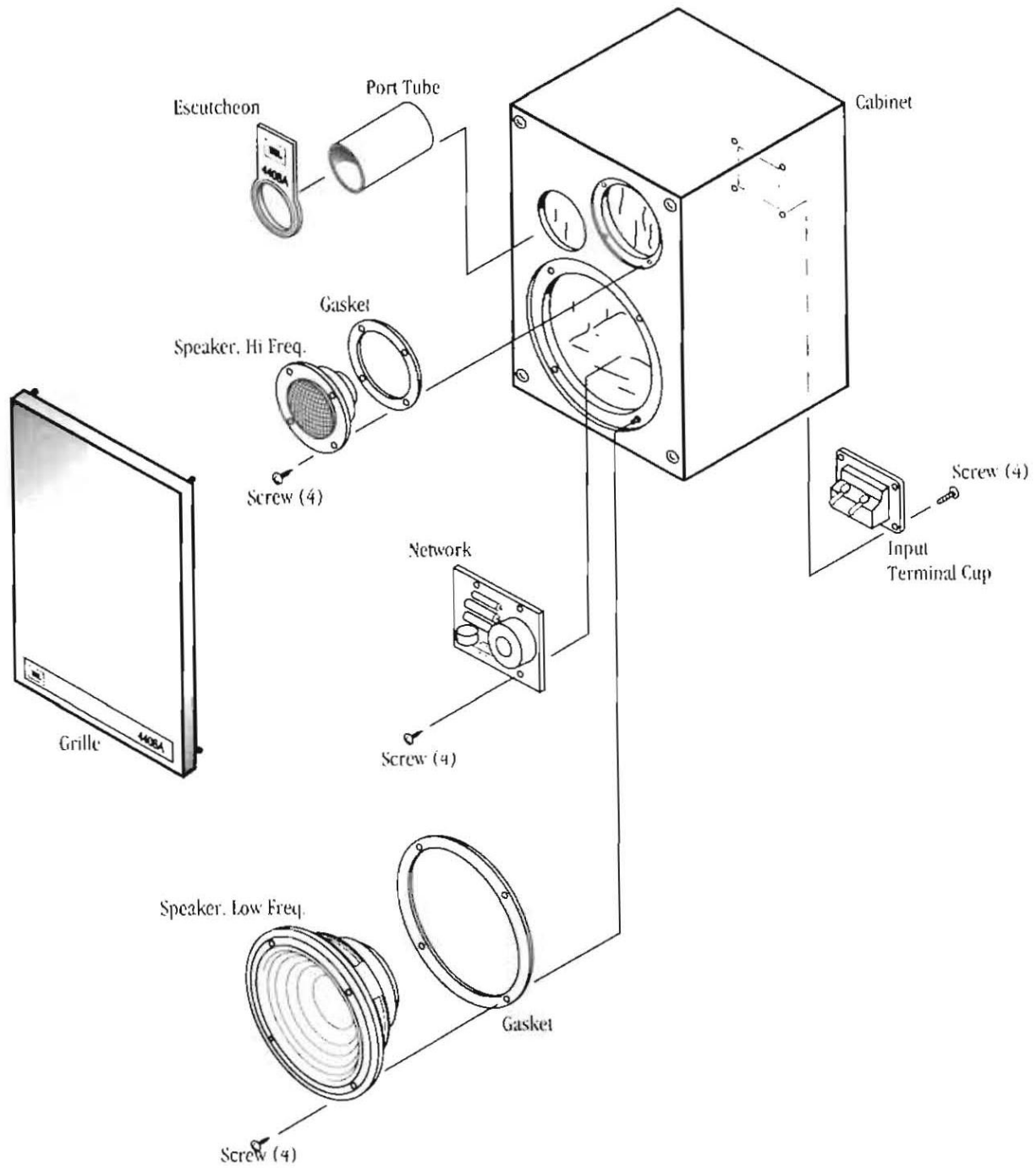



# 4410A

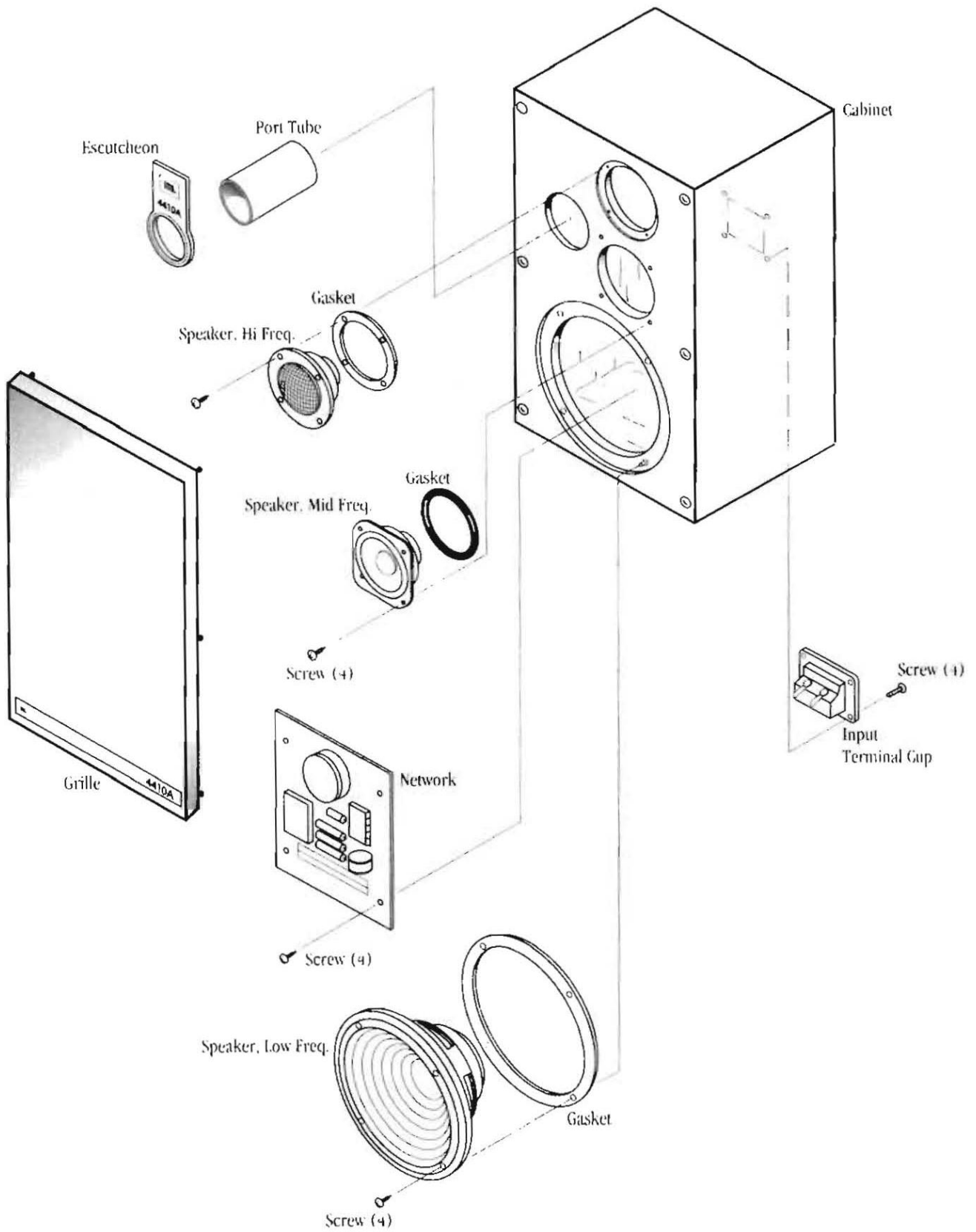

# 4412A

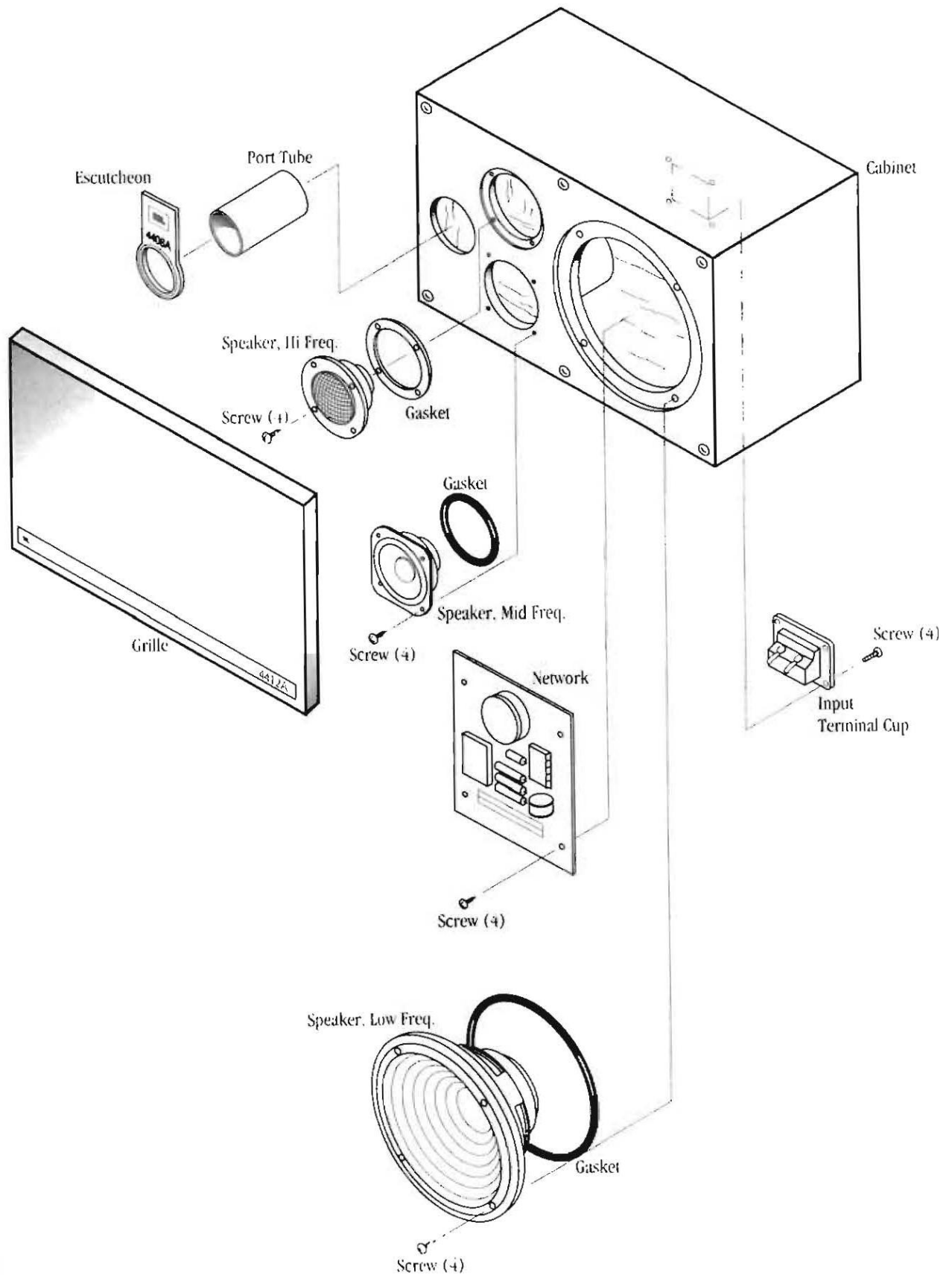

---

Should you experience a component failure, it is recommended that you take the defective system to the nearest authorized JBL Service Center for proper service. To obtain the name and location of the repair center nearest you, contact your local dealer/distributor or the factory at:

JBL Professional  
P.O. Box 2200  
8500 Balboa Blvd.  
Northridge, CA 91329 U.S.A.  
(818) 893-8411

---

## Component Removal

If there are no authorized service centers near you and your monitor(s) should require repair, it may be necessary to ship the defective component to the nearest repair center. In this event, it is highly recommended that the defective component be removed from the enclosure and shipped separately. This will prevent the possibility of freight damage to the enclosure.

*Removing the Low Frequency Transducer:* The LF transducer is mounted to the baffle with four screws. Before attempting to remove the LF transducer from the baffle, first lay the enclosure on its back. To gain access to the LF transducer, remove the grille by carefully pulling it away from the baffle. A tight fitting grille may require that you lift each corner a little bit at a time.

Remove the four screws which hold the component in place. The component should easily lift out of the baffle. Disconnect the leads from the terminals. Carefully package the component prior to shipping.

*Removing the Midrange and High Frequency Dome:* These transducers are held in place with four screws. It should be relatively easy to lift the transducers out of their place on the baffle once these screws are removed. However, sometimes the devices may appear glued in place and do not easily lift out. This can happen when painted surfaces are not completely dry and the pressure applied by the mounting screws causes a slight bonding of surfaces. With a steady hand, use a sharp edged tool (i.e. a knife) to lift the edge of the mounting flange away from the enclosure.

---

*Reconnecting Repaired or Replacement Components:* The crossover networks contained in 4400A Series monitors are designed with a specific color code to assure correct hook-up to the proper components. The color code is as follows:

Green = LF Positive (+)/Red

Green/Black = LF Negative (-)/Black

White = MF Positive (+)/Red

White/Black = MF Negative (-)/Black

Yellow = HF Positive (+)/Red

Yellow/Black = HF Negative (-)/Black



SYSTEM:	4408A	4410A	4412A
Frequency Range (-10 dB):	35 Hz - 30 kHz	33 Hz - 30 kHz	30 Hz - 30 kHz
Frequency Response ( $\pm 2$ dB):	50 Hz - 20 kHz	45 Hz - 20 kHz	45 Hz - 20 kHz
Power Rating:	100 watts, pink noise	125 watts, pink noise	150 watts, pink noise
Sensitivity:	89 dB SPL, 2.83 V @ 1 meter	90 dB SPL, 2.83 V @ 1 meter	89 dB SPL, 2.83 V @ 1 meter
Nominal Impedance:	8 ohms	8 ohms	8 ohms
Crossover Frequency:	2.5 kHz	900 Hz, 4.0 kHz	850 Hz, 4.0 kHz
Transducer Complement:	200 mm (8 in) LF Felted Cone 25 mm (1 in) HF Pure Titanium Dome	250 mm (10 in) LF Aquaplas 125 mm (5 in) Midrange Cone 25 mm (1 in) HF Pure Titanium Dome	300 mm (12 in) LF Aquaplas 125 mm (5 in) Midrange Cone 25 mm (1 in) HF Pure Titanium Dome
<b>GENERAL:</b>			
Finish:	Matte Gray Laminate	Matte Gray Laminate	Matte Gray Laminate
Grille Color:	Charcoal	Charcoal	Charcoal
Dimensions (H x W x D):	438 x 305 x 293 mm 17 1/4 x 12 x 11 5/8 in	597 x 362 x 286 mm 23 1/2 x 14 1/4 x 11 1/4 in	362 x 597 x 286 mm 14 1/4 x 23 1/2 x 11 1/4 in
Weight (each):	12 kg (26 lbs)	19 kg (43 lbs)	21 kg (47 lbs)
Shipping Weight (each):	13.6 kg (30 lbs)	23 kg (50 lbs)	24 kg (53 lbs)



JBL Professional  
8500 Balboa Blvd., Northridge, CA 91329 U.S.A  
**H** A Harman International Company

P/N 74840