

Technical Manual

JBL CONTROL 30/WH SPECIFICATIONS



ACOUSTIC & ELECTRICAL SPECIFICATIONS:

- Nominal Impedance: 4 ohms
- Power Capacity: 500W Continuous Program Power
250W Continuous Pink Noise
- Frequency Range: 38 Hz – 17 kHz (-10 dB)
- Sensitivity: 93 dB, 1 Watt @ 1 Meter (3.3ft)
- Crossover Frequencies: 450 Hz to 1.8 kHz

SYSTEM COMPONENTS:

- Cabinet: C30 Black Enclosure
C30 White Enclosure
350272-001, 351117-001 Wh
- Grille: 350272-001, 351117-001 Wh
- Low Frequency Transducer: 250mm (10 in.) Fiberglass/Kevlar® cone
- DC Resistance: 4.8 ohms ±10%
- Mid Frequency Transducer: 125mm (5 in.) Anodized Aluminum cone
- DC Resistance: 5.7 ohm ±10%

SYSTEM COMPONENTS: (CONT'D)

- High Frequency Transducer: 25mm (1 in.) Compression Driver
Pure Titanium Diaphragm
- DC Resistance: 3.9 ohms ±10%
- Crossover Network: 350261-001

AURAL SWEEP TEST SPECIFICATIONS:

- A. L.F. Aural Sweep Test: 5.0VRMS Input, 20 Hz to 2 kHz
- B. M.F. Aural Sweep Test: 4.0VRMS Input, 200 Hz to 10 kHz
- C. H.F. Aural Sweep Test: 2.0V Input, 500 Hz to 20 kHz

PHYSICAL SPECIFICATIONS:

- Enclosure Dimensions: 593mm x 372mm x 345mm D
(23.3 x 14.6 x 13.5 in.D.)
- Shipping Weight: 45 lbs. (23.3 kg.)

WARRANTY INFORMATION:

- Refer to Warranty Statement packed with each product.

PACKAGE

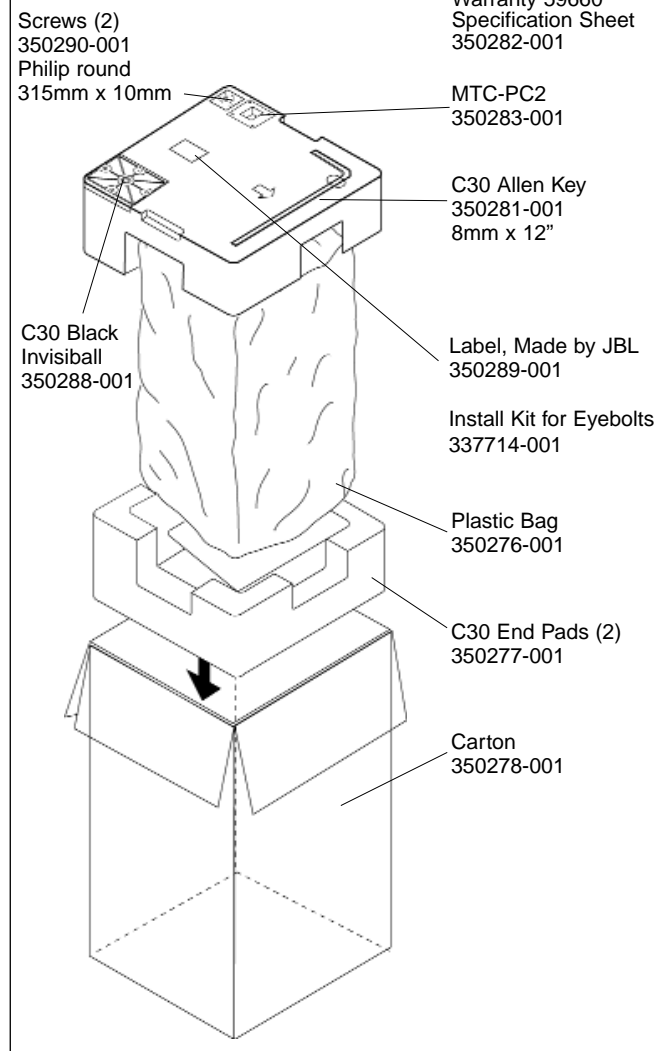

WIRING DIAGRAM

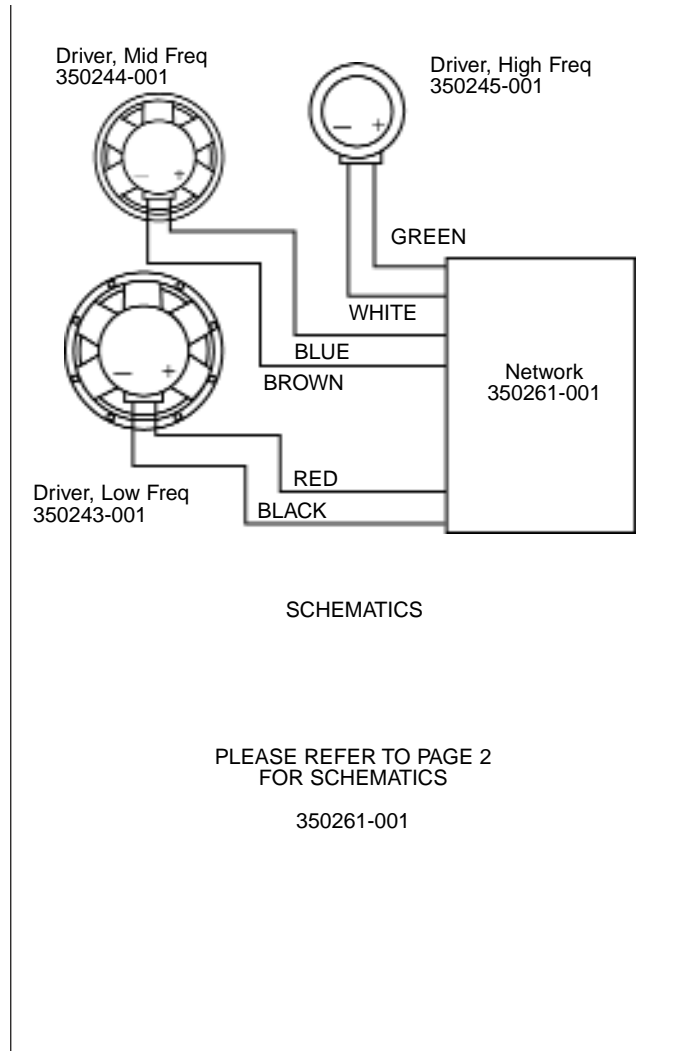

JBL CONTROL 30/WH

SCHEMATIC 350261-001 (old)

To Transformer Assy

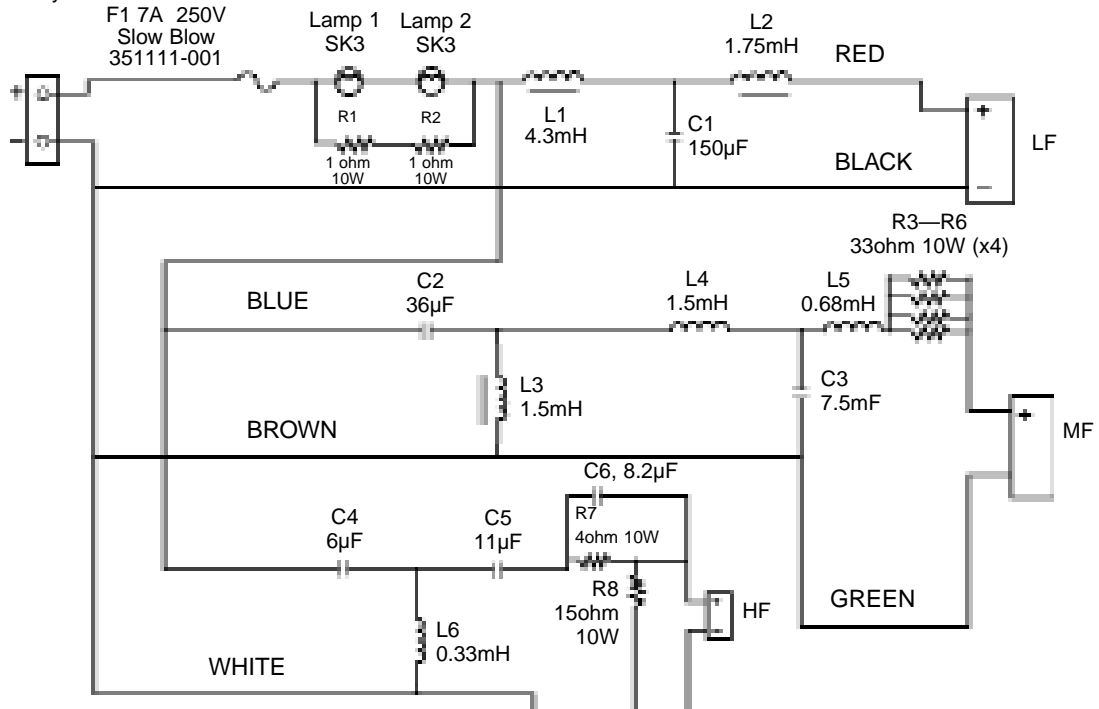

SCHEMATIC 350261-001 (new)

To Transformer Assy

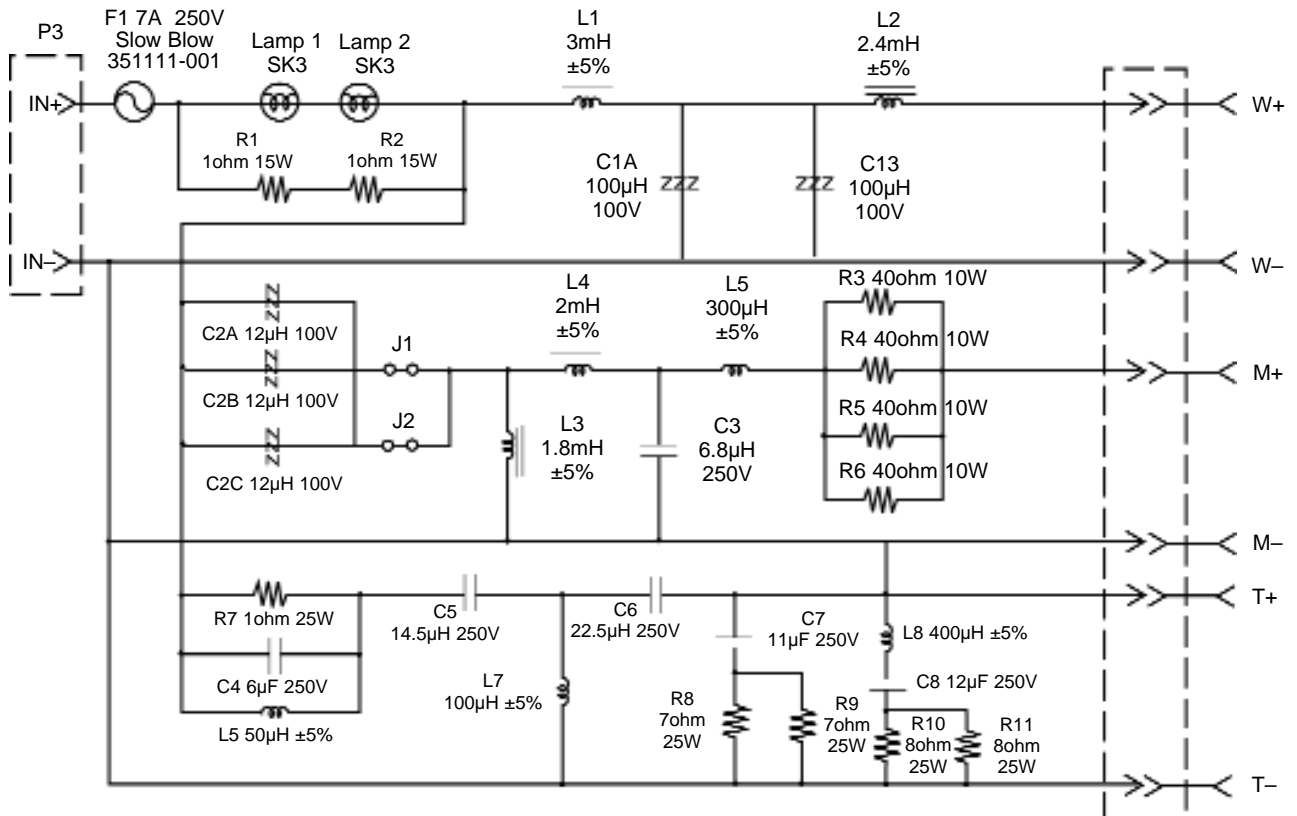

JBL CONTROL 30/WH

JBL CONTROL 30/WH

COMPONENT EXPLODED VIEW

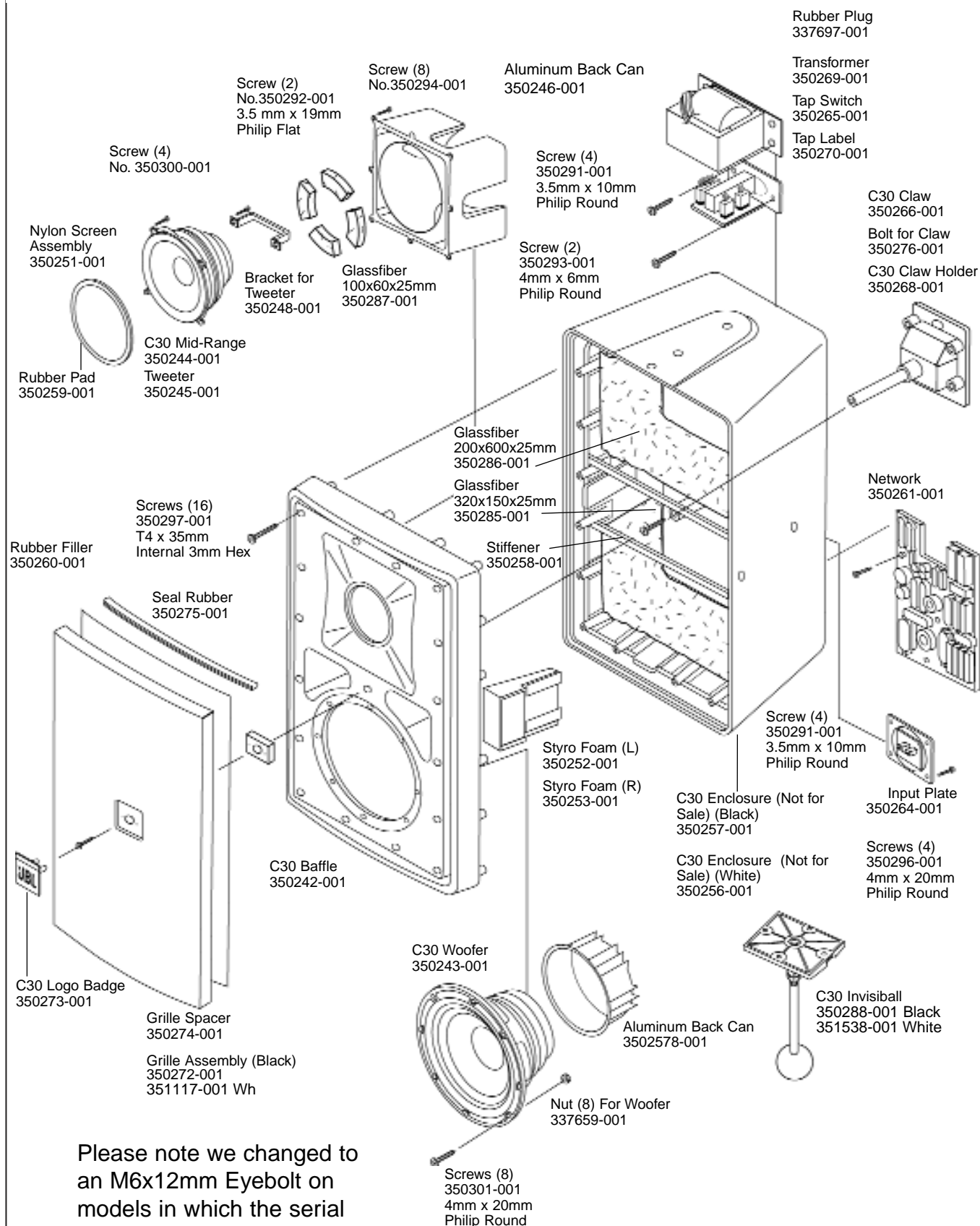

Please note we changed to an M6x12mm Eyebolt on models in which the serial numbers end with a -B Eyebolt, EB-6x12