

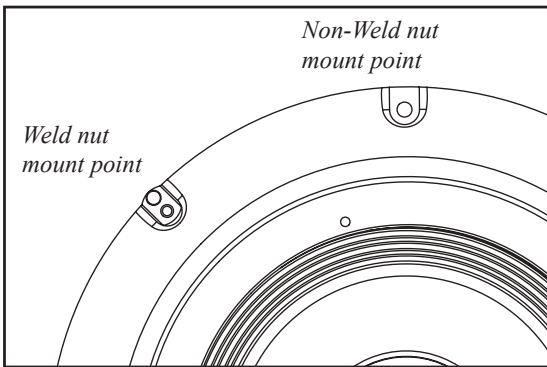

Control 328C/CT Backcan Assembly Instructions

1.) After inserting the Control 328C/CT into the back can, align the mounting holes without weld nuts to the holes with clip nuts on the back can. *These are the mounting points that will be used to secure the Control 328 baffle and driver to the backcan.*



2.) Using 4 pcs - #10 x .05 in (12mm) sheet metal screw, attaching the baffle / driver to the back can. Be sure to match the mounting holes without weld nuts to clip nuts on back can.

3.) Using 4 pcs - M4 x 38mm powder coated machine screws, attach the metal grille to the baffle. Be sure to match the grille mounting holes to the weld nuts on the baffle assembly.

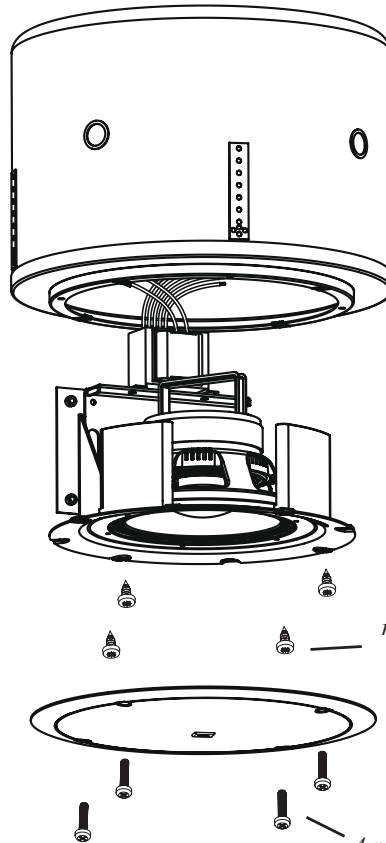

4 pcs - #10 x .05 in (12mm) sheet metal screw for attaching the baffle / driver to the back can. Match to clip nuts on back can. (Included with MTC-300BB8.)

4 pcs - M4 x 38mm powder coated machine screws for attaching the metal grille to the baffle. (Included with MTC-300RG8.)

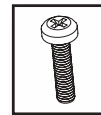

JBL Professional
8500 Balboa Boulevard, P.O. Box 2200
Northridge, California 91329 U.S.A.

■ A Harman International Company

363753-001
9/06