

EON[®]G2

GENERATION 2

EON Sub G2 User's Guide



Contents

JBL

PROFESSIONAL

Package Contents	4
Agency Approvals and Certifications	4
Before You Begin - Important Information	4
Mounting / Suspending EON Speakers	4
Care and Maintenance	4
Stand Mounting and Precautions	5
Electrical Safety	5
About The EON SUB G2	5
Applications	5
Features	5
Technical Specifications	6
Frequency Response.....	6
Available Accessories	6
Controls and Connections	7
Connectors	7
Switches and Controls.....	7
Indicators	7
Block Diagram	8
About Subwoofers	8
Application Examples	9
Stereo EON Mid / High System with EON Sub G2s	9
Mono Subwoofer	10
Powered Sub with Passive Mid / High	11
Voltage Selection And Fuses	12
Changing Voltage.....	12
Fuse Replacement.....	12
Troubleshooting	12
JBL Limited Warranty	14
JBL Professional Contact Information	15

Welcome

Welcome to the family of discerning sound equipment users who have selected JBL Professional loudspeakers. EON is a creation of JBL, the world leader in sound reinforcement. JBL sound systems are used in some of the world's most famous arenas, concert halls and clubs. In fact, JBL speakers are the premier choice for today's hottest touring acts and artists. You just can't make a more professional choice. This User Guide contains important information that will help you get the most from your JBL EON loudspeakers so please take a moment to read it and be sure to keep it in a safe place for future reference.

Congratulations and thanks from all of us at JBL Professional. You have invested in the best portable performance system available.

PACKAGE CONTENTS

Your EON Sub G2 should include the following:

- 1 User Guide
- 1 EON Sub G2 speaker
- 1 10' (3 m) IEC Power Cable

AGENCY APPROVALS AND CERTIFICATIONS

This EON G2 speaker complies with all International Safety Requirements for Mains Operated Professional audio equipment under IEC65, and Electromagnetic compatibility, Radio interference, Emissions and Immunity requirements.

BEFORE YOU BEGIN - IMPORTANT INFORMATION

Before using your EON Sub G2 speaker system please review the following for important information on safety and protection of your investment in quality loudspeakers.

Mounting / Suspending EON Speakers

EON speakers are designed for portable applications in which the speakers will be stacked directly on the floor, stage, speaker stands, or a solid, stable platform. Optional accessory items are available from JBL Professional and specific aftermarket suppliers to facilitate suspension and wall / ceiling mounting of EON speakers. Only those items recommended by JBL Professional should be used. When using these items, review all enclosed documentation and carefully follow all instructions and safety precautions.

CAUTION: Suspension of speakers should be done by qualified persons following safe rigging standards and practices. Unsafe mounting or overhead suspension of any heavy load can result in serious injury and equipment damage.

Care and Maintenance

While your EON speakers are rugged and will provide years of service, some common sense care in handling will prevent damage and preserve appearance.

- If your speakers will be frequently moved, consider a padded carrying bag (see AVAILABLE ACCESSORIES).
- If your EON speakers have been subjected to prolonged exposure to extreme low temperatures, avoid subjecting them to heavy mechanical shock and warm the speakers up by playing at a low volume for one hour before playing at loud levels.

- Keep the exterior of the speaker enclosure clean. Use a damp rag with a general-purpose household detergent. For grease and marking tape residue, use a damp cloth with isopropyl alcohol or mineral spirits and wipe dry. Do not use powerful solvents like acetone, MEK, lacquer thinner or 1,1,1-Trichloro-ethane (household cleaning fluid). These solvents will damage painted and co-polymer surfaces of your speakers.
- EON speakers are not intended for fixed installation in outdoor environments. Moisture can damage the speaker cone and surround, cause corrosion of electrical contacts, and create an electrical shock hazard. Protect your speakers from moisture. Avoid exposing the speakers to direct moisture. Any electrically powered device can produce dangerous shock hazards when wet or exposed to moisture. Keep speakers out of extended or intense direct sunlight. The driver suspension will prematurely dry out and finished surfaces will be degraded by long-term exposure to intense ultra-violet (UV) light.
- The EON Sub G2 contains no user serviceable parts. Refer servicing to an authorized JBL service agency.

Stand Mounting and Precautions

Your EON speakers include a 35mm receptacle cup to facilitate mounting on tripod stands. When using stands, be sure to observe the following precautions:

- EON speakers include a thumb-screw that can be tightened to lock the speaker to the tripod stand. Before mounting the speaker on the stand, be sure to loosen the screw so that it doesn't prevent the pole from fully penetrating the socket.
- Check the stand specification to be certain it is designed to support the weight of the speaker (see specifications). Observe all safety precautions specified by the stand manufacturer.
- Always verify that the stand is placed on a flat, level, and stable surface.
- Route cables so that performers, production crew, and audience will not trip over them and pull the speaker over.
- Be sure to fully extend the legs of tripod type stands.
- Position the stand so that the legs do not present a trip hazard.
- Do not attempt to place more than one speaker on a stand designed for a single speaker.
- Always be cautious in windy, outdoor conditions. It may be necessary to place additional weight (i.e. sandbags) on the base of the stand to improve stability.

The EON Sub G2 generates considerable energy. When placed on a slippery surface such as polished wood or linoleum, the EON Sub G2 may move due to its acoustical energy output. Precautions should be taken to assure that the speaker does not fall off a stage or table on which it is placed. One solution is to place the speaker on a rubber mat.

Electrical Safety

All EON powered series speakers are fitted with a detachable power cord (supplied) which connects to the AC mains on the back panel of the loudspeaker. The power cord has an IEC female connector on one end and a male mains connector on the other end. This cord is supplied to accommodate the different worldwide safety and electrical code requirements. If the power cord supplied with your EON product has a 3-pin type plug do not cut off or damage the grounding plug. Like any electrical appliance, your EON powered speakers should not be used in water or when wet.

About the EON SUB G2

Applications

To supplement or extend the low frequency output of powered and non-powered full-range speaker systems.

Features

- 15" Differential Drive™ low-frequency driver with dual neodymium magnet for high power handling, efficiency, and light weight.
- 250 watts actual power delivered to the drivers.
- Balanced loop-through output.
- Thermomaster™ Total Thermal Management System®. A single piece, cast-aluminum baffle integrates the woofer frame, horn, and amplifier heat-sink. Air movement in the finned ports dissipates heat – no internal or external cooling fans are required.
- Rugged, light weight, black co-polymer enclosure with cast aluminum baffle.
- Integral 35mm pole mount receptacle with securing thumb screw.
- Extended low-frequency performance. Delivers powerful bass down to 40 Hz.

Technical Specifications

Freq. Range (-10 dB)	40 Hz – 200 Hz
Crossover Freq.	125 Hz
Maximum SPL	117 dB, @ 1 m (3.3 ft)
Dimensions (H x W x D)	686 mm x 430 mm x 444 mm (27 in x 17 in x 17.5 in.)
Net Weight	19.5 kg (43 lbs.)
Driver	Integral frame with one 15" (380 mm) driver, dual neodymium magnet, 2" differential drive voice coil.

Electronic

Amplifier Rated Power	250 watts @ 2Ω, 0.1% THD
Input Type	Balanced, differential
Maximum Input Level	
Line Level In	+28 dBu
Speaker Level In	120 VRMS, speaker level
Input Impedance	
Line Level In	16 kΩ line level
Speaker Level In	143 kΩ speaker level
Audio Connectors	
Line Level In	XLR/F, balanced, line level
Speaker Level In	1/4" Phone, speaker level
Loop Output	XLR/M, balanced, line level
Low Pass Filter	125 Hz Active, 3-pole
AC Input	110 – 230 VAC, selectable, 50 – 60 Hz., 203 watts rating per UL, detachable IEC power cable.

Available Accessories

SS2-BK	Tripod Stand
ESK15	Suspension Kit for EON 15" models (except EON1500)
BRK15	Bracket, adapts EON 15" models to OmniMount® brackets
EON 15 WB	Zippered, plush-lined Cordura™ bag with wheels for EON15" models
EON 15 BAG	Zippered, plush-lined Cordura™ carrying bag for EON15" models

Controls and Connections

The audio section of the EON Sub G2 includes powerful features that enhance the flexibility of your subwoofer.

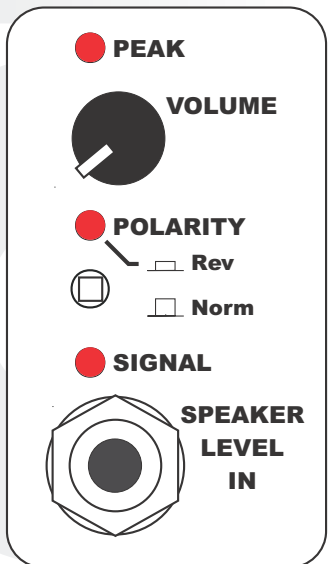
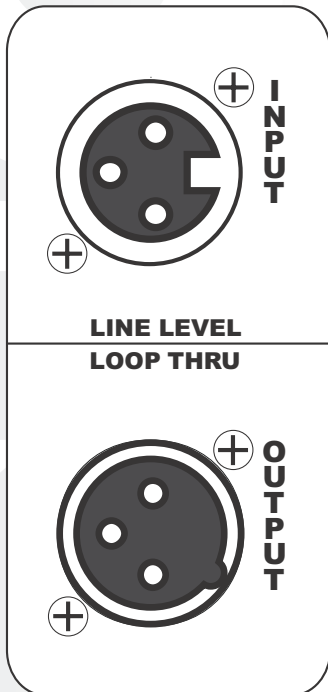

Connectors

LINE LEVEL INPUT

This balanced input accepts a standard XLR (female) connector. The LINE LEVEL INPUT is where the line level output of the audio mixer will be connected.

LOOP THRU OUTPUT

This XLR (male) connector is in parallel with the LINE LEVEL input and provides a convenient way to loop the audio signal from your mixer into additional EON Subs or your powered mid / high speakers.

SPEAKER LEVEL INPUT

This 1/4" phone jack accepts the high level output from a power amplifier or powered mixer. The SPEAKER LEVEL INPUT is the easiest way to add the EON Sub G2 to an existing system using a powered mixer or external amplifier to drive mid / high speakers. See "EON Sub G2 with Powered Mixer and Passive Mid / High System" for more details.

Switches and Controls

POLARITY

The performance of a subwoofer depends on how it interacts with the mid/high speaker system. Depending on characteristics of the mid/high system and the relative position of the subwoofer, changing this switch may improve system performance. Depress this switch to reverse the polarity of the subwoofer.

VOLUME

The VOLUME control adjusts the input sensitivity of the EON Sub G2.

Indicators

PEAK

This red LED illuminates to indicate that the amplifier output is approaching clipping.

POLARITY REV

This LED illuminates to indicate that the subwoofer is operating with reversed polarity. This means that a positive voltage on pin 2 of the LINE LEVEL INPUT will cause the speaker cone to move inward/backward.

SIGNAL

The SIGNAL LED illuminates to indicate that an audio signal is present at the LINE LEVEL INPUT or the SPEAKER LEVEL INPUT.

Block Diagram

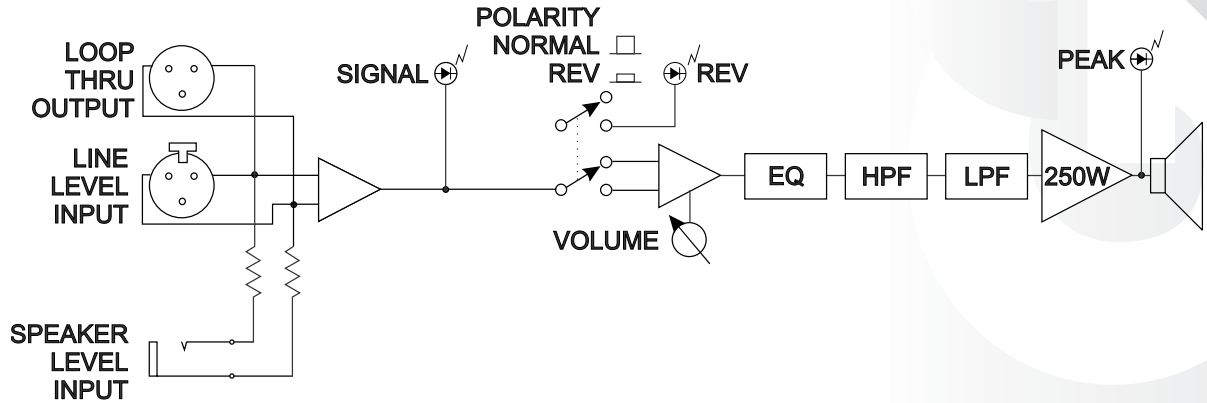

About Subwoofers

Here are a few bass basics. The ear is far less sensitive to very low frequencies than it is to mid-range frequencies. A 1,000 Hz sound at 95 dB SPL may seem obnoxious and painful to the ear while 50 Hz. at 95 dB SPL will seem pleasantly powerful. Musicians, composers, and producers know this instinctively and create music that contains a great deal of energy below 100 Hz. In order to properly produce or reproduce this music, an audio system needs to be capable of delivering much more acoustic output at low frequencies than in the mid band. Note that the capability of delivering more output should not be confused with the characteristic of low-frequency equalization boost. A system that is equalized to be perfectly flat may require as much as 20 dB more maximum SPL capability in the low bass. This is because the requirement for the extra energy is already built into the music. And contemporary dance music may rely even more on low frequencies for its power and energy.

To meet this need, speaker designers developed specialized speakers called subwoofers. Subwoofers are intended to work below 150 Hz. In fact, most subwoofers will sound downright bad if you try to use them to reproduce sound above 200 Hz. There are even sub-species of subwoofers. Some subwoofers are designed for extreme low-frequency extension and will go down as low as 20 Hz. This type of performance is usually more useful for cinema effects than for music. A sub that goes down this low will be very large and probably require a lot of amplifier power. Another variety of subwoofer that may be more appropriate and practical for portable music applications concentrates on delivering “punch”. Punch is what you experience when the kick drum hits you in the chest. Much of what we think of as punch is in the 80 Hz. region.

Until recently, adding a subwoofer to a system was a complicated matter that required external crossover networks, extra power amplifiers, and of course the subwoofer itself. The EON Sub G2 simplifies this task by combining all this into a single, simple and light weight system.

Application Examples

Stereo System With EON Mid / High System with EON Sub G2s

This is a system in which a pair of EON Subs are used with a pair of EON 2-way powered speakers.

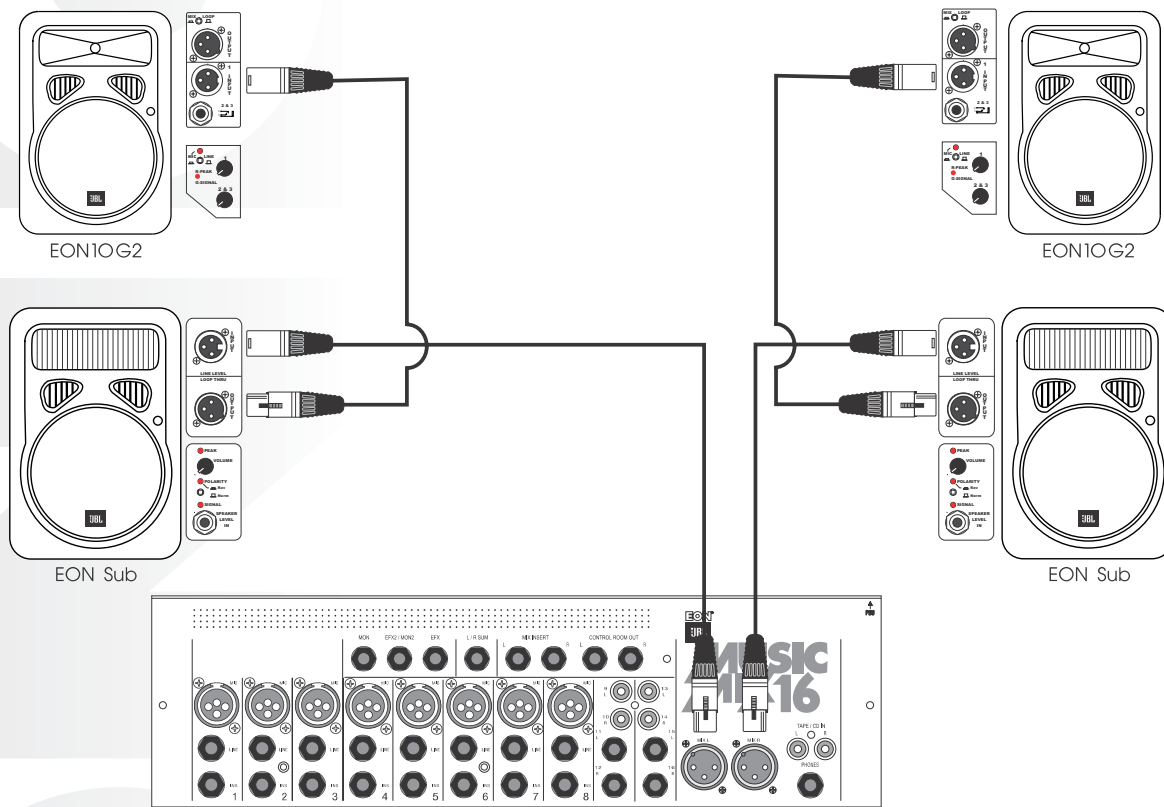

Mono Subwoofer

Here's a slightly more advanced set-up in which the subwoofers are not driven from the same mixer output as the 2-way main speakers. Using the subwoofers in mono will not degrade the stereo image because the ear does not do a good job of determining the source location of low frequency sound. The illustration shows two ways of using EON subs in mono. While two subwoofers are shown, you can also use this technique with a single subwoofer.

Driving the Subs from a Mono Output

Many mixers have a mono output that sums the left and right mix. The advantage of using this output to drive your subwoofers is that you will have separate control over subwoofer volume from the mixing console. This allows you to easily vary the balance between subwoofers and mid/high speakers.

Driving the Subs from an Auxiliary Output

Many professional engineers will create a separate mix for subwoofers from the Auxiliary buss of the mixer. This technique can improve low-frequency system performance in a number of ways. The system operator has independent control of the overall balance between subs and mid/highs and more flexibility in adjusting the blend of low frequency instruments. Let's say that you want to hear more lows from a bass guitar but don't want to hear more overall bass guitar. This method allows you to bring up the bass guitar in the subs without effecting the main mix.

Wind noise, handling noise, and bleed through of instrument amplifiers in a vocal mike can degrade the low-frequency sound. By using this technique, sources such as vocal mikes that don't have desirable low-frequency content can be kept out of the subs. Send only the instruments (kick drum, bass guitar, etc.) that actually have low-frequencies to your subs.

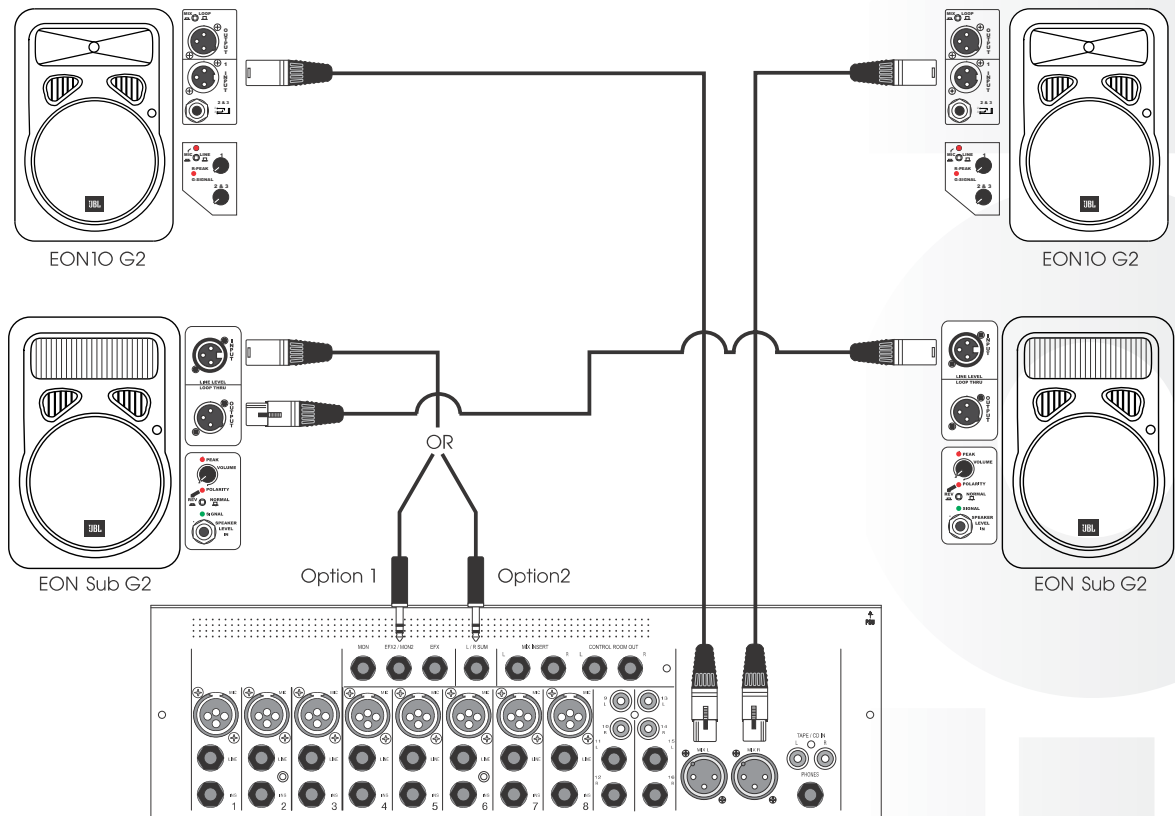

Powered Sub with Passive Mid / High

The SPEAKER LEVEL INPUT on your EON Sub G2 provides a simple and convenient way to add subwoofers to a system with passive 2-way speakers.

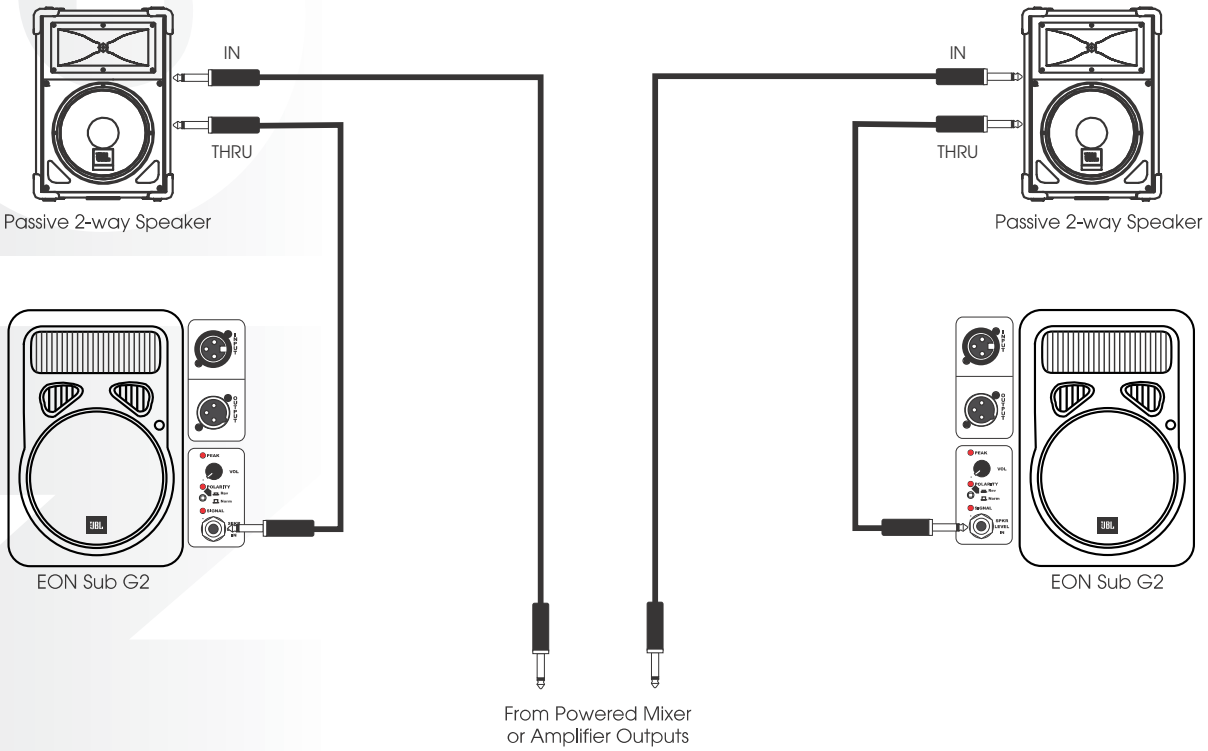

Voltage Selection And Fuses

Changing Voltage

Your EON Sub G2 will typically be set at the factory to accommodate the power mains voltage in your area. Before you set up your EON Sub G2 for the first time it is a good idea to verify that the setting of the selector is appropriate for the power in your area. Directly below the IEC power connector you will see a seal that indicates the factory setting for the voltage. If the voltage indicated is correct for your area, go ahead and power up your EON Sub G2.

In the event that you do need to change the voltage:

- Make sure that the AC is disconnected from the speaker.
- Directly below the male IEC connector on the speaker is a voltage selector. Break the factory-applied seal.
- Set the voltage selector switch to the 115V or 230V setting as required for your area.
- After having reconfirmed that the correct voltage is selected, connect the AC (IEC connector) and power the unit up.

DO NOT UNDER ANY CIRCUMSTANCES OPERATE THE UNIT WITH THE WRONG VOLTAGE SELECTED. DOING SO MAY RESULT IN SERIOUS DAMAGE TO YOUR SPEAKER SYSTEM WHICH WILL NOT BE COVERED BY WARRANTY.

Fuse Replacement

The EON Sub G2 has no user-serviceable fuses. Failure of fuses is most frequently a symptom of problems requiring service by a competent technician.

Troubleshooting

Symptom	Likely Cause	What to do
No sound	Speaker not connected to active AC power.	Verify that speaker is connected and that the circuit is on.
	Power not switched on.	Switch on power and verify that power LED is on.
No sound, speaker is connected to working AC power but won't come on.	Speaker power cable is faulty or improperly connected.	<ul style="list-style-type: none"> • Re-seat the power cable at both ends. • Substitute a known-good power cable.
	Blown fuse.	<ul style="list-style-type: none"> • There are no user-serviceable fuses in the EON SUB G2. Take your speaker to a competent servicer.
No sound. Speaker comes on. SIGNAL LED does not illuminate.	Signal source (mixer, instrument, etc.) is not sending.	<ul style="list-style-type: none"> • Check VU meters on the source mixer. • Verify that the tape or CD is playing. • Use headphones to verify that the instrument is actually sending an audio signal.
	Faulty cables and connections.	<ul style="list-style-type: none"> • Disconnect and re-seat signal cables. • Replace suspected cable with a known-good cable.
Signal sounds distorted and very loud, PEAK light is lit most of the time.	Excessive input signal, trying to exceed the capabilities of the speakers.	<ul style="list-style-type: none"> • Reduce the output level of the source. • Turn down the LEVEL controls on the speaker. • Use additional EON speakers.

Signal sounds distorted even at moderate volumes, PEAK light is not lit.	Mixer or other source is overdriven	Review the Owner's Manual for your mixer and adjust controls as needed <ul style="list-style-type: none"> • Input sensitivity (gain) • Channel faders • Master faders
Hum or Buzz that increases or decreases when the mixer level controls are moved.	Improper A/C ground or faulty equipment connected to mixer input	Disconnect or mute channels one at a time to isolate the problem. Refer to the owner's manual of the faulty equipment for troubleshooting help.
	Faulty cable between source equipment and mixer	Substitute a known-good cable for the suspected faulty cable.
Hum or Buzz	Improper A/C grounding, ground loops	<ul style="list-style-type: none"> • Connect all speakers to a common power circuit. • "Telescope" the audio ground by using an XLR/F to XLR/M adapter with Pin1 disconnected on one end. • Re-route audio cables away from AC power and lighting cables.
	Excessively long unbalanced cable run	<ul style="list-style-type: none"> • Use the balanced outputs (if available) of your mixer or source equipment to drive your EON speakers. • Use a "DI" (direct injection) box to convert your unbalanced equipment output to a balanced output.
	Improper system gain structure	Reduce the INPUT 1, LINE 2, and LINE 3 controls and increase the output level of your source devices.
Speakers feedback and howl when the microphone volume is turned up	Microphones are pointed into the speakers	Move the speakers so they do not point into the microphone's pick-up pattern.
	Equalizer settings are incorrect	Locate the feedback frequency and reduce it using the mixer EQ or an external equalizer.
	Excessive gain	Reduce the gain at the mixer and move the microphone closer to the sound source.

JBL Limited Warranty

The JBL Limited Warranty on professional sound products (except for loudspeaker enclosures) remains in effect for five years from the date of the first consumer purchase. JBL amplifiers are warranted for three years from the date of original purchase. Enclosures and all other JBL products are warranted for two years from the date of original purchase.

Who Is Protected by This Warranty?

Your JBL Warranty protects the original owner and all subsequent owners so long as: A.) Your JBL product has been purchased in the Continental United States, Hawaii or Alaska. (This Warranty does not apply to JBL products purchased elsewhere except for purchases by military outlets. Other purchasers should contact the local JBL distributor for warranty information.); and B.) The original dated bill of sale is presented whenever warranty service is required.

What is Covered by the JBL Warranty?

Except as specified below, your JBL Warranty covers all defects in material and workmanship. The following are not covered: Damage caused by accident, misuse, abuse, product modification or neglect; damage occurring during shipment; damage resulting from failure to follow instructions contained in your Instruction Manual; damage resulting from the performance of repairs by someone not authorized by JBL; claims based upon any misrepresentations by the seller; any JBL product on which the serial number has been defaced, modified or removed.

Who Pays for What?

JBL will pay all labor and material expenses for all repairs covered by this warranty. Please be sure to save the original shipping cartons because a charge will be made if replacement cartons are requested. Payment of shipping charges is discussed in the next section of this warranty.

How to Obtain Warranty Performance

If your JBL product ever needs service, write or telephone us at JBL Incorporated (Attn: Customer Service Department), 8500 Balboa Boulevard, PO. Box 2200, Northridge, California 91329 (818-893-8411). We may direct you to an authorized JBL Service Agency or ask you to send your unit to the factory for repair. Either way, you'll need to present the original bill of sale to establish the date of purchase. Please do not ship your JBL product to the factory without prior authorization. If transportation of your JBL product presents any unusual difficulties, please advise us and we may make special arrangements with you. Otherwise, you are responsible for transporting your product for repair or arranging for its transportation and for payment of any initial shipping charges. However, we will pay the return shipping charges if repairs are covered by the warranty.

Limitation of Implied Warranties

ALL IMPLIED WARRANTIES, INCLUDING WARRANTIES OF MERCHANTABILITY AND FITNESS FOR PARTICULAR PURPOSE, ARE LIMITED IN DURATION TO THE LENGTH OF THIS WARRANTY.

EXCLUSION OF CERTAIN DAMAGES

JBL'S LIABILITY IS LIMITED TO THE REPAIR OR REPLACEMENT, AT OUR OPTION, OF ANY DEFECTIVE PRODUCT AND SHALL NOT INCLUDE INCIDENTAL OR CONSEQUENTIAL DAMAGES OF ANY KIND. SOME STATES DO NOT ALLOW LIMITATIONS ON HOW LONG AN IMPLIED WARRANTY LASTS AND/OR DO NOT ALLOW THE EXCLUSION OF INCIDENTAL OR CONSEQUENTIAL DAMAGES, SO THE ABOVE LIMITATIONS AND EXCLUSIONS MAY NOT APPLY TO YOU. THIS WARRANTY GIVES YOU SPECIFIC LEGAL RIGHTS, AND YOU MAY ALSO HAVE OTHER RIGHTS WHICH VARY FROM STATE TO STATE.

JBL PROFESSIONAL CONTACT INFORMATION

Mailing Address



PROFESSIONAL

8500 Balboa Blvd.
Northridge California 91329

Customer Service

Monday through Friday 8:00am - 5:00pm Pacific Coast Time
In the U.S.A. (800) 8JBLPRO (800.852.5776)

On the World Wide Web

www.jblpro.com.

H A Harman International Company