



E SYSTEM 10

Complete
Portable Sound
Reinforcement System

Application:

The E-System 10, featuring two EON10 G2 powered speakers, a Soundcraft E6 sound reinforcement mixer, and two AKG D2000S dynamic hypercardioid microphones, is a complete, integrated sound system intended for a wide range of applications in reinforcement of music and speech.

Key Features:

The E-System 10 is just that—a system. From the top manufacturers in the pro audio industry, each component has been selected to support and complement the others.

EON G2 JBL EON10 G2 Speakers

The second generation of one of the most successful and influential professional speaker systems ever.

- ▶ 10" Differential Drive™ low-frequency driver with dual neodymium magnet for light weight and reduced distortion.
- ▶ 1" JBL compression driver with titanium diaphragm and ferro-fluid cooling.
- ▶ 125 watts low-frequency and 50 watts high-frequency (bi-amplified) - actual power delivered to the drivers.
- ▶ Three inputs. One balanced mic/line selectable input and one dual-channel, ¼" TRS phone line-level inputs.
- ▶ Balanced loop-through/mix output. "Daisy-chain" additional EON speakers or send the mixed output to a mixing console.
- ▶ 60° x 90° (nominal) constant directivity horn.
- ▶ Thermomaster® Total Thermal Management System®. A single piece, cast-aluminum baffle integrates the woofer frame, horn, and amplifier heat sink. Air movement in the finned ports dissipates heat - no internal or external cooling fans are required.
- ▶ Rugged, light-weight, black co-polymer enclosure.
- ▶ Integral 35 mm pole mount receptacle with securing thumb screw.
- ▶ Multi-angle enclosure for front of house or stage monitor application.

For more low-frequency power and performance, add the EONSUB G2 powered subwoofer or SoundFactor SF22SP powered subwoofer.



E6 Mixer

- ▶ 6 mic/line input channels
- ▶ 2 stereo input channels
- ▶ Three-band channel EQ with variable mid-frequency for precise tailoring of the sound
- ▶ Precision, ultra-linear mic pre-amps
- ▶ Two auxiliary monitor or effects busses with one pre/post selectable
- ▶ True professional +48V phantom power
- ▶ Smooth 100 mm faders for precise control of your mix
- ▶ Individual channel mute switches so you can mute an input without disturbing your mix
- ▶ Internal power supply
- ▶ Simple rack mounting options (available as an option)



D2000S Microphones

Rounding out the system is a pair of AKG D2000S handheld, dynamic hypercardioid microphones. These microphones have been selected to do a great job in a variety of applications from speech and vocals to instrument pick up.

► E-System 10 Complete Sound Reinforcement System

A complete sound reinforcement system so good that no one company could build it all. Start with the second generation of the speaker that started the powered-speaker revolution - the JBL EON10 G2. Then add a Soundcraft E6 mixer with that great British sound and wide range of features. To complete the system, a pair of dynamic, hypercardioid microphones from AKG - the D2000S. Rounding out the system are four 25 ft XLR cables to hook it all together.



JBL EON10 G2

Freq. Range (-10 dB)	65 Hz - 18 kHz
Freq. Response (± 3 dB)	90 Hz - 16 kHz
Horz. Coverage (-6 dB)	90° Nominal
Vert. Coverage (-6 dB)	60° Nominal
Rated Maximum SPL	117 dB, @ 1 m (3.3 ft)
Dimensions (H x W x D)	493 mm x 356 mm x 307 mm (19.4 in x 14.0 in x 12.1 in)
Net Weight	10.4 kg (23 lb)
LF Driver	Integral frame with one 10" (254 mm) driver, neodymium magnet, 1.5" Differential Drive voice coil.
HF Driver	JBL 2412 1" (throat diameter) compression driver with titanium diaphragm. Ferro-fluid cooled.
Amplifier Power LF	125 watts @ low-frequency driver impedance.
Amplifier Power HF	50 watts @ high-frequency driver impedance.
Input 1 Sensitivity	-48 dBu to 0 dBu for rated output (Mic/Line switch in MIC position) -6 dBu to +20 dBu for rated output (Mic/Line switch in LINE position)

Input 2 & 3 Sensitivity	-12 dBu to +20 dBu for rated output
Output Level	+26 dBu (peak), Loop/Mix switch in MIX position
Audio Connectors	
Input 1	XLR/F, balanced
Input 2 & 3	¼" Phone, dual-channel (TRS)
Loop/Mix Out	XLR/M, balanced
Active Crossover Freq.	2.7 kHz
AC Input	110 – 230 VAC, 50 – 60 Hz., 175 watts rating per UL, detachable IEC power cable.

EON10 G2 Block Diagram

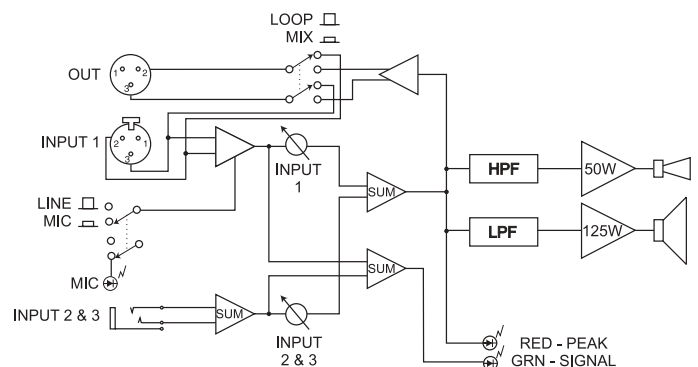



Soundcraft E6 Mixer

Input Channels	6 Mic/Line, mono 2 Line, stereo
Aux. Sends	2, globally selectable, pre/post
Noise (22 Hz-22 kHz measurement bandwidth)	
Mic EIN @ max gain, 150Ω source impedance	-128 dBu
Mix @ max, faders down	<-85 dBu
Crosstalk (typ. @ 1 kHz)	
Channel mute	>96 dB
Fader cut-off (rel +10 mark)	>96 dB
Aux send pot offness	>86 dB
Frequency Response	
Mic/Line input to any output	+/- 0.5 dB 20 Hz - 20 kHz
THD+ Noise	
Mic gain 30 dB, -30 dBu input	
Mix out, fader max @ 1 kHz	<0.007%
Input & Output Impedance	
Mic Input	2.4kΩ
Line Input	11kΩ
Stereo Input	100kΩ
Outputs	75Ω
Input & Output Levels	
Mic Input (max. level)	+17 dBu
Line Input (max. level)	>30 dBu
Stereo Input (max. level)	>30 dBu
Mix Input (max. level)	>20 dBu
Headphones (@200Ω)	300mW
Size	
Weight	5.75 kg (12.68 lb)
Dimensions (HxWxD)	87.58 mm x 375.60 mm x 400.10 mm (3.45 in x 14.79 in x 16.33 in)
Rack Mounting	Requires Soundcraft Part#P-520000D-01



AKG D2000S Microphone

Type	Dynamic microphone
Frequency Range	70 - 20,000 Hz
Polar Pattern	Hypercardioid
Sensitivity @ 1000 Hz	2.0 mV/Pa (-54 dBV re 1V/Pa)
Equivalent noise level	20 dB(A) to DIN 45412
Maximum SPL for 1% (3%) THD	140 dB SPL (150 dB SPL)
Electrical impedance	<500 ohms
Recommended load impedance	>1200 ohms
Connector	3-pin male XLR
Finish	Matte black enamel
Size	
Length :	181 mm (7.13 in)
Ø:	50 mm (1.97 in)
Weight	8.1 oz (0.9 lb)

System Contents

<u>Item</u>	<u>Qty</u>
JBL EON10 G2 Speakers	2
Soundcraft E6 Mixer	1
AKG D2000S Microphones	2
25 ft. (7.6m) XLR/M to XLR/F Cables	4
JBL EON10 G2 User Guide	1
Soundcraft E6 User Guide	1

► E-System 10 Complete Sound Reinforcement System

Soundcraft E6 Block Diagram

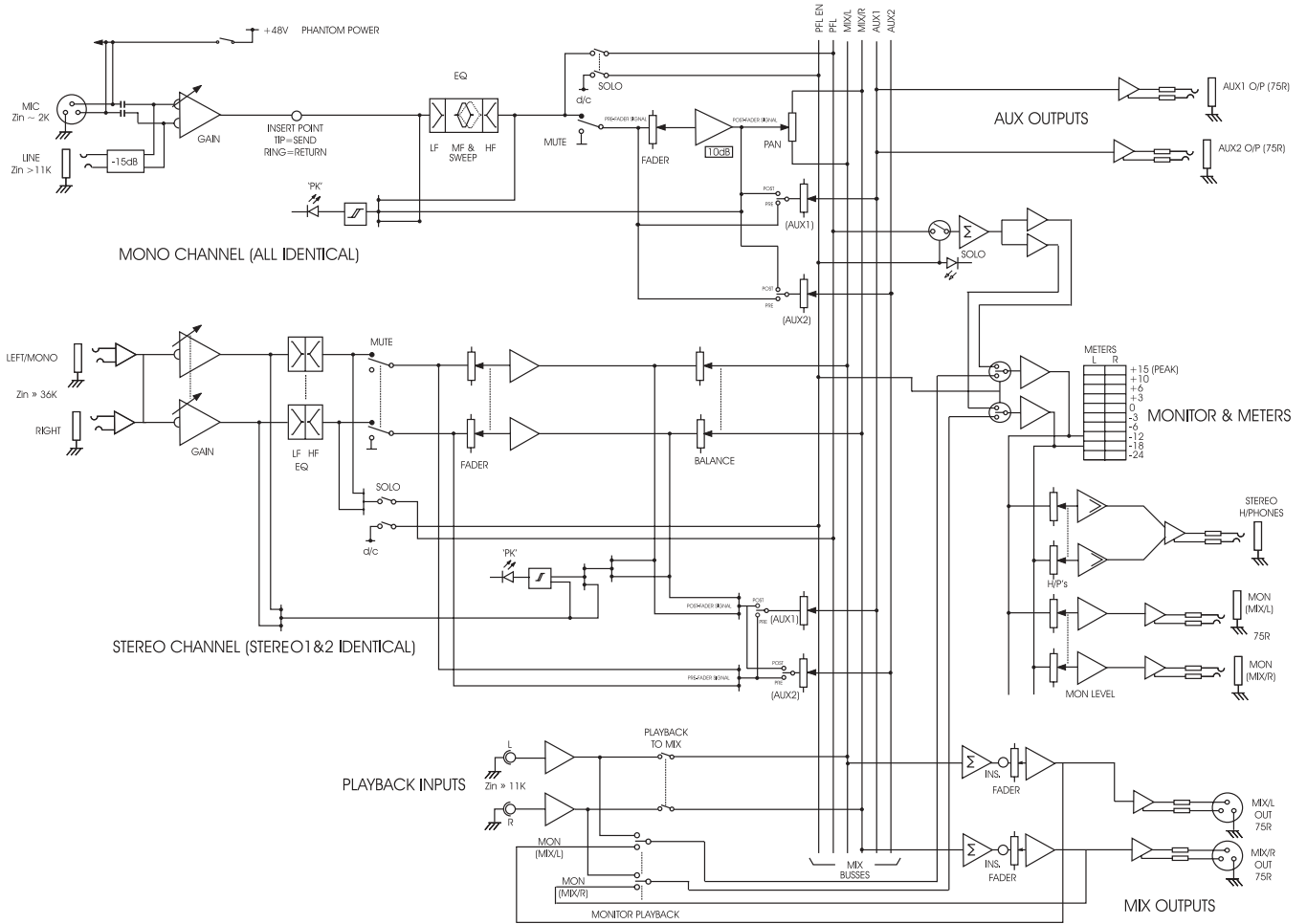

Available Accessories

- | | |
|-------------|---|
| SS2-BK | Tripod Speaker Stand |
| ESK10 | Suspension Kit for EON10" models |
| BRK10 | Bracket, adapts EON10" models to OmniMount® brackets |
| EON10 BAG-1 | Zippered, plush-lined speaker carrying bag for EON10 models |

We are constantly improving our products so these specifications are subject to change without notice.



JBL Professional
 8500 Balboa Boulevard, P.O. Box 2200
 Northridge, California 91329 U.S.A.
www.jblpro.com

■ A Harman International Company
 © Copyright 2003 JBL Professional

SSE-SYSTEM 10
 CRP 10M
 5/03