



E SYSTEM¹⁵

Complete
Portable Sound
Reinforcement System

Application:

The E-System 15, featuring two EON15 G2 powered speakers, a Soundcraft E8 sound reinforcement mixer, and two AKG D2000S dynamic hypercardioid microphones, is a complete, integrated sound system intended for a wide range of applications in reinforcement of music and speech.

Key Features:

The E-System 15 is just that—a system. From the top manufacturers in the pro audio industry, each component has been selected to support and complement the others.

EON^{G2} JBL EON15 G2 Speakers

The second generation of one of the most successful and influential professional speaker systems ever.

- ▶ 15" Differential Drive™ low-frequency driver with dual neodymium magnet for light weight and reduced distortion.
- ▶ 1" (throat diameter) JBL compression driver with 1.75" titanium diaphragm and ferro-fluid cooling.
- ▶ 300 watts low-frequency and 100 watts high-frequency (bi-amplified)—actual power delivered to the drivers.
- ▶ Built-in 3-input mixer. One balanced mic/line input, two balanced ¼" phone line-level inputs. Two-band equalization.
- ▶ Balanced loop-through/mix output. "Daisy-chain" additional EON speakers or send the mixed output to a mixing console.
- ▶ 60° x 90° (nominal) constant directivity horn.
- ▶ Thermomaster® Total Thermal Management System®. A single piece, cast-aluminum baffle integrates woofer frame, horn, and amplifier heat sink. Air movement in the finned ports dissipates heat—no internal or external cooling fans are required.
- ▶ Rugged, light-weight, black co-polymer enclosure.
- ▶ Integral 35 mm pole mount receptacle with securing thumb screw.
- ▶ Multi-angle enclosure for front of house or stage monitor application.
- ▶ Tailored dynamic processing protects amplifiers and speakers from being over-driven without producing extreme changes in frequency response as level varies.
- ▶ Extended low-frequency performance. Delivers powerful bass to below 40 Hz.



E8 Mixer

- ▶ 8 mic/line input channels
- ▶ 2 stereo input channels
- ▶ Three-band channel EQ with variable mid-frequency for precise tailoring of the sound
- ▶ Precision, ultra-linear mic pre-amps
- ▶ Two auxiliary monitor or effects busses with pre/post settings
- ▶ True professional +48V phantom power
- ▶ Smooth 100 mm faders for precise control of your mix
- ▶ Individual channel mute switches so you can mute an input without disturbing your mix
- ▶ Internal power supply
- ▶ Simple rack mounting options (sold separately)



D2000S Microphones

Rounding out the system is a pair of AKG D2000S handheld, dynamic hypercardioid microphones. These microphones have been selected to do a great job in a variety of applications from speech and vocals to instrument pick up.

► E-System 15 Complete Sound Reinforcement System

A complete sound reinforcement system so good that no one company could build it all. Start with the second generation of the speaker that started the powered-speaker revolution—the JBL EON15 G2. Then add a Soundcraft E8 mixer with that great British sound and wide range of features. To complete the system, a pair of dynamic, hypercardioid microphones from AKG—the D2000S. Rounding out the system are four 25 ft XLR cables to hook it all together.



JBL EON15 G2

Freq. Range (-10 dB)	39 Hz - 18 kHz
Freq. Response (± 3 dB)	42 Hz - 17 kHz
Horz. Coverage (-6 dB)	90° Nominal
Vert. Coverage (-6 dB)	60° Nominal
Rated Maximum SPL	129 dB, @ 1 m (3.3 ft)
Dimensions (H x W x D)	686 mm x 430 mm x 444 mm (27 in x 17 in x 17.5 in)
Net Weight	21 kg (46 lb)
LF Driver	Integral frame with one 15" (380 mm) driver, neodymium magnet, 2" Differential Drive voice coil.
HF Driver	JBL 2418H-1 1" (throat diameter) compression driver with 1.75" diameter titanium diaphragm. Ferro-fluid cooled.
Amplifier Power LF	300 watts @ low-frequency driver impedance.
Amplifier Power HF	100 watts @ high-frequency driver impedance.
Input 1 Sensitivity	-44 dBu to -22 dBu for rated output (Mic/Line switch in MIC position) -12 dBu to +20 dBu for rated output (Mic/Line switch in LINE position)
Input 2 & 3 Sensitivity	-18 dBu to +20 dBu for rated output
Output Level	+20 dBu (peak), Loop/Mix switch in MIX position
Output Level	+26 dBu (peak), Loop/Mix switch in MIX position

Audio Connectors

Input 1	XLR/F, balanced
Input 2 & 3	¼" Phone, balanced (TRS)
Loop/Mix Out	XLR/M, balanced

EQ

High Frequency Shelving, ± 15 dB @ 5 Hz
Low Frequency Shelving, ± 15 dB @ 120 Hz

Active Crossover Freq.

1.5 kHz

Limiting

Low frequency amplifier controlled by dynamic filter to prevent amplifier overload under extreme conditions.

AC Input

110 – 230 VAC, 50 – 60 Hz., 175 watts rating per UL, detachable IEC power cable.

EON15 G2 Block Diagram

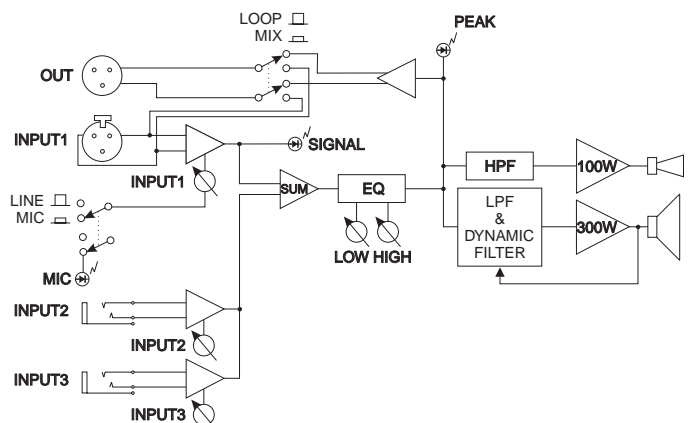



Soundcraft E8 Mixer

Input Channels	8 Mic/Line, mono 2 Line, stereo
Aux. Sends	2, globally selectable, pre/post
Noise (22 Hz-22 kHz measurement bandwidth)	
Mic EIN @ max gain, 150 Ω source impedance	-128 dBu
Mix @ max, faders down	<-85 dBu
Crosstalk (typ. @ 1 kHz)	
Channel mute	>96 dB
Fader cut-off (rel +10 mark)	>96 dB
Aux send pot offness	>86 dB
Frequency Response	
Mic/Line input to any output	+/- 0.5 dB 20 Hz - 20 kHz
THD+ Noise	
Mic gain 30 dB, -30 dBu input	
Mix out, fader max @ 1 kHz	<0.007%
Input & Output Impedance	
Mic Input	2.4k Ω
Line Input	11k Ω
Stereo Input	100k Ω
Outputs	75 Ω
Input & Output Levels	
Mic Input (max. level)	+17 dBu
Line Input (max. level)	>30 dBu
Stereo Input (max. level)	>30 dBu
Mix Input (max. level)	>20 dBu
Headphones (@200 Ω)	300mW
Size	
Weight	6.75 kg (14.88 lb)
Dimensions (HxWxD)	87.58 mm x 426.4 mm x 400.10 mm (3.45 in x 16.79 in x 16.33 in)
Rack Mounting	Requires Soundcraft Part#P-S20001D-01



AKG D2000S Microphone

Type	Dynamic microphone
Frequency Range	70 - 20,000 Hz
Polar Pattern	Hypercardioid
Sensitivity @ 1000 Hz	2.0 mV/Pa (-54 dBV re 1V/Pa)
Equivalent noise level	20 dB(A) to DIN 45412
Maximum SPL for 1% (3%) THD	140 dB SPL (150 dB SPL)
Electrical impedance	<500 ohms
Recommended load impedance	>1200 ohms
Connector	3-pin male XLR
Finish	Matte black enamel
Size	
Length :	181 mm (7.13 in)
Ø:	50 mm (1.97 in)
Weight	8.1 oz (0.9 lb)

System Contents

<u>Item</u>	<u>Qty</u>
JBL EON15 G2 Speakers	2
Soundcraft E8 Mixer	1
AKG D2000S Microphones	2
25 ft. (7.6m) XLR/M to XLR/F Cables	4
JBL EON15 G2 User Guide	1
Soundcraft E8 User Guide	1

► E-System 15 Complete Sound Reinforcement System

Soundcraft E8 Block Diagram

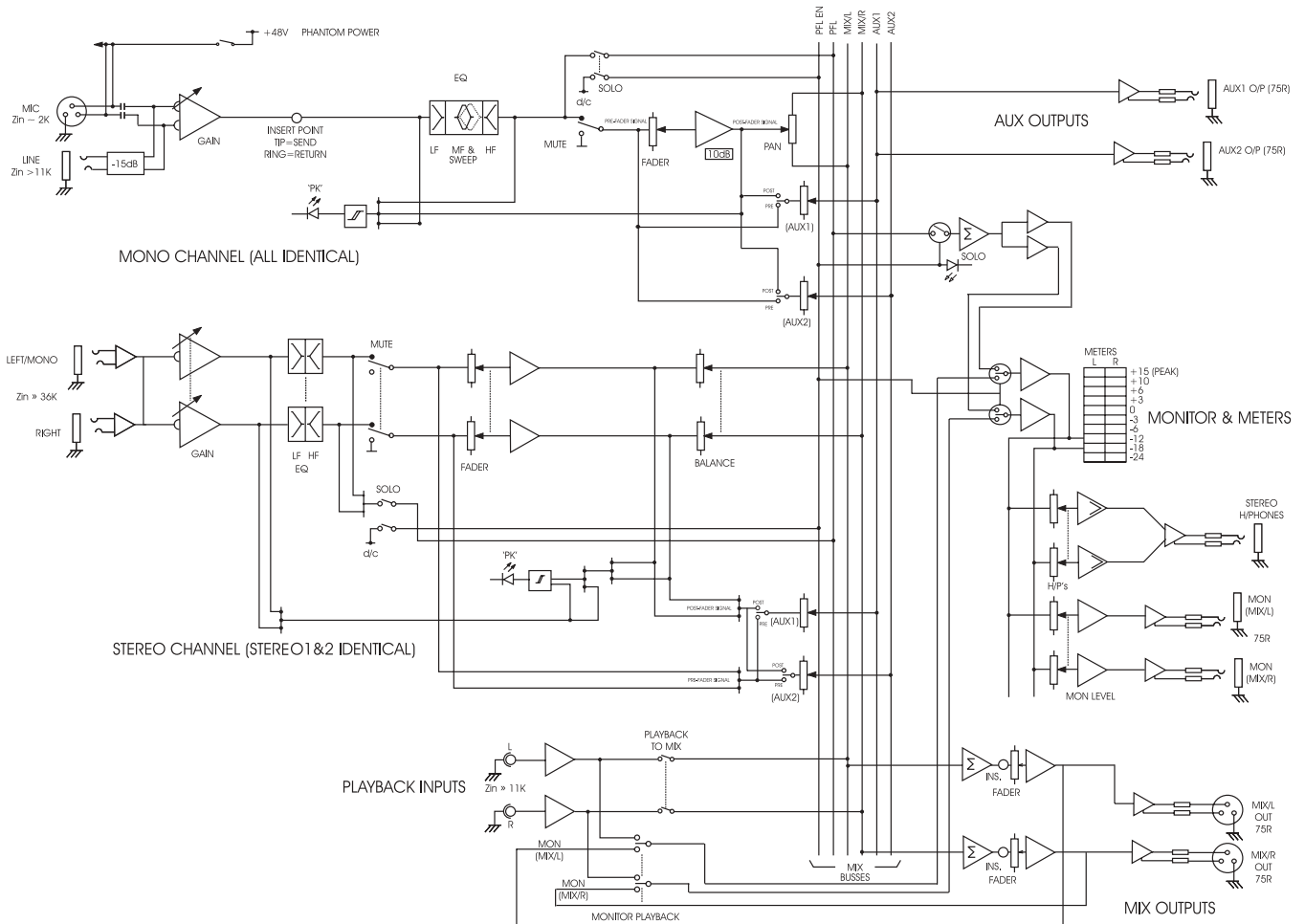

Available Accessories

- | | |
|---------------|--|
| SS2-BK | Tripod Speaker Stand |
| ESK15 | Suspension Kit for EON15" models (except EON1500) |
| BRK15 | Bracket, adapts EON15" models to OmniMount® brackets |
| EON15 BAG/N-1 | Zippered, plush-lined speaker carrying bag with wheels for EON15" models |
| EON15 BAG-1 | Zippered, plush-lined speaker carrying bag for EON15" models |

We are constantly improving our products so these specifications are subject to change without notice.



JBL Professional
8500 Balboa Boulevard, P.O. Box 2200
Northridge, California 91329 U.S.A.
www.jblpro.com

■ A Harman International Company
© Copyright 2003 JBL Professional

SSE-SYSTEM 15
CRP 10M
5/03