

Key Features:

- ▶ 40° by 30° Coverage Pattern – symmetrical frontal dimensions allow horizontal or vertical orientation within an array
- ▶ IFS™ Interference Free Summation dual HF driver module eliminates destructive interference and increases output by 6 dB
- ▶ Dual 8" horn loaded cone mid-frequency drivers provide 6 dB greater output than traditional designs
- ▶ Pattern control maintained to below 400 Hz
- ▶ Co-axial mid/high-frequency module layout improves mid-frequency arrayability and minimizes size
- ▶ Integrated rigging system simplifies array design and construction

The PD743 Precision Directivity™ loudspeaker provides high-impact sound reinforcement at throw distances that are beyond the reach of traditional single-driver designs. A single module produces greater than 104 dB SPL (continuous) at distances of 65 m (215 ft). The PD743 may be used in arrays with other PD series modules or singly as part of a distributed system. PD100 series low-frequency elements may be added to the array to extend bandwidth and pattern control to the lowest octaves.

The PD743 transducer complement features JBL's most advanced technology. The 2250J NDD™ Neodymium Differential Drive® 8" midrange transducer features a high energy neodymium magnet based motor, dual voice coils and a large aluminum heatsink structure. The 2430H compression driver utilizes the latest in magnet and diaphragm technology to pack the performance of a traditional 10.5 kg (23 lb), 25 cm (10 in) diameter compression driver into one weighing 1 kg (2.2 lb) and measuring 10.8 cm (4.25 in) in diameter.

For outdoor applications, several levels of weather resistance are available. Please contact your sales representative or JBL for further information.

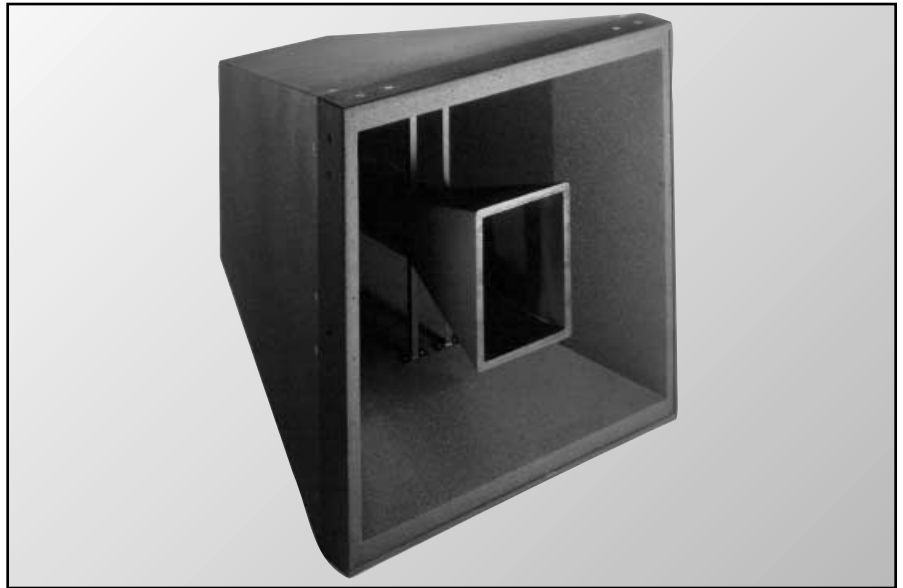

Preliminary Specifications:

System:

Frequency Range (-10 dB):	150 Hz - 17 kHz
Frequency Response (±3 dB):	200 Hz - 15 kHz
Hor. Coverage Angle (-6 dB):	40°
Vert. Coverage Angle (-6 dB):	30°
Directivity Factor (Q):	33
Directivity Index (DI):	15 dB
Recommended Crossover Frequencies:	225 Hz, 1.5 kHz
Nominal Impedance:	MF: 8 Ohms, HF: 16 Ohms
Input Power Rating ¹ :	MF: 700 W AES (2800 W peak) HF: 150 W AES (600 W peak)
Sensitivity ² :	MF: 111 dB, 1 W @ 1 m (3.3 ft) HF: 118 dB, 1 W @ 1 m (3.3 ft)
Calculated Maximum SPL:	MF: 139 dB Continuous; 145 dB Peak HF: 140 dB Continuous; 146 dB Peak SPL @ 1 m (3.3 ft)

Transducers:

Mid Frequency:	2 x 2250J - 203 mm (8 in) cone, Dual 75 mm (3 in) edge-wound ribbon voicecoil, NDD™ motor structure
High Frequency:	2 x 2430H - 75 mm (3 in) diaphragm, 38 mm (1.5 in) aperture, neodymium magnet

Physical:

Enclosure:	Dual Trapezoidal, 25° vertical, 35° horizontal; birch plywood
Suspension Attachment:	M10 threaded points, 24 total; 5 each top, bottom & sides, 4 rear
Finish:	Black DuraFlex™ coating (white & custom colors optional)
Grille:	Black powder coated zinc treated 14 gauge perforated steel with black foam backing (white & custom colors optional)
Input Connector:	Neutrik NL4 Speakon (Options: barrier strip or captive cable)
Dimensions (H x W x D):	39 in x 39 in x 45.1 in 991 mm x 991 mm x 1146 mm
Net Weight:	245 lb, 111.4 kg

¹ Rating based on AES test signal of filtered random noise with a peak-to-average ratio of 6 dB, two hours duration.

² Sensitivity is based on a swept test signal for an input of 1 Watt at rated impedance.

JBL continually engages in research related to product improvement. Some materials, production methods and design refinements are introduced into existing products without notice as a routine expression of that philosophy. For this reason, any current JBL product may differ in some respect from its published description, but will always equal or exceed the original design specifications unless otherwise stated.

► PD743 Very High Output Mid-High Loudspeaker System

Frequency Response

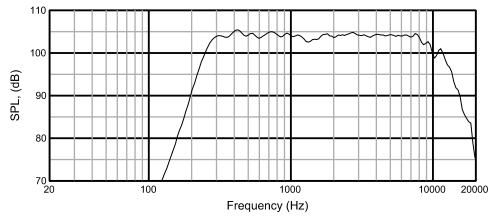

Horizontal Off Axis Frequency Response

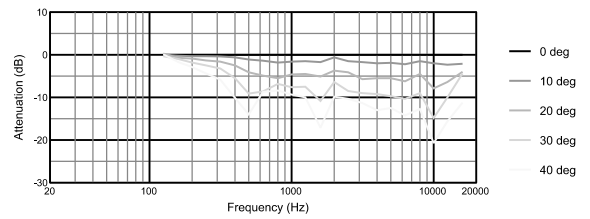

Beamwidth

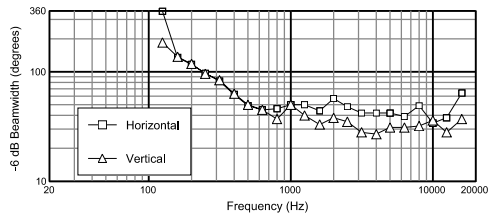

Vertical Off Axis Frequency Response

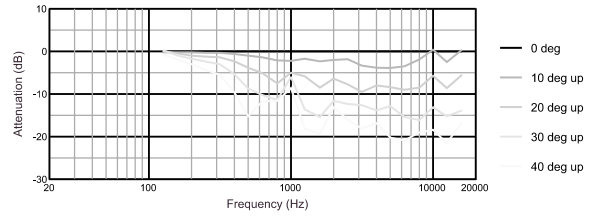

Directivity Index, Q

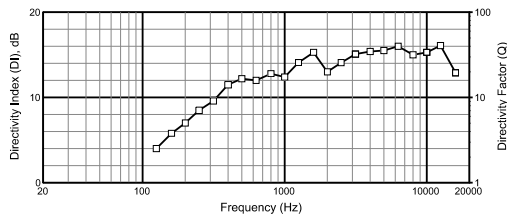

Dimensions

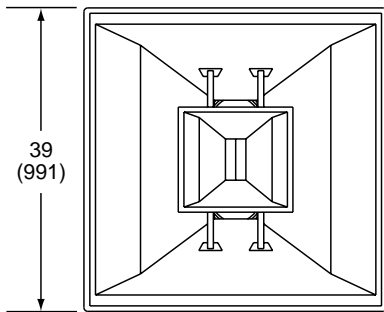

Front

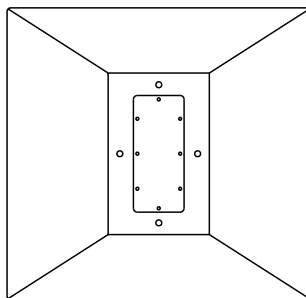
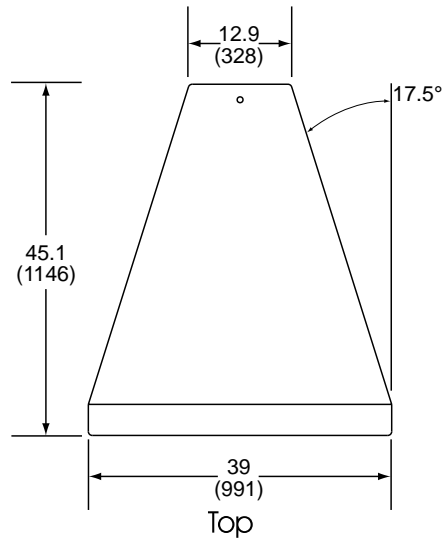

Rear

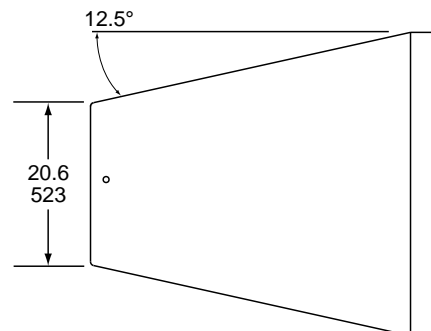

Sides

Dimensions in inches (mm)

Horizontal 1/3 Octave Polars

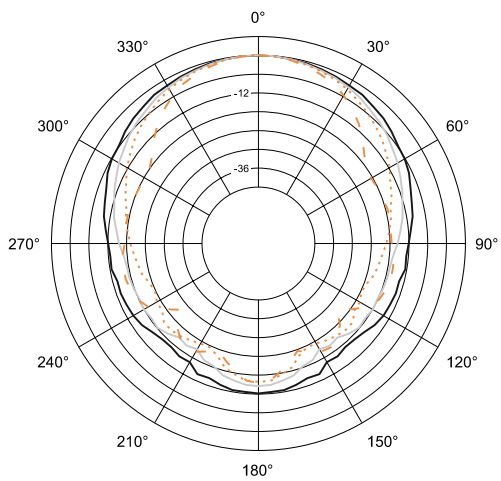

- 200Hz
- 250Hz
- ⋯ 315Hz
- - 400Hz

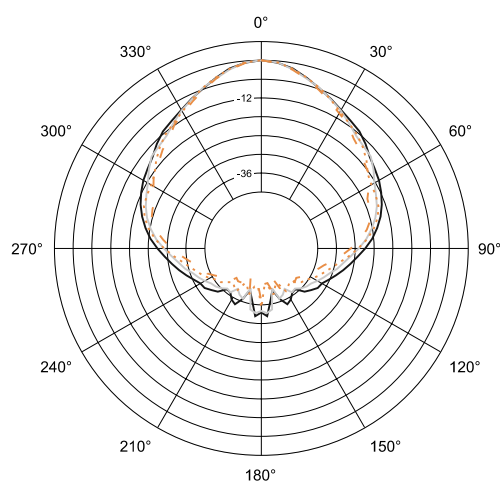

- 3.15kHz
- 4kHz
- ⋯ 5kHz
- - 6.3kHz

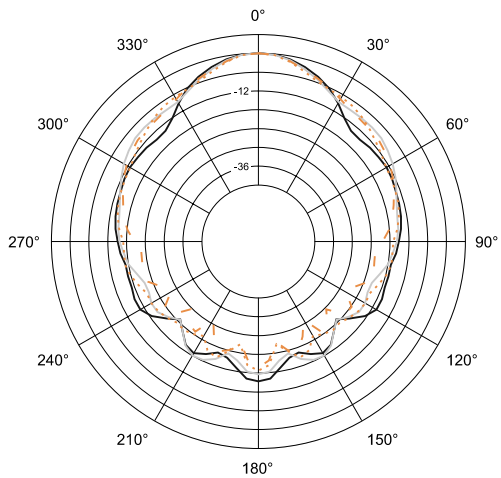

- 500Hz
- 630Hz
- ⋯ 800Hz
- - 1kHz

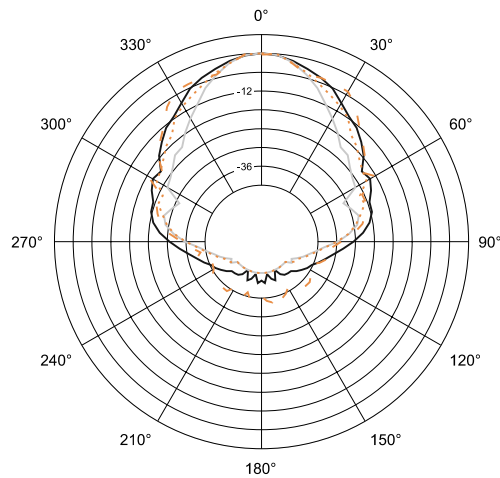

- 8kHz
- 10kHz
- ⋯ 12.5kHz
- - 16kHz

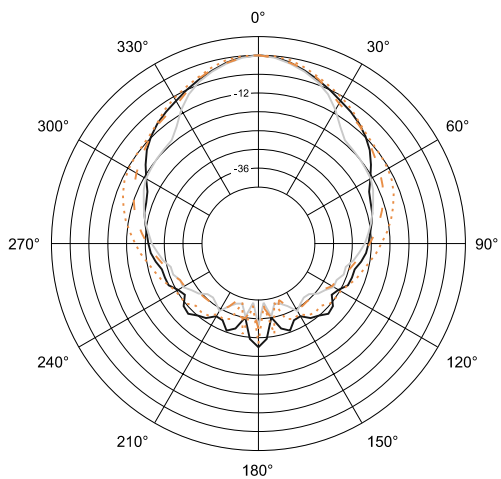

- 1.25kHz
- 1.6kHz
- ⋯ 2kHz
- - 2.5kHz

► PD743 Very High Output Mid-High Loudspeaker System

Vertical 1/3 Octave Polars

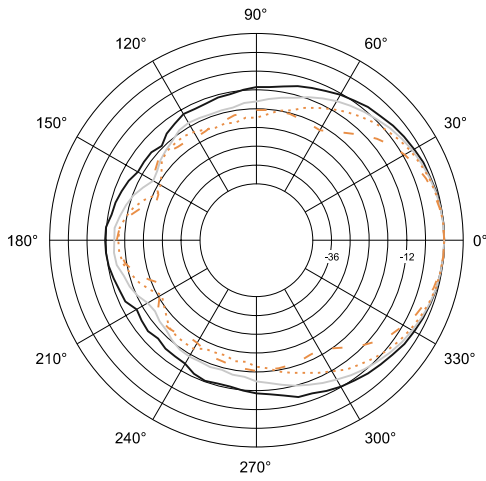

- 200Hz
- 250Hz
- ⋯ 315Hz
- - 400Hz

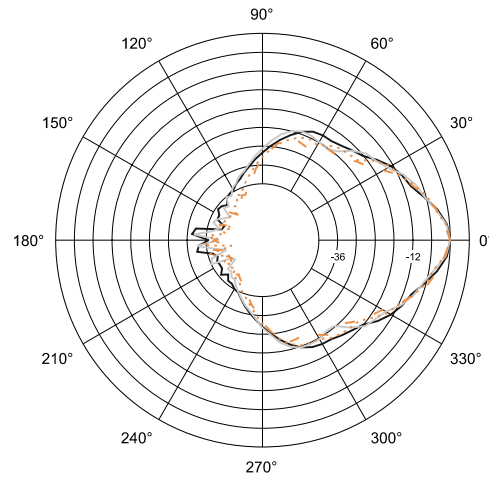

- 3.15kHz
- 4kHz
- ⋯ 5kHz
- - 6.3kHz

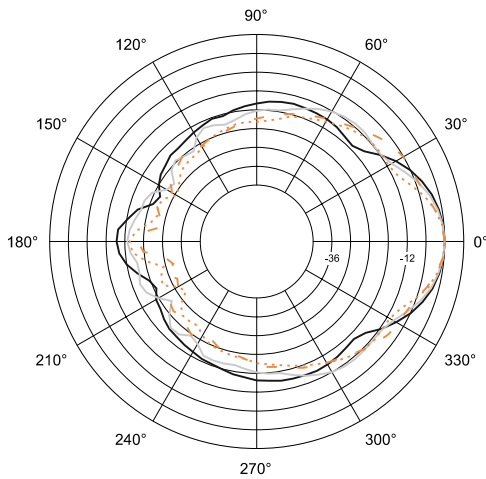

- 500Hz
- 630Hz
- ⋯ 800Hz
- - 1kHz

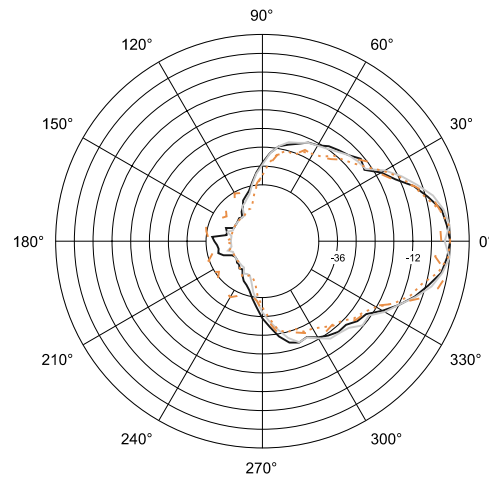

- 8kHz
- 10kHz
- ⋯ 12.5kHz
- - 16kHz

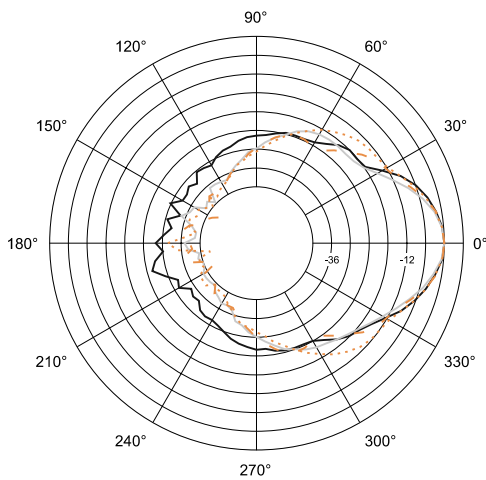

- 1.25kHz
- 1.6kHz
- ⋯ 2kHz
- - 2.5kHz



JBL Professional
 8500 Balboa Boulevard, P.O. Box 2200
 Northridge, California 91329 U.S.A.

■ A Harman International Company
 © Copyright 2000 JBL Professional

SS PD743
 CRP 15M
 8/01