

Technical Manual

JBL VT4889-1

SPECIFICATIONS



ACOUSTIC & ELECTRICAL SPECIFICATIONS:

- Systems Input Power Rating: LF: 2000 W Continuous, 8000 W Peak (AES / 2 hour)
MF: 1400 W Continuous, 5600 W Peak (AES / 2 hour)
HF: 225 W Continuous, 900 W Peak (AES / 2 hour)
- Frequency Response: 45 Hz -16 kHz (+/-3 dB)
- Frequency Range: 40 Hz - 18 kHz
- Max Peak Output: 136 dB to 146 dB SPL, 1m (Frequency/Bandpass Dependent)
- Recommended Signal: dbx® 4800, Crown® I-Tech, BSS FDS-366T, and other Digital System Controllers supported
- Recommended Amplification: LF: 2 x 1000 - 2000 W into ohms (2 x LF transducers powered independent)
- Horiz Coverage Angle: 90 degrees nominal, (250 Hz -16 kHz) (-6 dB)
- Vert Coverage Angle: Varies with array size and configuration (-6 dB)

SYSTEMS COMPONENTS:

- Cabinet: Enclosure Assembly C4889-1
- Grille: Grille, Left (351685-002)
Grille, Right (351685-001)
- Low Frequency Transducer: (2) 2255HPL, 380 mm (15 in.) 76 mm (3 in.) dual coil Neodymium Drive®, Direct Cooled™
- Bandpass Nominal Impedance (each driver): 8 ohms, Wired Individually
- Input Power Rating: (each driver) 2 x 1000 W Continuous, 2 x 4000 W Peak (AES / 2 hour), 2 x 650 W Continuous, 2 x 2600 W Peak (100 hour)
- Bandpass Sensitivity: 99 dB, 1W / 1m (2.83 Vrms at 3.3 ft)
- DC Resistance: 5.2 ohm ±10%
- Mid Frequency Transducers: (4) 2250HPL, 203 mm (8 in) dia. 76mm dual coil, Neodymium Differential Drive®, Direct Cooled™

SYSTEM COMPONENTS: (CONT'D)

- Bandpass Nominal Impedance: 8 ohms, Wired in Series Parallel
- Input Power Rating: 1400 W Continuous, 5600 W Peak (AES / 2 hour), 1200 W Continuous, 4800 W Peak (100 hour)
- Bandpass Sensitivity: 102 dB, 1W / 1m (2.83 Vrms at 3.3 ft)
- DC Resistance: 5.2 ohm ±10%
- High Frequency Transducer: (3) 2435HPL, 76 mm (3 in.) dia. beryllium diaphragm, 38 mm (1.5) throat diameter Neodymium compression drivers
- Bandpass Nominal Impedance: 16 ohm, Wired in Series
- Input Power Rating: (each driver) 225 W Continuous, 900 W Peak (AES / 2 hour)
- Bandpass Sensitivity: 116 dB, 1W / 1m (2.83 Vrms at 3.3 ft.)
- DC Resistance: 4.0 ohm ±10%
- Input Connectors: Neutrik Speakon NL-8 (2) Pins 1+/- & for Lows, Pin 3+/- for Mids, Pin 4+/- for Highs

AURAL SWEEP TEST SPECIFICATIONS:

- A. L.F. Aural Sweep Test: 10.0V Input, 20 Hz to 200 Hz
- B. M.F. Aural Sweep Test: 7.0V Input, 100 Hz to 1 kHz
- C. H.F. Aural Sweep Test: 0.75V Input, 1 kHz to 16 kHz

PHYSICAL SPECIFICATIONS:

- Enclosure Dimensions: 489 mm x 1213 mm x 546 mm D (19.25 x 47.75 x 21.0 in. D)
- Net Weight: 176 lbs. (79.8 kg)

WARRANTY INFORMATION:

- Refer to Warranty Statement packed with each product.

PACKAGE

Specification Sheet
363668-001

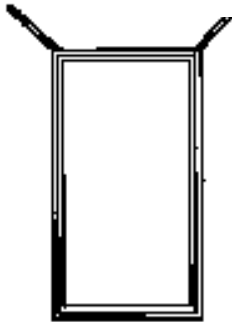

Soft Cover
363914-001

Carton
364187-001

Filler, Inner (2)
364188-001

Filler, Outer (2)
364189-001

Microfoam, (8)
49790P

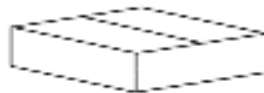

JBL VT4889-AF

Carton
990-00233-00

Filler (2)
991-00258-00

Specification Sheet
336890-001

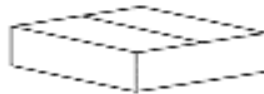

JBL VT4889-SF

Carton
990-00232-00

Filler (2)
337616-001

Specification Sheet
336890-001

910-00035-01 (1)
Ferro fluid vial w/
blotter paper and
instruction sheet

910-00035-02 (12)
Ferro fluid vials w/
blotter paper and
instruction sheet

JBL VT4889-1 REV L

JBL VT4889-1

WIRING DIAGRAM

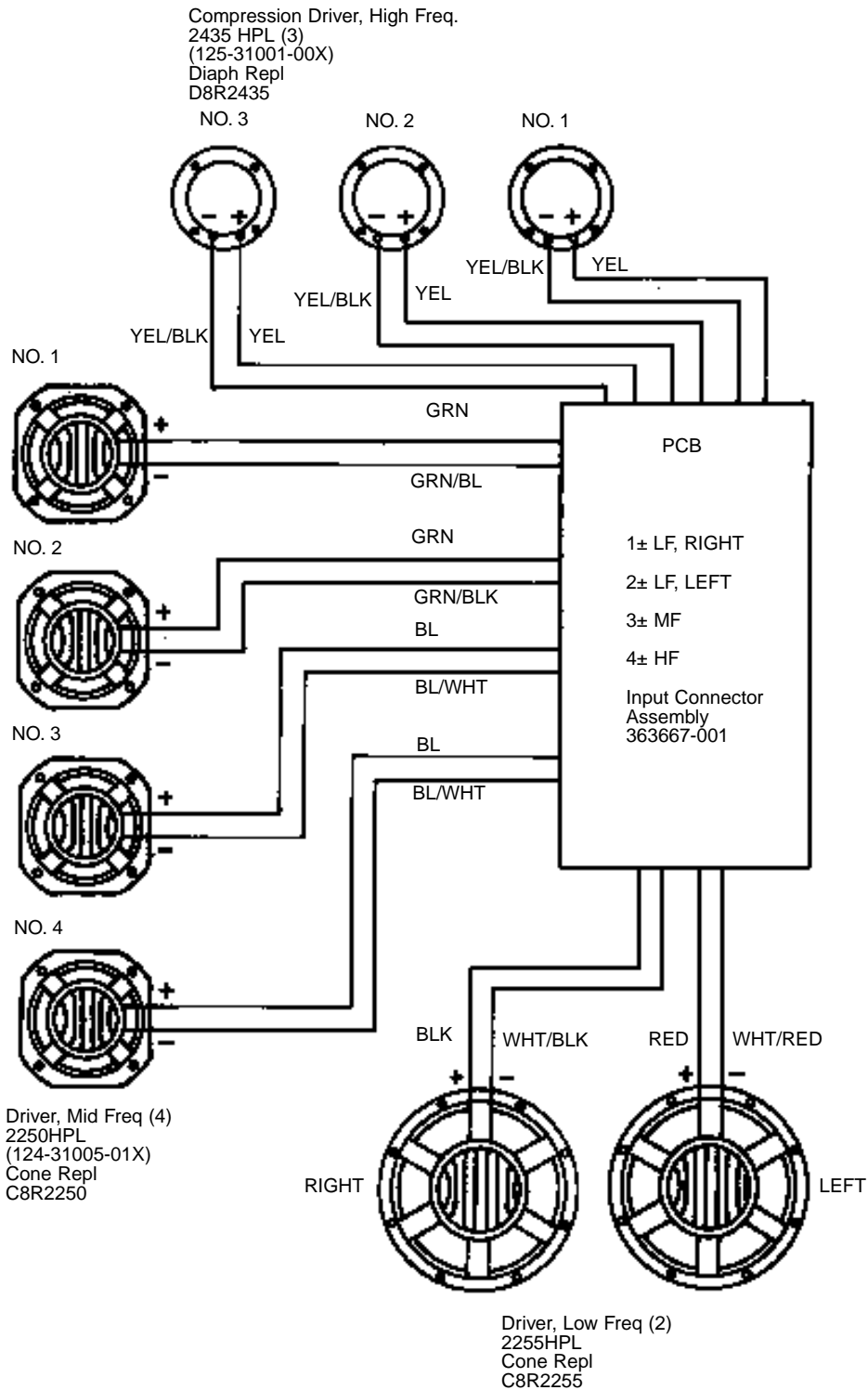

JBL VT4889-1

SCHEMATIC DIAGRAMS

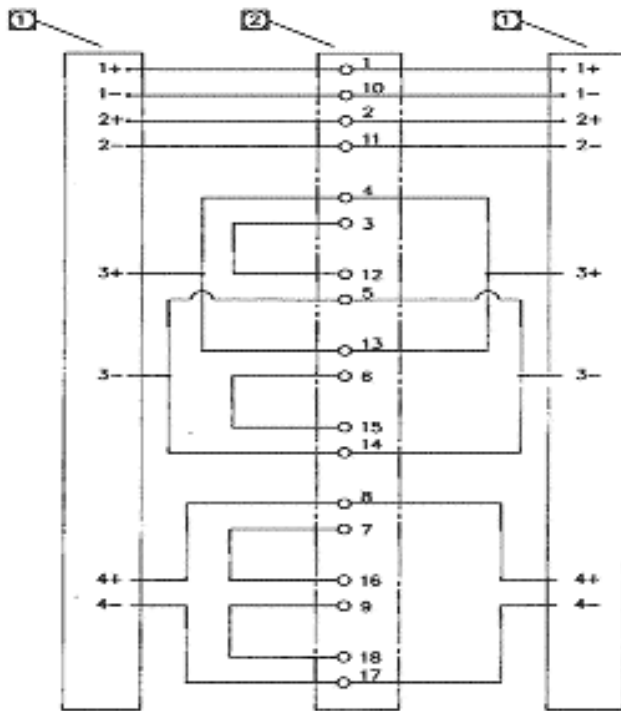

Connector Assembly
350971-001

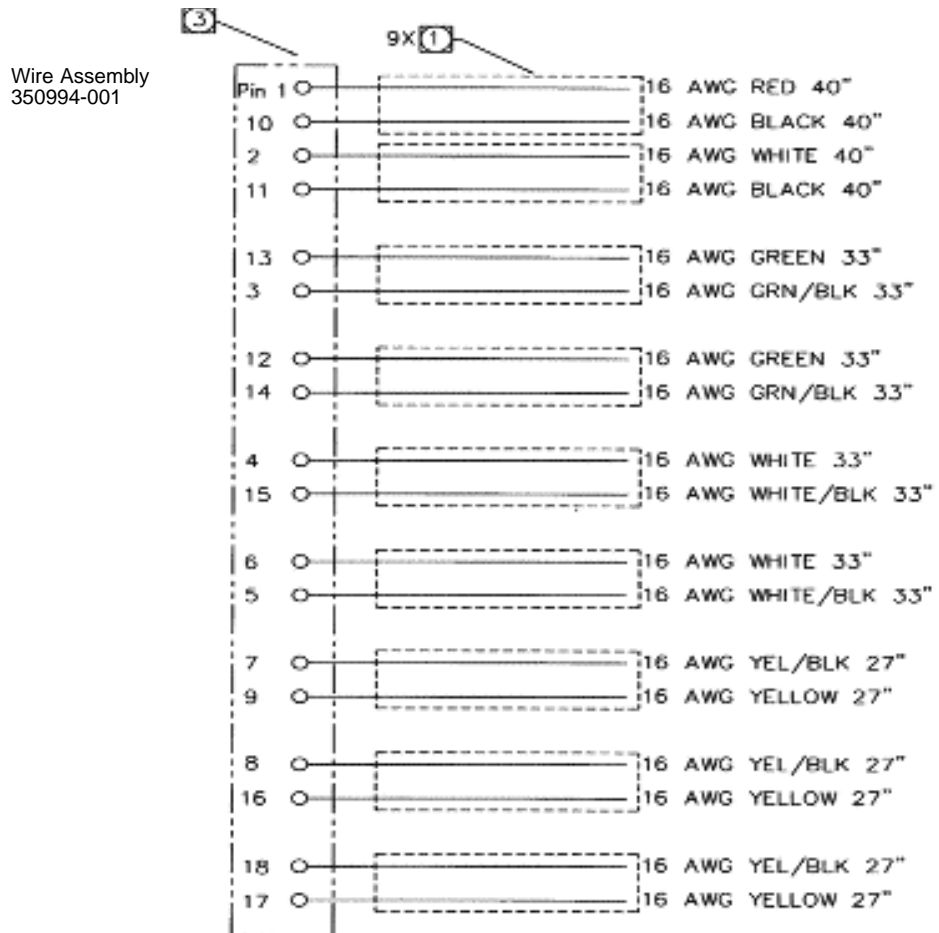

Wire Assembly
350994-001

JBL VT4889-1

COMPONENT EXPLODED VIEW

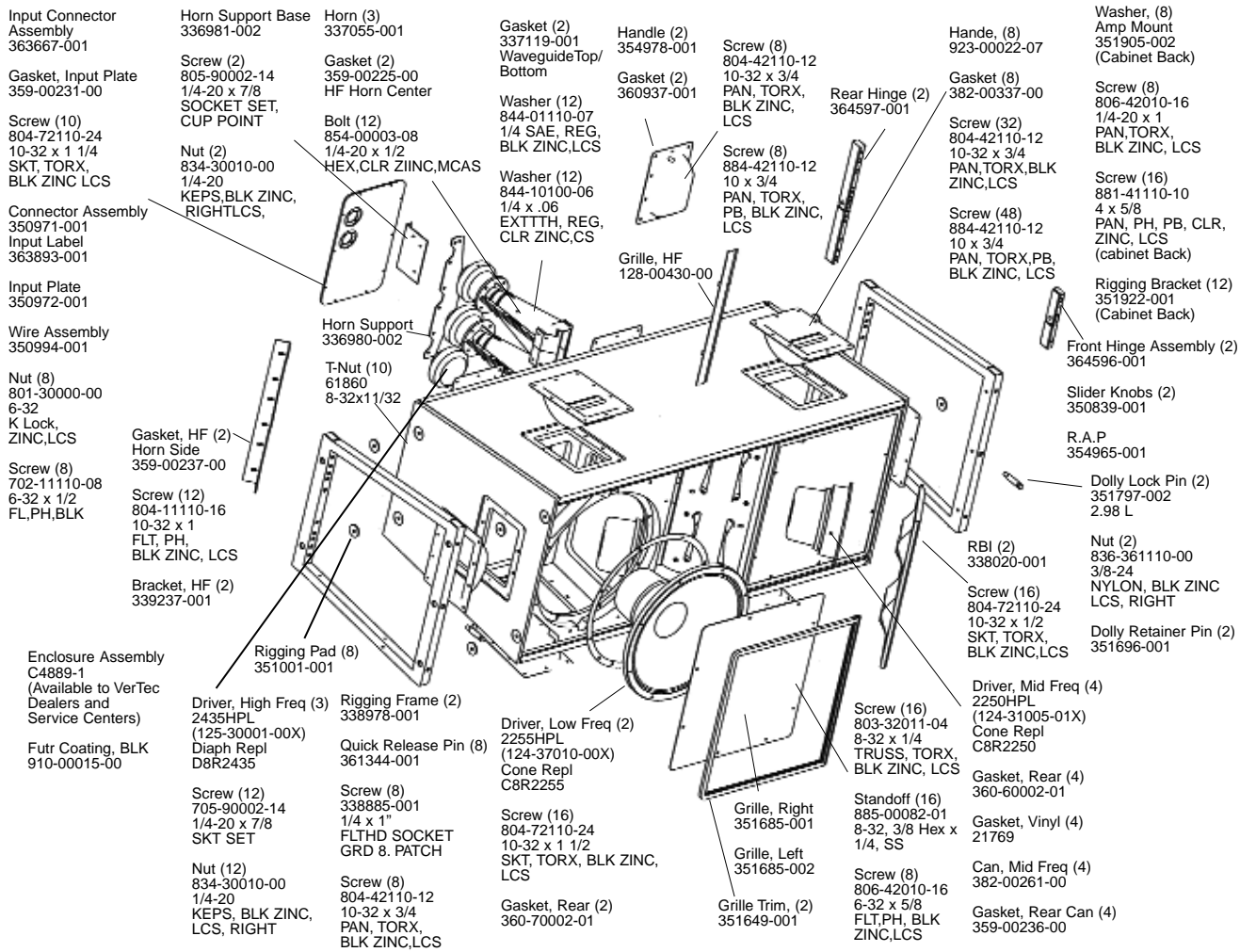

JBL VT4889-1

REV B

DOLLY ASSEMBLY 229-00029-02

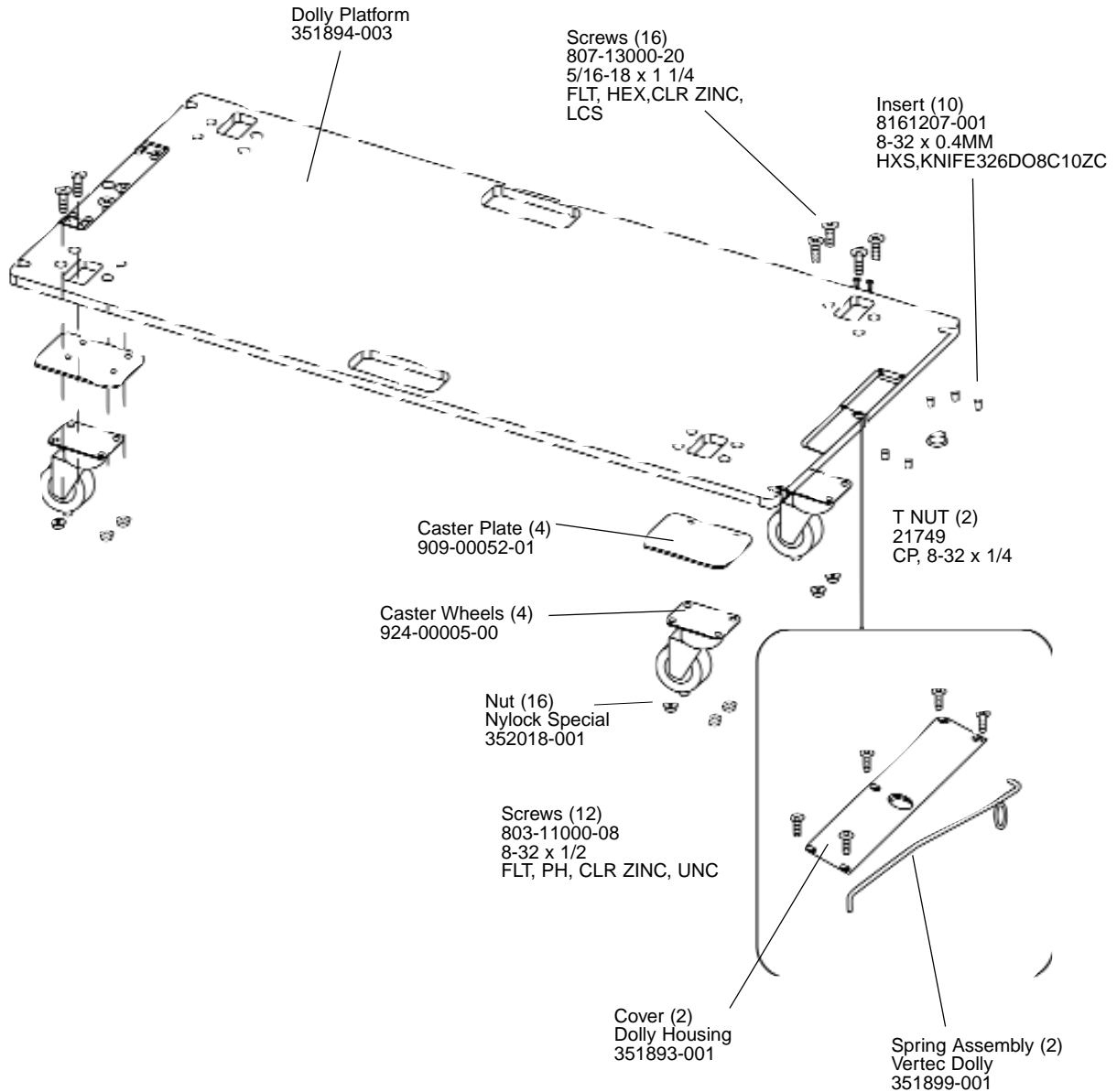

JBL VT4889-1

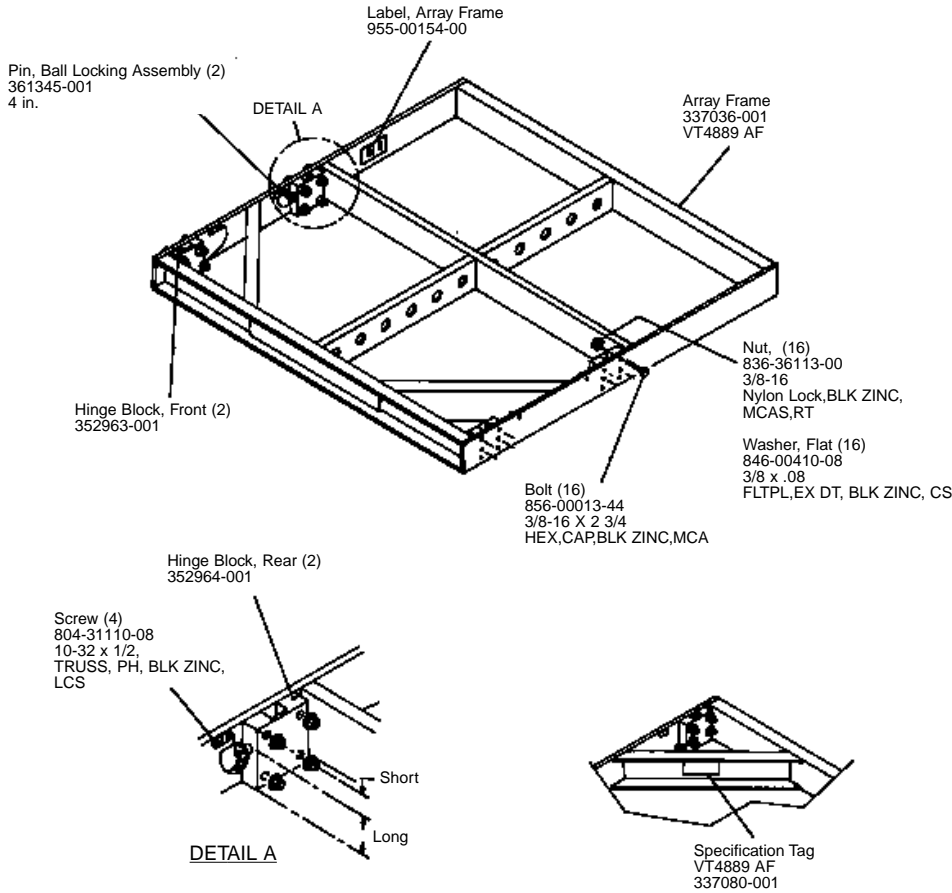

VT4889-AF (Array Frame)

The VT4889-AF array suspension frame is crafted of 6061 Grade heat-treated aluminum. It includes 11 (eleven) attachment holes for fitting 6.5-ton shackles. Each of these holes is fitted with a bronze bushing for longer life. These holes are set on approximately 102mm (4") centers. Each hole has an I.D. (Inner Diameter) of 25.4mm (1").

The frame includes four receiver blocks, designed to attach Hinge Bars from the VT4889 enclosures. These blocks are made of 7075 Grade aluminum. They are coupled with Grade 8 bolts, and the attached steel quick release pins are secured with stainless steel restraining lanyards.

The VT4889-AF weighs 45 kilograms (100 lbs.). It measures approximately 1257mm x 1129mm x 102mm (49.5" x 44.45" x 4").

VT4889 Manual
336890-001

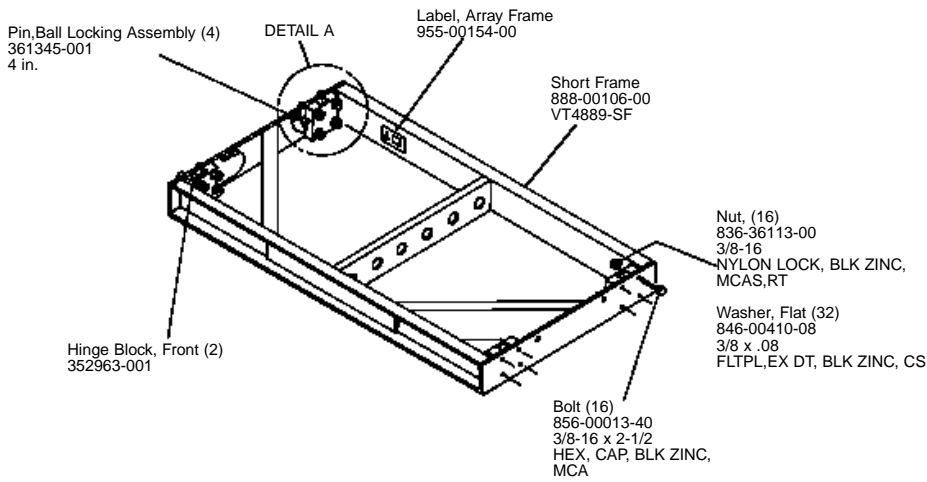

VT4889-SF (Short Frame)

Like the larger VT4889-AF, the Short Frame is crafted of 6061 Grade heat-treated aluminum. It includes 6 (six) attachment holes. Each hole is fitted with a bronze bushing for longer life. These holes are set on approximately 102mm (4") centers. Each hole has an I.D. (Inner Diameter) of 25.4mm (1"). The frame includes four receiver blocks, designed to attach Hinge Bars from the VT4889 enclosures. These blocks are made of 7075 Grade aluminum. They are coupled with Grade 8 bolts, and the attached steel quick release pins are secured with stainless steel restraining lanyards.

The VT4889-SF weighs only 23.6 kilograms (52 lbs.). It measures approximately 1257mm x 660mm x 102mm (49.5" x 26" x 4").

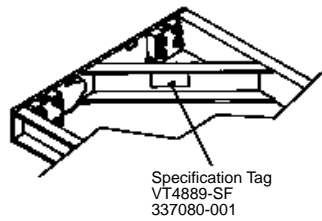
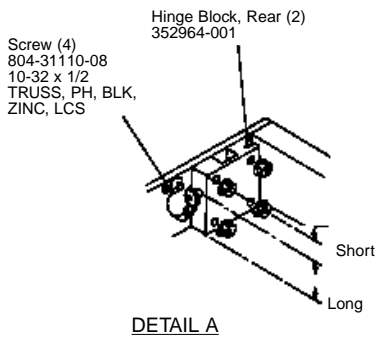

JBL VT4889-ASP/MSP/RIG

COMPONENT PARTS LIST

Acoustical Spare Parts, VT4889-ASP			
ITEM NO.	PART NO.	QTY	DESCRIPTION
1	2255HPL	1	S/M 2255HPL
2	2250HPL	2	S/M 2255HPL
3	D8R2435	1	S/M Diaphragm Repl. 2435
4	336890-001	1	SPECIFICATION SHEET VT4889
5	990-00160-00	1	CARTON
Mechanical Spare Parts, VT4889-MSP			
1	364596-001	2	FRONT HINGLE ASSY
2	364597-001	2	REAR HINGLE ASSY
3	336890-002	1	SPECIFICATION SHEET VT4889
4	338978-001	1	FRAME, RIGGING
5	337186-002	1	KIT, LF GRILLE SCREWS
6	337187-001	1	KIT, MF COVER SCREWS
7	337188-001	1	KIT, INPUT PLACE SCREWS
8	337189-001	1	KIT, DOLLY MOUNT ASSY
9	337190-001	1	KIT, PIN ASSY
10	337191-001	1	KIT, CASTER WHEEL ASSY
11	337192-001	1	KIT, SLIDER KNOBS
13	337194-001	1	FILLER, VT4889-MSP
14	337195-001	1	CARTON
15	338884-001	16	SCR, 1/4 X 3/4 FLT HD SOCKET GR8
16	338885-001	16	SCR, 1/4 X 1 FLT HD SOCKET GR8
17	950-00045-00	8	LOGO, HANDLE
18	354965-001		R.A.P.
Rigging Spare Parts, VT4889-RIG			
1	364596-001	2	FRONT HINGE ASSY
2	364597-001	2	REAR HINGLE ASSY
3	350839-001	2	SLIDER KNOBS
4	336919-001	1	CARTON VT4889-RIG
6	354965-001	1	R.A.P.

JBL VT4889-ASP/MS/RIG