

MSL-3A

Reinforcement
Loudspeaker



Designed to perform in a wide range of large-scale sound reinforcement applications, the high-power, arrayable MSL-3A allows for coherent, controlled coverage of wide areas in theater, club and concert sound reinforcement. The efficient loudspeaker delivers high sound pressure levels with extremely low distortion, for maximum intelligibility and fidelity.

The biamplified loudspeaker consists of two proprietary 12-inch low-frequency cone drivers in a unique horn-loaded,

vented enclosure, and a single high frequency driver with a 70-degree horn. The rugged, multiple-ply hardwood cabinet is fitted with handles and, optionally, aircraft-style rigging pan fittings.

The MSL-3A requires a high-quality professional stereo power amplifier capable of delivering up to 400 watts/channel continuously into 4 ohms, with a signal voltage gain of 10 dB (minimum) to 30 dB (maximum).

Features

High power

High clarity and coherence

Arrayable

Rugged

Long-term reliability

Applications

Main PA arrays

Concert reinforcement

Theater sound reinforcement

Live music club systems

High-power announcing

Paging indoors/outdoors

— 24
—
— 21
—
— 18
—
— 15
—
— 12
—
— 9
—
— 6
—
— 3
—
— 0
Inches



Meyer Sound Laboratories, Inc.
2832 San Pablo Avenue
Berkeley, CA 94702
(510) 486-1166
FAX (510) 486-8356

M E Y E R S O U N D

MSL-3A Specifications

Acoustical – MSL-3A/M-3A System

Frequency response ¹	75-18k Hz \pm 4 dB
Maximum SPL ²	
Continuous	130 dB
Peak	135 dB
HF Coverage	
Horizontal	70 degrees
Vertical	60 degrees
Acoustical Crossover Frequency	800 Hz

MSL-3A Loudspeaker

Transducers	
Low Frequency	(2) MS-12 12-inch cone drivers, 8 ohms per driver
High Frequency	MS-2001A 2-inch throat (4" diaphragm) driver, 12 ohms
High-Frequency Horn	70-degree modified radial
HF DC Protection	20 μ F Polypropylene capacitor
Enclosure	Vented, horn loaded, multi-ply Finnish birch
Finish	Black textured, charcoal-grey carpet (optional) or black weather protected (optional)
Physical Dimensions	21 $\frac{1}{4}$ " W x 56 $\frac{3}{4}$ " H x 30" D
Weight	241 lbs. (109.3 kg)
Protective Grill	Hex perforated metal screen, damped, charcoal-grey foam covering
Connector	EP-4 male, EP-5 male (Europe only), Pyle National (optional)
Rigging (optional)	Aircraft pan fittings, 600 lbs. safe working load each

M-3A Control Electronic Unit

Input Type ³	Balanced ISO-Input™, 10k ohms
Output Type	Active, push-pull, 200 ohms output impedance
Maximum Input Level	
Balanced	+23 dBu
Unbalanced	+23 dBu
Maximum Output Level ⁴	
Balanced	+26 dBu
Unbalanced	+20 dBu
Hum and Noise ⁵	-90 dBV
Dynamic Range ⁶	>110 dB
Sense Inputs	10K ohms true differential, opto-isolated
Electrical Crossover Frequency	800 Hz
High Frequency Delay Type	Active all-pass
Driver Protection Circuitry	
Low Frequency	RMS limiter
High Frequency	RMS limiter VHF Peak limiter
Indicators	
Sense; Hi and Lo	Green/ Red LEDs
Limit; Hi, Lo, and VHF	Red LEDs
Safe	Green LED
Power	Green/Red LEDs
Controls	
Front Panel	Input attenuator, AC power switch
Preset Panel	Lo Cut switch, Safe switch, HF EQ Switch VHF Var/Cal switch, VHF control

Note 1:
Measured 1 meter on-axis, half-space conditions, pink noise input, in third-octave bands.

Note 2:
Loudspeaker driven with "A" weighted noise (peak-to-RMS ratio \approx 12 dB), with power amplifier rated at 400W per channel at 4 ohms.

Note 3:
ISO™ Input: Pins 1, 2 and 3 are transformer-isolated, and shell is connected to chassis/ AC earth ground. Pin 3 positive for positive pressure output.

Note 4:
800 Hz (worst case frequency both channels), <0.1% THD.

Note 5:
"A"-weighted, unbalanced.

Note 6:
"A"-weighted noise floor to maximum output at 800 Hz.

Connectors	
Balanced Input/Output	3-pin XLR (A-3) female/male
Sense Inputs	Banana jacks
Power	120/240V AC, 50/60 Hz (internally switchable)
Physical Dimensions	19" W x 1 ³ / ₄ " H x 7 ³ / ₄ " D, Standard rack mount
Weight	8 lbs. (3.6 kg)

M-3A Control Electronics Unit

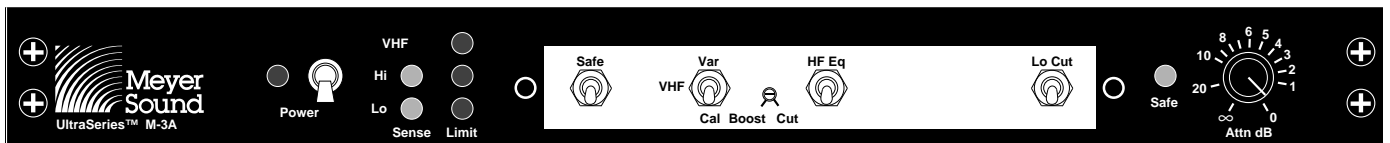

The MSL-3A loudspeaker operates as a system with the M-3A Control Electronics Unit (one per channel). Optimized for the MSL-3A and pre-aligned at the factory, the M-3A contains frequency response and phase response alignment circuitry, and Meyer Sound's exclusive SpeakerSense™ driver protection circuitry, incorporating both peak and RMS signal limiting.

A single-channel device operating at line level, the M-3A is intended to be the final component in the signal chain before the power amplifier. Its factory-calibrated SpeakerSense circuitry protects the MSL-3A loudspeaker components from damage due to overheating under high power conditions. This unique circuit continuously monitors the power applied to the MSL-3A drivers, and individually limits the high-frequency and low-frequency outputs when the safe operating limits of the drivers are exceeded.

Until the onset of overload, the SpeakerSense circuitry has no effect on the signal. Also provided is a switch-selectable Safe function which widens the safety margin of the system by decreasing the SpeakerSense limiting threshold 6 dB, and is intended to be used when extended periods of overload are anticipated.

To enhance the effectiveness of the MSL-3A in voice reinforcement applications, the M-3A incorporates filters which band-limit the system response under full-power conditions. This has the effect of increasing intelligibility by discriminating for vocal information in the signal. In music reinforcement applications, the Meyer Sound DS-2 Mid-Bass Loudspeaker and 650-R2 Concert Subwoofer are recommended to extend the system's low-frequency response and power bandwidth.

The M-3A contains logic circuits within the sense circuitry that monitors safe operating conditions. In the event of amplifier gain in excess of 32dB, amplifier failure or switched sense lines, the M-3A outputs will be muted to prevent speaker damage.

The loudspeaker system shall be of the two-way type with two 12" low-frequency loudspeakers front-mounted in a combination front-loaded horn constructed of fiberglass with two removable plugs which adjust the horn for an exponential flare, a compression driver mounted on a high-frequency fiberglass horn with a 2" throat. The low-frequency and high-frequency horns and drivers shall be securely mounted in the bass reflex hardwood-plywood enclosure, and the loudspeaker shall operate with a companion Control Electronics Unit.

The Control Electronics Unit shall contain a power supply capable of operating from a 120/240V AC, 50/60 Hz line, electronic crossover circuitry, electronic delay for the phase alignment of the high-frequency horn/driver. Low and high frequency sliding filters which automatically activate under high power conditions, RMS limiters which protect the speakers from overheating, equalization circuitry, active balanced input, indicator LED's for power on and limiters. Total harmonic

distortion shall be less than 0.1%. "A" weighted noise level shall be at least 110dB below maximum rated output of +24dBV.

The speaker system, when combined with the Control Electronics Unit and a stereo power amplifier rated at 400 watts/channel into 4 ohms, shall meet the following criteria: Frequency response, 75 to 18,000 Hz plus or minus 4 dB measured with 1/3 octave noise, 130 dB SPL of continuous pink noise output at 1 meter and peaks of 135 dB SPL. Distribution pattern, 60 degrees vertical, 70 degrees horizontal.

Speaker enclosure dimensions shall be 21 1/4" W x 56 3/4" H x 30" D, weight 241 lbs (109.3 kg).

Control Electronics Unit dimensions shall be 19" W x 1 3/4" H x 7 3/4" D, weight 8lbs (3.6 kg).

The horn loudspeaker system shall be the Meyer Sound MSL-3A. The Control Electronics Unit shall be the Meyer Sound M-3A.

Meyer Sound Laboratories has devoted itself to designing, manufacturing, and refining components that deliver superb sonic reproduction. Every part of every component is designed and built to exacting specifications and undergoes rigorous, comprehensive testing in the laboratories. Research remains an integral, driving force behind all production. Meyer strives for sound quality that is predictable and neutral over an extended lifetime and across an extended range.

Physical Dimensions

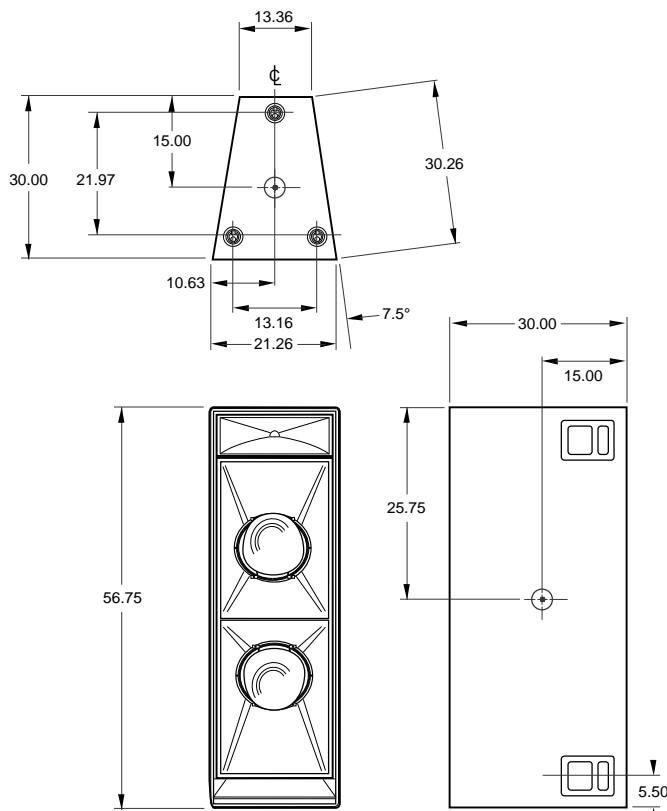

Sound engineering for the art and science of sound.



Meyer Sound Laboratories, Inc.
2832 San Pablo Avenue
Berkeley, CA 94702
(510) 486-1166
FAX (510) 486-8356