

P4T Transmitter

for use with the PSM[®] 400 Wireless Personal Monitor System

Émetteur P4T

à utiliser avec le système de retour personnel PSM 400

P4T-Sender

Zur Verwendung mit dem individuellen Monitorsystem PSM 400

Transmisor P4T

para uso con el sistema de monitor personal PSM 400

Trasmittitore P4T

da usare con il sistema di monitoraggio individuale PSM 400



ENGLISH	3
FRANÇAIS	8
DEUTSCH	13
ESPAÑOL	18
ITALIANO	23



WARNING!

**USING THIS SYSTEM AT EXCESSIVE VOLUMES CAN CAUSE PERMANENT HEARING DAMAGE.
USE AS LOW A VOLUME AS POSSIBLE.**

In order to use this system safely, avoid prolonged listening at excessive sound pressure levels. Please use the following guidelines established by the Occupational Safety Health Administration (OSHA) on maximum time exposure to sound pressure levels before hearing damage occurs.

- 90 dB SPL at 8 hours
- 95 dB SPL at 4 hours
- 100 dB SPL at 2 hours
- 105 dB SPL at 1 hour
- 110 dB SPL at 1/2 hour
- 115 dB SPL at 15 minutes

120 dB SPL - avoid or damage may occur

It is difficult to measure the exact Sound Pressure Levels (SPL) present at the eardrum in live applications. In addition to the volume setting on the PSM, the SPL in the ear is affected by ambient sound from floor wedges or other devices. The isolation provided by the fit of quality earphones is also an important factor in determining the SPL in the ear.

Here are some general tips to follow in the use of this product to protect your ears from damage:

1. Turn up the volume control only far enough to hear properly.
2. Ringing in the ears may indicate that the gain levels are too high. Try lowering the gain levels.
3. Have your ears checked by an audiologist on a regular basis. If you experience wax buildup in your ears, stop using the system until an audiologist has examined your ears.
4. Wipe the earphones with an antiseptic before and after use to avoid infections. Stop using the earphones if they are causing great discomfort or infection.



This symbol indicates that there are important operating and maintenance instructions in the literature accompanying this unit.

LICENSING INFORMATION

Changes or modifications not expressly approved by Shure Incorporated could void your authority to operate the equipment. Licensing of Shure wireless microphone equipment is the user's responsibility, and licensability depends on the user's classification and application, and on the selected frequency. Shure strongly urges the user to contact the appropriate telecommunications authority concerning proper licensing, and before choosing and ordering frequencies.

THIS RADIO EQUIPMENT IS INTENDED FOR USE IN MUSICAL PROFESSIONAL ENTERTAINMENT AND SIMILAR APPLICATIONS.

NOTE: THIS EQUIPMENT MAY BE CAPABLE OF OPERATING ON SOME FREQUENCIES NOT AUTHORIZED IN YOUR REGION. PLEASE CONTACT YOUR NATIONAL AUTHORITY TO OBTAIN INFORMATION ON AUTHORIZED FREQUENCIES FOR WIRELESS MICROPHONE PRODUCTS IN YOUR REGION

Licensing: Note that a ministerial license to operate this equipment may be required in certain areas. Consult your national authority for possible requirements.

Shure Transmitter Model P4T may be used in the countries and frequency ranges listed in Table 1 on page 28.

INTRODUCTION

Thank you for buying the P4T Transmitter. The P4T is a component in the PSM[®] 400 family of wireless personal monitors. When used with a P4R Receiver, it provides the many advantages of an in-ear monitoring system, including:

- **Improved Sound Quality** - high fidelity without the risk of feedback,
- **Increased Mobility** - your mix moves with you,
- **Personal Control** - through volume adjustment and MixMode[®].

For further information on the PSM 400 system, see the PSM 400 Wireless Personal Performance Pack User's Guide, available on the web at www.shure.com.

P4T TRANSMITTER FEATURES

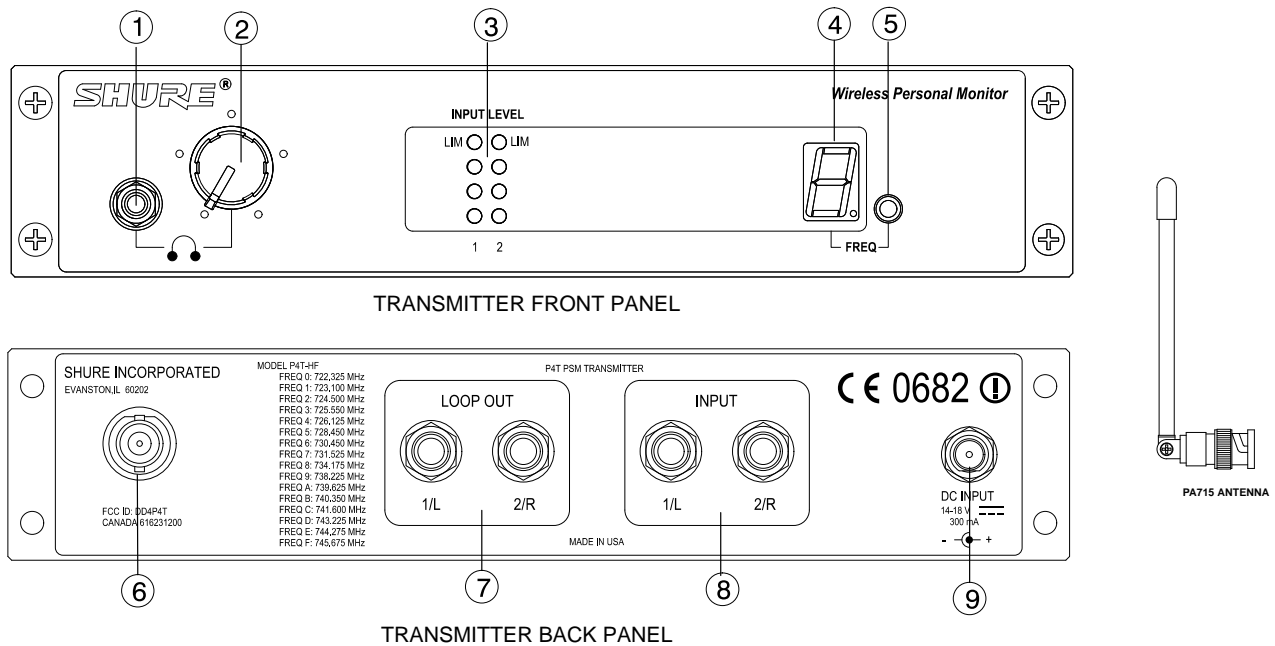

1. **Local Earphone Output Jack (1/8 inch):** Connects to earphones.
2. **Local Earphone Level Control:** This knob adjusts the volume of the local earphone jack's amplifier. Always listen at low levels.
3. **Input Level LEDs:** Two vertical strings of four LEDs display the input level of the left and right input channels. The four LEDs on the left display the status of the signal from channel 1 and the four LEDs on the right display the status of the signal from channel 2:

LED	Signal Status
RED (top)	Limiters Active
YELLOW (middle)	Nominal Level
GREEN (bottom two)	Signal Present
4. **Transmission Frequency LED:** This indicates which of the 16 channels (0-9 or A-F) is transmitting.
5. **Frequency Select Button:** This recessed button changes the transmission channel. (Use a 1/4" plug to press this button.)
6. **Antenna Connector 50 Ω, BNC type:** This connects to the antenna to transmit UHF signals to the receiver.
7. **LOOP OUT Jacks:** Two 1/4" TRS jacks allow the audio signal to pass through the transmitter to other devices, including other transmitters, tape recorders, or amplifiers.
8. **INPUT Jacks:** Two 1/4" TRS switching jacks are line level audio inputs.
9. **DC INPUT Connector:** Input for PS40 power cord.

SET UP AND OPERATION

Follow these directions to set up the transmitter for operation.

1. Plug the power cord into the transmitter's DC INPUT power connector. Plug the other end of the power cord into a wall outlet.
2. Attach the antenna to the ANTENNA OUT BNC connector.
3. Connect line level outputs of an audio source into the audio INPUTS of the transmitter. Use both of the input jacks for a two-channel source. Use either input jack for a mono source. The P4T transmits in MixMode/stereo if both inputs are used, but automatically transmits in mono if only one input is used.

NOTE: All inputs are phantom power protected up to 50 VDC.

4. Select an operating frequency using the Frequency Select Button. Push the button repeatedly until the LED displays the desired chan-

nel. The display flashes. Push and hold the button until the flashing stops to confirm the change (use a 1/4" plug to press the button).

IMPORTANT: Never set more than ONE transmitter to the same operating frequency.

5. Once the P4T transmits audio, observe the input level LEDs. If the LEDs consistently illuminate red, decrease the output level of the audio source until the red LEDs flicker occasionally.
6. Set up the P4R receiver as directed in the P4R user's guide. Make sure that the frequency selected on the receiver matches the frequency selected on the transmitter.

LOOP APPLICATIONS

The LOOP OUT 1/L and 2/R outputs route the transmitter's incoming signal to other devices. Use the loop feature of the transmitter in any number of applications, such as the following:

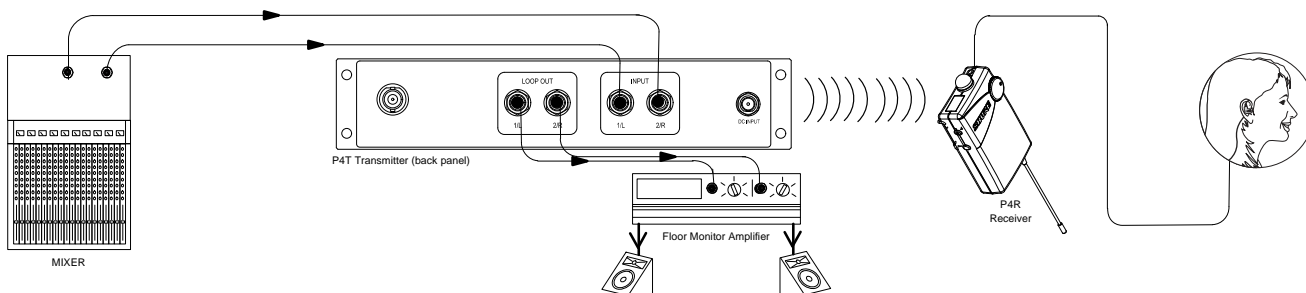

Operating Floor Monitors Through a P4T Transmitter: Send an audio signal through the LOOP connectors to a floor monitor amplifier. In this set up, the receiver and the onstage monitors reproduce the same audio.

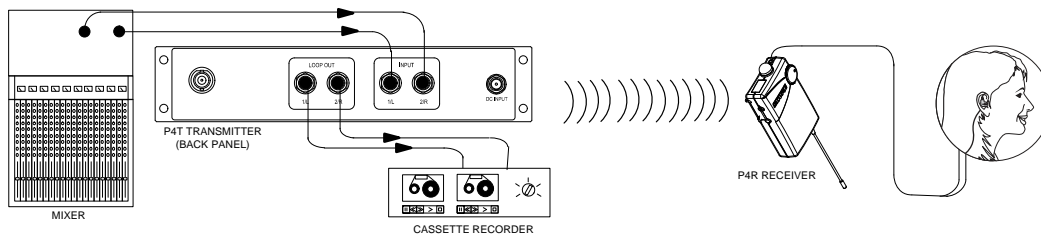

Making a Recording Through a P4T Transmitter: To record a performance, connect the LOOP outputs to the inputs of a tape deck, DAT, or other recording device.

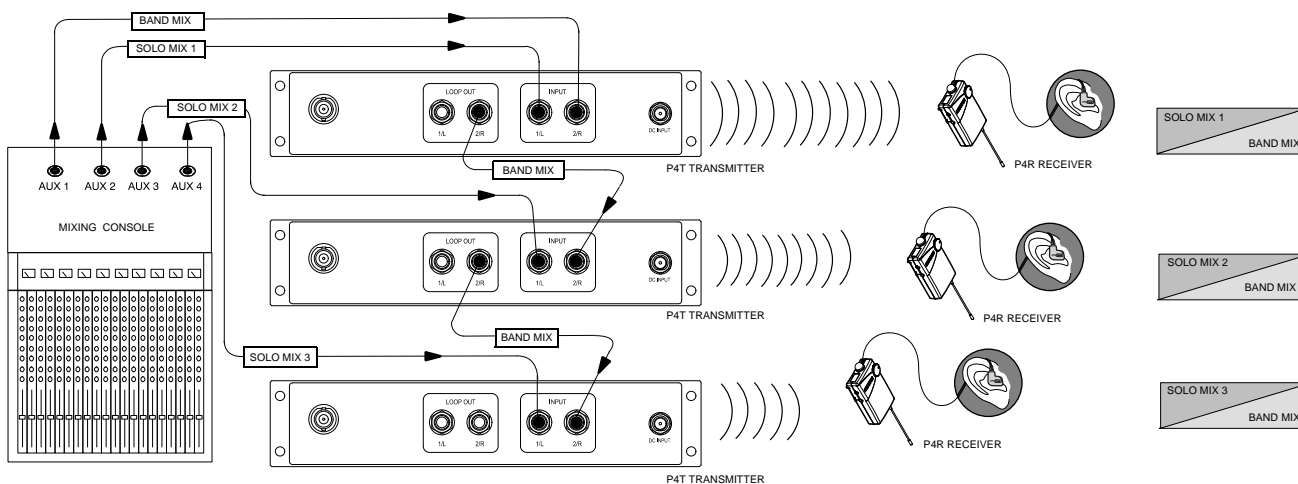

Operating Multiple PSM Wireless Systems Under MixMode Control: Send a band mix from a mixer to a P4T transmitter, then send the band mix on to other transmitters using the P4T's LOOP OUT feature. Also send independent monitor mixes or direct outputs to the second channel of each transmitter. The entire band receives the same band mix, while each individual player also hears a solo mix of their own. Use the MixMode control on the P4R receiver to adjust the level between the solo mix and the band mix.

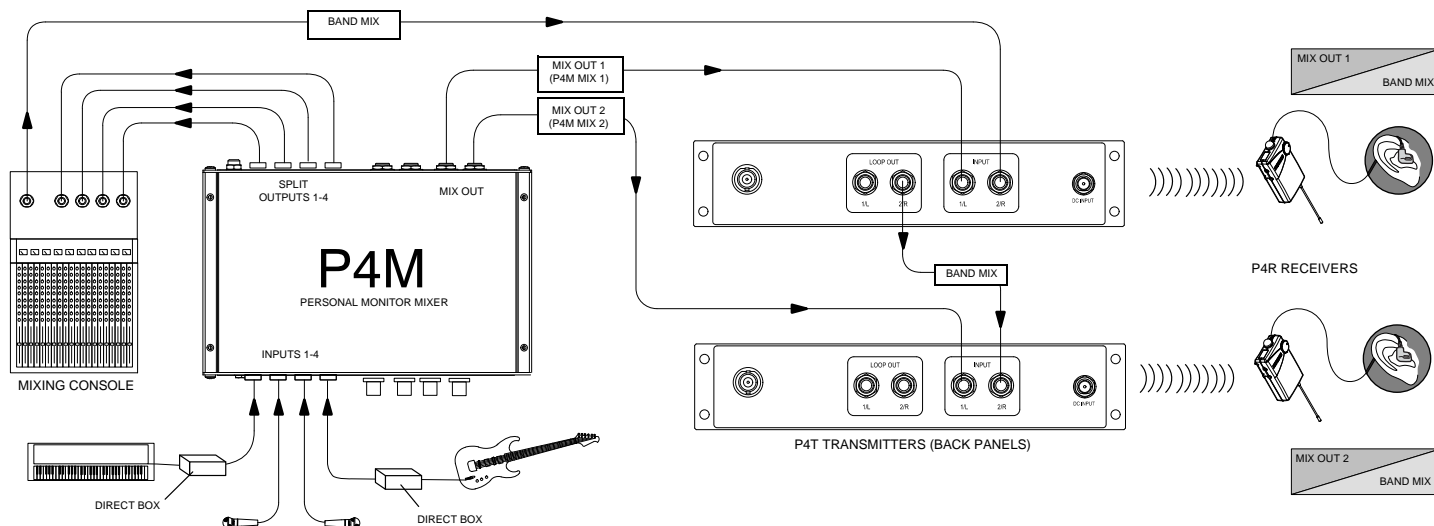

Operating Two PSM Wireless Systems Under MixMode Control From a P4M Mixer: Send a band mix from a mixing console to a P4T transmitter, then send the band mix to a second transmitter using the P4T's LOOP OUT feature. Create an individual mix for each transmitter using the P4M mixer. Send the mix to each transmitter using the P4M's MIX OUT 1 or MIX OUT 2 outputs. Use the MixMode control on the P4R receiver to adjust the levels between the band mix and the P4M mix (for more information on the P4M Personal Monitor Mixer, see the P4M User's Guide or the PSM 400 Wireless Personal Performance Pack User's Guide, available at www.shure.com).

SPECIFICATIONS

RF Frequency Range

722 to 952 MHz (country dependent)

Operating Range

300 feet (environment dependent)

RF Output Power

50 mW (+17 dBm) typical conducted (country dependent)

Modulation Limiter

Internal peak limiter (>10:1 compression)

Antenna

External whip, 50 Ω BNC connector

Power Requirements

Operating voltage 14-18 Vdc

Supplied with one of the following external power supplies:

- Model PS40: 120 Vac, 60 Hz input.
- Model PS40E, Model PS40UK: 230 Vac, 50/60 Hz input.
- Model PS40AR: 220 Vac, 50 Hz input.

Current

250 mA maximum

Dimensions

219.2 mm X 43.6 mm X 136.5 mm (8.63 in. X 1.718 in. X 5.375 in.)

Net Weight

907.2 g (2 lbs., 0 oz.)

CERTIFICATION

P4T: Certified to FCC Part 74, FCC ID DD4P4T. Certified in Canada by IC under RSS-123.

EP4T: Meets essential requirements of European R&TTE Directive 99/5/EC, eligible to bear CE mark: **CE O682 D**. Type approved to EN 300 422 Parts 1 and 2. Meets requirements of EMC Standard EN 301 489 Parts 1 and 9.

PS40: Conforms to applicable U.S. and Canadian electrical and safety standards.

PS40AR: Conforms to Safety Standard IEC 60065. Certified TÜV Rheinland Argentina, S.A. No. RA2681022.

PS40E/PS40UK: Conforms to European low voltage directive 72/23/EEC. Eligible to bear CE marking.

Furnished Accessories

1/4 Wave Transmitter Antenna.....	PA715: 518-752 MHz
.....	UA400 (95B8699): 774-952 MHz
Bulkhead Adapter.....	95A8994
22 inch BNC Cable.....	95A2035
Single Mount Rack Bracket.....	53C8484
Dual Mount Rack Bracket.....	53B8484
Straddle Bars.....	53A8443

AC Adaptor

PS40 (120V), PS40E (230V), PS40UK (230V), PS40AR (220V)

Optional Accessories

Antenna Combiner.....	PA770 (120 VAC)
.....	PA770E (240 VAC)
Unidirectional Antenna.....	PA705
10 ft Coaxial Antenna Cable (BNC connector)	PA725

CONNECTORS

P4T Audio Inputs (1/L and 2/R)

Connector Type:	1/4-inch jack (female) TRS
Configuration:	electronically balanced
Actual Impedance:	20 kΩ
Nominal Input Level:	-10 dBV/-7.8 dBu
Maximum Input Level:	+15 dBu
Pin Assignments:	Tip = hot ring = cold sleeve = ground
Phantom Power Protection?	Yes. Up to 50 VDC

P4T LOOP Outputs (1/L and 2/R)

Connector Type:	1/4-inch jack (female) TRS
Configuration:	electronically balanced
Actual Impedance:	20 kΩ
Nominal Output Level:	-10 dBV/-7.8 dBu
Maximum Output Level:	+15 dBu
Pin Assignments:	Tip = hot ring = cold sleeve = ground
Phantom Power Protection?	Yes Up to 50 VDC

RACK MOUNTING THE P4T

The P4T features a $\frac{1}{2}$ -rack chassis specially designed for sturdiness. This eliminates the sagging and bending found in most $\frac{1}{2}$ -rack designs. The brackets and straddle bars ensure that the units will be installed securely.

WARNING: Do not torque the screws too tightly, or the chassis may be damaged.

SINGLE UNIT

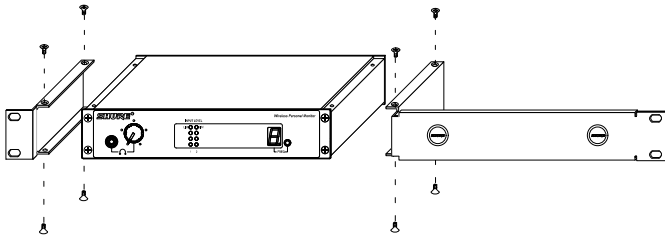

DUAL-MOUNTED UNITS

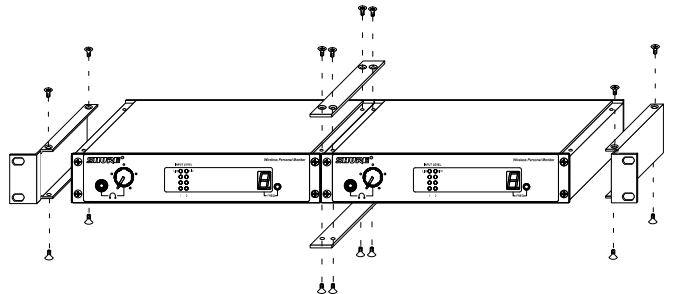

MOUNTING IN AN EQUIPMENT RACK

NOTE: Be sure to use both straddle bars when installing dual units.

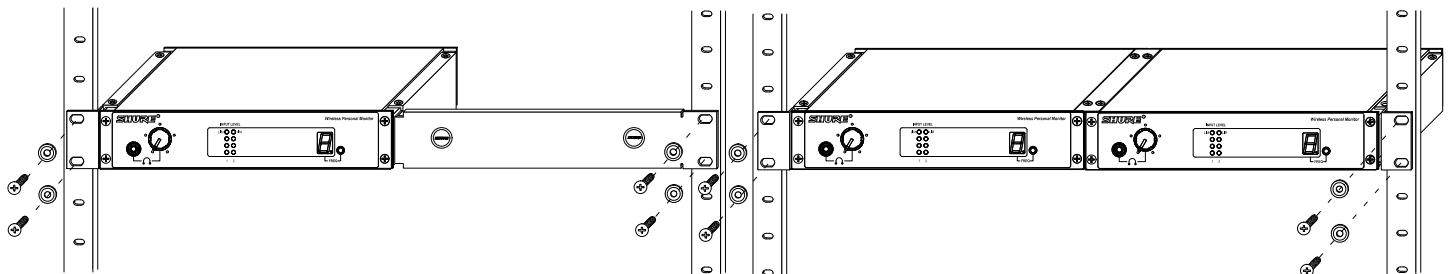

FRONT MOUNTING THE ANTENNA

The P4T transmitter comes equipped so the antenna can be front-mounted. Front-mounting prevents antenna cables from becoming entangled and greatly minimizes RF interference from other cables. When a unit is located in a rack, antennas should be either front- or remote-mounted.

1. Insert the bulkhead adapter through either hole of the mounting bracket and secure it from the back using the supplied hardware.

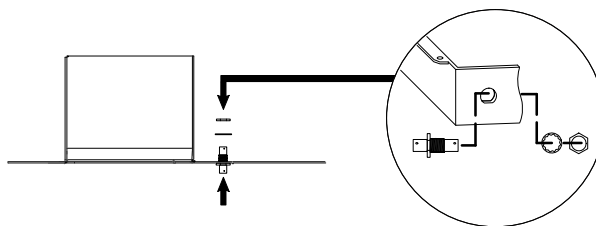

2. Connect the transmitter antenna output to the bulkhead adapter with the supplied RF cable.

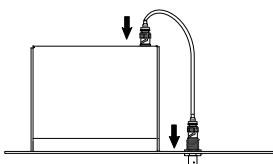

3. Install the antenna on the bulkhead adapter.

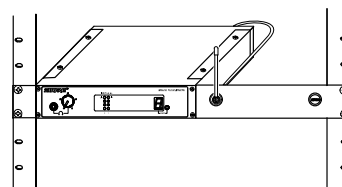

NOTE: The PA715 antenna, which comes supplied with the P4T, cannot be remote mounted. Use a PA705 antenna for remote mounting.

TABLE 1 TABLEAU 1 TABELLE 1 TABLA 1 TABELLA 1

Country Code Code de Pays Länder-Kurzel Código de país Codice del Paese	P4T-HF (722 - 746 MHz)	P4T-P3 (722 - 746 MHz)	P4T-MN (800 - 830 MHz)	P4T-KE (842 - 952 MHz)
A	722 - 746 MHz *	*	800 - 830 MHz *	842 - 952 MHz *
B	722 - 746 MHz *	*	800 - 830 MHz *	842 - 952 MHz *
CH	722 - 746 MHz *	*	800 - 830 MHz *	842 - 952 MHz *
D	722 - 746 MHz *	*	800 - 830 MHz *	842 - 952 MHz *
E	722 - 746 MHz *	*	800 - 830 MHz *	842 - 952 MHz *
F	*	722 - 746 MHz *	*	*
GB	722 - 746 MHz *	*	*	842 - 952 MHz *
GR	722 - 746 MHz *	*	800 - 830 MHz *	842 - 952 MHz *
I	722 - 746 MHz *	*	*	863 - 952 MHz*
IRL	722 - 746 MHz *	*	800 - 830 MHz *	842 - 952 MHz *
L	722 - 746 MHz *	*	800 - 830 MHz *	842 - 952 MHz *
NL	722 - 746 MHz *	*	800 - 830 MHz *	842 - 952 MHz *
P	722 - 746 MHz *	*	800 - 830 MHz *	842 - 952 MHz *
DK	*	*	800 - 820 MHz *	863 - 952 MHz*
FIN	*	*	800,1 - 819,9 MHz *	863 - 952 MHz*
N	*	*	800 - 820 MHz *	863 - 952 MHz*
S	*	*	800 - 814 MHz *	863 - 952 MHz*
All Other Countries Tous les autres pays Alle anderen Länder Demás países Tutti gli altri Paesi	*	*	*	*

*Please contact your national authority for information on available legal frequencies for your area and legal use of the equipment.

*Se mettre en rapport avec les autorités compétentes pour obtenir les informations sur les fréquences autorisées disponibles localement et sur l'utilisation autorisée du matériel.

*Für Informationen bezüglich der für Ihr Gebiet verfügbaren gesetzlich zugelassenen Frequenzen und der gesetzlichen Bestimmungen für den Einsatz der Geräte setzen Sie sich bitte mit der zuständigen örtlichen Behörde in Verbindung.

* Comuníquese con la autoridad nacional para obtener información en cuanto a las frecuencias legales disponibles y usos legales del equipo en su área.

*Rivolgersi alle autorità competenti per ottenere informazioni relative alle frequenze autorizzate nella propria regione e alle norme che regolano l'uso di questo apparecchio.



United States:
Shure Incorporated
5800 West Touhy Avenue
Niles, IL 60714-4608 USA

Phone: 847-600-2000
Fax: 847-600-1212
Email: info@shure.com

Europe, Middle East, Africa:
Shure Europe GmbH
Wannenäckestr. 28,
74078 Heilbronn, Germany

Phone: 49-7131-72140
Fax: 49-7131-721414
Email: info@shure.de

Asia, Pacific:
Shure Asia Limited
Unit 301, 3rd Floor
Citicorp Centre
18, Whitfield Road
Causeway Bay, Hong Kong

Phone: 852-2893-4290
Fax: 852-2893-4055
Email: info@shure.com.hk

**Canada, Latin America,
Caribbean:**
Shure Incorporated
5800 West Touhy Avenue
Niles, IL 60714-4608 USA

Phone: 847-600-2000
Fax: 847-600-6446
Email: international@shure.com