

STAGEPAS Series

Portable PA Systems



STAGEPAS 500



STAGEPAS 300



* The speaker stand and microphone stand are options.

Great live sound has never been easier.

- This all-in-one system includes a pair of passive speakers, a detachable powered mixer, and a pair of speaker cables.
- Both the 8-channel 150W + 150W STAGEPAS 300 mixer and the 10-channel 250W + 250W STAGEPAS 500 mixer can be used either while installed in the speaker compartment or detached for easy positioning and access.
- Built-in equalization and reverb add the finishing touches to your sound.
- STAGEPAS 500 features phantom power for condenser microphones and channel compression/limiting for added sonic control.
- XLR and phone-jack inputs on mono channels, and phone-jack and RCA pin-jack inputs on stereo channels allow connection to a wide range of sources.
- MIC/LINE switches select microphone or line level input matching for channels 1 through 4.
- The STAGEPAS 300 speakers can be stand mounted using standard speaker stand adaptors such as the ADP138, Ultimate BMB200, or equivalent. STAGEPAS 500 speaker is directly mountable on 35mm pole with securing thumb screw.
- Auto Limiter prevents overload damage to power amplifier and speakers.
- LED output level meter.
- Optional BMS-10A Mic Stand Adaptor for the mixer unit.

OPTIONS (MSP5 STUDIO)

BMS10A Mic Stand Adaptor



The optional BMS-10A Mic Stand Adaptor makes it easy to mount the mixer on a microphone stand.

STAGEPAS 500

GENERAL SPECIFICATIONS (MIXER)

Output Power (Maximum)	250W+250W(±10%)/4Ω @10% THD at 1kHz (SPEAKERS L/R)
Output Power (RMS)	200W+200W/4Ω @1% THD at 1kHz (SPEAKERS L/R)
Maximum Output Level	116dB (1m)
Frequency Response (Nominal output level@1kHz)	-3dB, 0dB, +1dB @20Hz-20kHz (MUSIC/SPEECH=MUSIC) (MONITOR OUT) -3dB, 0dB, +1dB @80Hz-20kHz (MUSIC/SPEECH=SPEECH) (REC OUT) -3dB, 0dB, +1dB @20Hz-20kHz, 1W OUTPUT (MUSIC/SPEECH=MUSIC, without Speaker EQ) (SPEAKERS L/R)
Total Harmonic Distortion	Less than 0.5% @20Hz, 1kHz, 20kHz +14dBu GAIN=nominal (MONITOR OUT, REC OUT)
Hum & Noise (Equivalent Input Noise, Rs=150Ω, MIC/LINE = MIC)	Less than -106dBu (CH1/2) Less than -112dBu (CH3/4) Less than -65dBu residual output noise (SPEAKERS L/R)
Crosstalk (@1kHz)	Less than -70dB between input channels
Phantom power switch	ON / OFF (CH1-4)
COMP/LIMIT switch	ON=COMP, OFF=LIMIT (CH1/2)
Input Channel Equalization	±15 dB HIGH: 10kHz shelving LOW: 100Hz shelving
Power Consumption	65W
Dimensions (W x H x D)	342 x 544.5 x 298mm (13.5" x 21.4" x 11.7") [Speaker x 1] 330 x 175 x 111.5mm (13.0" x 6.9" x 4.4") [Mixer]
Weight	24.0kg (52.9lbs) [Speaker x 2 + Powered Mixer]

SPEAKER (SPEAKERS)

Enclosure	2-way bass-reflex type, Polypropylene, Black
Crossover Frequency	4.0kHz (LF:12dB/oct, HF:12dB/oct)
Frequency Range	55Hz-20kHz (-10dB)
Speaker Unit	LF: 10" (25cm) Cone HF: 1" (2.54cm) Compression Driver

DIMENSIONS

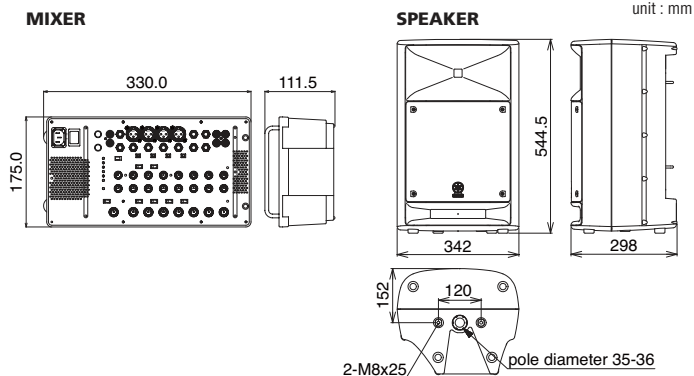

STAGEPAS 300

GENERAL SPECIFICATIONS (MIXER)

Output Power (Maximum)	150W + 150W / 6Ω @10% THD at 1kHz (SPEAKERS L/R)
Output Power (RMS)	100W + 100W / 6Ω @ 1% THD at 1kHz (SPEAKERS L/R)
Frequency response	-3dB, 0dB, +1dB @20Hz-20kHz, 1W Output/6Ω (MUSIC/SPEECH switch=[SPEECH])(SPEAKERS L/R) -3dB, 0dB, +1dB @20Hz-20kHz, +4dBu 10kΩ load (MUSIC/SPEECH switch=[MUSIC])(MONITOR OUT,REC OUT)
Total harmonic distortion	Less than 1% @1kHz, 50W Output Power (SPEAKERS L/R) Less than 0.5% @20Hz-20kHz, +14dBu 10kΩ load (MONITOR OUT,REC OUT)
Hum & noise^{*1}	Less than -65dBu (Residual noise)(SPEAKER OUT) Less than -90dBu (Residual noise)(MONITOR OUT,REC OUT)
Crosstalk (@1kHz)	Less than -70dB
Channel EQ	HIGH: 10kHz shelving LOW: 100Hz shelving
Dimensions (W x H x D)	275 x 456 x 255mm (10.8" x 18.0" x 10.0") [Speaker x 1] 290 x 96 x 160mm (11.4" x 3.8" x 6.3") [Mixer]
Weight	18.0kg (39.7lbs) [Speaker x 2 + Powered Mixer]
Power consumption	70W

GENERAL SPECIFICATIONS (SPEAKERS)

Enclosure	Bass-reflex type
Speaker unit	LF:8" (20cm) cone HF:1" (2.54cm) Compression driver
Crossover frequency	4kHz
Frequency range	55Hz to 20kHz
Maximum output level	112dB (1m)

*1 20Hz-20kHz, Rs=150ohms, MIC/LINE switch=MIC

*2 Shelving turnover/rolloff frequency: 3dB before maximum or boost.

DIMENSIONS

