



ShowMatch™ DeltaQ™ Array Loudspeakers

Installation and Safety Guidelines
Instrucciones de Instalacion y de Seguridad
Installation et Instructions de Sécurité
Installations- und Sicherheitshinweise



Please read this installation guide carefully and save it for future reference.

This product is intended for installation by professional installers only! This document is intended to provide professional installers with basic installation and safety guidelines for this product in typical fixed-installation or portable-system applications. Please read this document and all safety warnings before attempting installation.

WARNINGS:



- All Bose® products must be installed in accordance with local, state, federal and industry regulations. It is the installer's responsibility to ensure installation of the loudspeakers and mounting system is performed in accordance with all applicable codes, including local building codes and regulations. Consult the local authority having jurisdiction before installing this product.
- Unsafe mounting or overhead suspension of any heavy load can result in serious injury or death, and property damage. It is the responsibility of the installer to evaluate the reliability of any mounting method used for their application. Only professional installers with the knowledge of proper hardware and safe mounting techniques should attempt to install any loudspeaker overhead.

CAUTION:



- Installed loudspeaker arrays require regular inspection and routine maintenance to ensure proper function and safe operation. Inspect mounting hardware and attachments for signs of corrosion, bending or any other condition that may decrease the structural integrity. Immediately replace worn or damaged components.
- Do not make unauthorized alterations to this product; doing so may compromise safety, regulatory compliance, system performance, and may void the warranty.
- Never exceed 24 ShowMatch full-range or 18 ShowMatch subwoofer modules using the integrated rigging system for arrays. Please refer to product labels for Working Load Limit data.

NOTE: Always use Bose Modeler® or Bose Array Tool software to confirm safe working load limits with exact array configurations, pitch angles, and connection points.

Guidelines for Installation and Setup of ShowMatch™ DeltaQ™ Array Module Loudspeakers

The installation information contained in this document is only a general guideline and cannot, as such, represent all requirements and precautions. Accordingly, anyone using this material assumes all liability and is expressly responsible for the safety of all loudspeaker array designs and mounting configurations applied in practice.

- Prior to the installation or portable-system setup of any overhead loudspeaker, a licensed professional engineer must approve the location and method of attachment to the building structure or support-truss structure and confirm they are consistent with all building codes and regulations. Ensure the mounting surface and the method of attaching the loudspeaker system to the surface is capable of supporting the total weight of the system. A safety factor of 10:1 is recommended.
- Obtain all mounting system components from reputable manufacturers. Select a mounting system appropriate for your loudspeaker system and its intended application. We recommend Bose mounting accessories when available. A licensed professional engineer must review the design and fabrication of any custom mounting hardware.
- Bose ShowMatch array module loudspeakers feature an integrated quick-pin rigging system, designed to facilitate loudspeaker array mounting by professional installers. Module to module connections should be made using only the integrated rigging link-bars with the included or optional load-rated "quick pin" fasteners. Unmarked (not rated for load bearing) fasteners should not be used.
- Do not suspend loudspeaker using handles as attachment points. Handles are NOT designed for load bearing!
- Use a safety cable, separately attached to the cabinet, at a point not in common with the load bearing attachment points of the mounting system to the loudspeaker. This is recommended even if not required by local regulation. Consult a licensed professional engineer or a rigging professional for proper design and installation.
- Do not under any circumstances climb the array.

Lea detenidamente esta guía de instalación y consérvela para consultarla en el futuro.

Este producto está diseñado para que solo instaladores profesionales realicen su instalación. Este documento está diseñado para proveer las pautas de seguridad e instalación básicas a los instaladores profesionales de este producto en aplicaciones de sistema portátil e instalación fija comunes. Lea este documento y todas las advertencias de seguridad antes de comenzar la instalación.

ADVERTENCIAS:

- Todos los productos Bose® deben instalarse según las reglamentaciones locales, estatales, federales y del sector. Es responsabilidad del instalador garantizar que la instalación del sistema de soporte y los altavoces se realice conforme a los códigos aplicables, incluidos los códigos y las reglamentaciones de construcción locales. Consulte a la autoridad local competente antes de instalar este producto.
- El montaje inseguro o la suspensión en alturas de cualquier carga pesada puede provocar lesiones graves o la muerte, además de daños a la propiedad. Es responsabilidad del instalador evaluar la fiabilidad de cualquier método de montaje utilizado para su aplicación. Solo los instaladores profesionales con el conocimiento de los componentes físicos adecuados y las técnicas de montaje seguro deberían intentar instalar cualquier altavoz en altura.

PRECAUCIÓN:

- Se deben inspeccionar regularmente los arreglos instalados de altavoz, además de realizarles mantenimiento de rutina con el propósito de garantizar su funcionamiento adecuado y operación segura. Revise los accesorios y los componentes físicos para instalación, y busque signos de corrosión, torcimiento o cualquier otra condición que pueda disminuir la integridad estructural. Sustituya inmediatamente los componentes desgastados o dañados.
- Solo realice alteraciones autorizadas a este producto. De lo contrario, podría comprometer la seguridad, el cumplimiento de las reglamentaciones y el rendimiento del sistema; además, podría anular la garantía.
- Nunca exceda 24 módulos de rango completo ShowMatch o 18 módulos de subwoofer ShowMatch usando el sistema de montaje integrado para los arreglos. Consulte las etiquetas de producto para obtener información sobre los datos del límite de carga de trabajo.

Nota: Utilice siempre el software Modeler® o "Bose Array Tool" para confirmar los límites de seguridad de carga de trabajo con cada configuración del arreglo, ángulos de inclinación y los puntos de conexión.

Pautas de instalación y configuración de los altavoces de arreglo modular ShowMatch™ DeltaQ™

La información de instalación incluida en este documento solo corresponde a pautas generales y, como tal, no puede representar todos los requisitos ni todas las precauciones. Por lo tanto, todo aquel que utilice este material asume toda la responsabilidad y es expresamente responsable de todos los diseños de arreglo y las configuraciones de montaje del altavoz realizadas en la práctica.

- Antes de la instalación o la configuración del sistema portátil de cualquier altavoz en altura, un ingeniero profesional licenciado debe aprobar la ubicación y el método de fijación a la estructura del inmueble o a la estructura colgante, y confirmar que sean compatibles con todos los códigos y las reglamentaciones de construcción. Asegúrese de que la superficie de montaje y el método de fijación a la superficie del sistema de altavoces pueda soportar el peso total del sistema. Se recomienda un factor de seguridad de 10:1.
- Obtenga todos los componentes de montaje del sistema de fabricantes acreditados. Seleccione un sistema de montaje adecuado para su sistema de altavoz y su aplicación prevista. Recomendamos que utilice accesorios de montaje de Bose si están disponibles. Un ingeniero profesional licenciado debe revisar el diseño y la fabricación de todos los componentes físicos personalizados para la instalación.
- Los altavoces modulares ShowMatch incluyen un sistema de montaje de conexión rápida diseñado para facilitar el trabajo de los instaladores profesionales. Las conexiones modulares se deben realizar solo con las barras de conexión de montaje y las sujeciones de conexión rápida de carga incluidos u opcionales. No se deben utilizar sujeciones sin marcas (no aptas para soportar cargas).
- No utilice las asas como puntos de fijación para suspender el altavoz. Las asas NO están diseñadas para soportar la carga.
- Utilice un cable de seguridad, unido de forma independiente al gabinete, en un punto distinto del punto de fijación de la carga del sistema de montaje del altavoz. Esto se recomienda incluso si la reglamentación local no lo requiere. Consulte a un ingeniero profesional licenciado o a profesionales de andamiaje para realizar un diseño y una instalación adecuados.
- Bajo ninguna circunstancia trepe el arreglo.

Consultez attentivement cette notice d'installation et conservez-la pour toute référence future.

L'installation de ce produit doit être effectuée par un technicien professionnel ! Ce document à l'intention des installateurs professionnels contient les directives de pose et de sécurité relatives à ce produit en installation fixe ou dans des applications portables. Veuillez lire ce document, ainsi que l'ensemble des avertissements de sécurité avant de procéder à l'installation.

AVERTISSEMENTS:



- Tous les produits Bose® doivent être installés dans le respect des réglementations professionnelles, locales et nationales. L'installateur est responsable du respect de tous les codes et règlements locaux et nationaux en vigueur applicables à l'installation et au montage des enceintes. Consultez les autorités locales compétentes avant d'installer ce produit.
- Tout montage non sécurisé d'une lourde charge peut provoquer des dégâts matériels et des blessures graves, voire la mort. Il en va de la responsabilité de l'installateur d'évaluer la fiabilité de la méthode de montage utilisée, en fonction de l'application. Seul un installateur professionnel connaissant les accessoires et techniques de montage adaptés est qualifié pour installer des enceintes suspendues.

ATTENTION:



- Une fois installées, les systèmes d'enceintes doivent faire l'objet d'une inspection et d'un entretien préventif afin d'assurer un fonctionnement en toute sécurité. Vérifiez que les composants et les points de fixation ne portent pas de traces de corrosion, de déformations ou autre signe de détérioration de leur intégrité structurelle. Remplacez immédiatement tout composant usé ou endommagé.
- Toute modification non autorisée peut compromettre votre sécurité, le respect des réglementations et le bon fonctionnement de l'appareil, et en invalidera la garantie.
- Ne connectez pas plus de 24 modules ShowMatch complets ou 18 caissons de basses ShowMatch au moyen du système de suspension intégré. Veuillez vous reporter à l'étiquetage des produits pour connaître les limites de charge.

Note: Toujours utiliser le logiciel Bose Modeler® ou «Bose Array Tool» pour confirmer les limites sécuritaires d'accrochage ainsi que configurations, angles d'orientation et points de connexion.

Instruction d'installation et de configuration du module d'enceintes ShowMatch

Les directives d'installation contenues dans le présent document ne représentent que des conseils généraux et, à ce titre, ne présentent pas tous les critères et précautions de rigueur. En conséquence, toute personne utilisant ce document assume seule l'entière responsabilité de la sécurité d'installation de toutes les enceintes et de la configuration pratique de leur montage.

- Avant l'installation d'un système portable ou d'une enceinte suspendue, il est nécessaire de faire approuver par un professionnel dûment autorisé l'emplacement et la méthode de fixation à la structure du bâtiment et de lui faire confirmer que cette fixation est conforme au code du bâtiment et aux réglementations. Il est important de s'assurer que la surface de montage et la méthode de fixation des enceintes à cette surface sont adaptées au poids total du système. Par sécurité, il est recommandé de respecter un rapport de poids de 10:1.
- Tous les composants du système de montage doivent provenir d'un fabricant de bonne réputation. Le système de montage choisi doit être adapté aux enceintes et à l'utilisation prévue. Il est recommandé d'utiliser les accessoires de montage Bose disponibles. Faire contrôler par un professionnel qualifié la conception et la fabrication des accessoires de montage sur mesure.
- Le module d'enceintes Array Bose ShowMatch est doté d'un système de suspension par goupilles « quick pin » intégré, destiné à en faciliter le montage par un installateur professionnel. Les connexions entre modules doivent être réalisées uniquement au moyen des barres de suspension intégrées, avec les goupilles « quick pin » résistantes à la charge fournies ou en option. Veillez à ne pas utiliser de fixations dont la classe de résistance à la charge n'est pas indiquée.
- Ne pas utiliser les poignées de transport des enceintes comme points de suspension. Ces poignées ne sont pas conçues pour supporter une charge permanente!
- Fixer un câble de sécurité, attaché séparément au coffret de l'enceinte, en un point autre que les points de fixation du système de montage de l'enceinte. Cette mesure est recommandée, même si elle n'est pas imposée par la réglementation locale. Pour la conception et la réalisation de l'installation, consulter un professionnel agréé.
- Ne monter sur le système en aucune circonstance.

Bitte lesen Sie diese Montageanleitung sorgfältig durch und bewahren Sie sie zum späteren Nachschlagen auf.

Dieses Produkt darf nur von fachkundigen Monteuren installiert werden! Dieses Dokument soll fachkundigen Monteuren grundlegende Installations- und Sicherheitsrichtlinien für dieses Produkt in mobilen und festinstallierten Anwendungen bieten. Bitte lesen Sie dieses Dokument und alle Sicherheitshinweise vor der Installation durch.

WARNUNG:

- Alle Produkte von Bose müssen gemäß lokalen und gesetzlichen Vorschriften sowie gemäß allen Branchenbestimmungen installiert werden. Der Monteur ist dafür verantwortlich, sicherzustellen, dass die Installation der Lautsprecher und der Halterung gemäß allen geltenden Vorschriften durchgeführt wird, einschließlich örtlicher Bauvorschriften und -bestimmungen. Wenden Sie sich vor der Installation dieses Produkts an die zuständige abnehmende Behörde.
- Eine unsichere Befestigung schwerer Lasten oder deren Aufhängung über Kopf kann zu schweren oder tödlichen Verletzungen und Sachschäden führen. Der Monteur ist dafür verantwortlich, die Zuverlässigkeit der für die Anwendung verwendeten Befestigungstechniken zu prüfen. Nur fachkundige Monteure mit Wissen über sachgemäße Befestigungselemente und sichere Befestigungstechniken sollten Lautsprecher über Kopf installieren.

VORSICHT:

- Installierte Lautsprecher erfordern regelmäßige Überprüfung und Routinewartung, um die ordnungsgemäße Funktion und den sicheren Betrieb zu gewährleisten. Überprüfen Sie die Befestigungselemente und das Zubehör auf Anzeichen von Korrosion, Verbiegen oder andere Anzeichen, die die mechanische Stabilität verringern können. Ersetzen Sie abgenutzte oder beschädigte Teile sofort.
- Keine nicht autorisierten Veränderungen am Produkt vornehmen. Diese können die Sicherheit, die Einhaltung von Richtlinien und die Systemleistung beeinträchtigen. In diesem Fall kann die Garantie ungültig werden.
- Nutzen Sie das integrierte Array-Verankerungssystem niemals für mehr als 24 ShowMatch Fullrange-Module bzw. 18 ShowMatch Subwoofer-Module. Angaben zur zulässigen Traglast entnehmen Sie bitte dem Typenschild.

Anmerkung: Verwenden Sie immer die Bose Modeler[®] Software oder die "Bose Array Tool" Software, um die sicheren Lastbedingungen (Safe Working Load Limit) für eine Array-Konfiguration mit gegebenen Neigungswinkeln und Verbindungspunkten zu ermitteln.

Richtlinien für die Montage und Inbetriebnahme von ShowMatch Array Modul Lautsprechern

Die in diesem Dokument enthaltenen Installationsinformationen sind nur eine allgemeine Richtlinie und können daher nicht alle Anforderungen und Vorsichtsmaßnahmen darstellen. Demgemäß übernimmt jeder, der dieses Material verwendet, die gesamte Haftung und ist ausdrücklich verantwortlich für die Sicherheit aller Lautsprecher-Array-Designs und deren Montagetechniken, die in der Praxis eingesetzt werden.

- Vor der Installation oder temporären Inbetriebnahme von Lautsprechern über Kopf muss ein zugelassener fachkundiger Techniker den Ort und die Art der Befestigung an der Gebäude- bzw. Trägerstruktur prüfen und bestätigen, dass diese allen Bauvorschriften und Bestimmungen entspricht. Vergewissern Sie sich, dass die Befestigungsfläche und die Art und Weise der Befestigung des Lautsprechersystems an der Fläche geeignet ist, das Gesamtgewicht des Systems zu tragen. Es wird ein Sicherheitsfaktor von 10:1 empfohlen.
- Beschaffen Sie sich alle Komponenten der Halterung von zertifizierten Herstellern. Wählen Sie eine Halterung, die für Ihr Lautsprechersystem und die beabsichtigte Anwendung geeignet ist. Wir empfehlen Befestigungszubehör von Bose, sofern verfügbar. Ein zugelassener fachkundiger Techniker muss die Auslegung und die Herstellung der benutzerspezifischen Befestigungselemente überprüfen.
- Bose ShowMatch Array Modul Lautsprecher verfügen über integrierte Montagepunkte mit Schnellverschlüssen, was die Installation des Lautsprecher-Arrays durch fachkundige Monteure erleichtern soll. Die Module dürfen untereinander ausschließlich mit den integrierten Verbindungsstangen sowie den im Lieferumfang enthaltenen bzw. optional erhältlichen und für die Last zugelassenen Schnellverschlüssen verbunden werden. Nicht gekennzeichnete (nicht für das Tragen von Lasten geeignete) Befestigungselemente dürfen nicht verwendet werden.
- Hängen Sie die Lautsprecher nicht mithilfe von Griffen als Befestigungspunkte auf. Griffe sind NICHT als Montagepunkte vorgesehen.
- Bringen Sie ein zusätzliches Sicherheitsseil an der Box an. Verwenden Sie hierzu nicht die tragenden Befestigungspunkte, die die Halterung mit dem Lautsprecher verbinden. Wir empfehlen diese Sicherheitsmaßnahme auch dann, wenn diese von den örtlichen Behörden nicht vorgeschrieben ist. Wenden Sie sich wegen der sachgemäßen Auslegung und Installation an einen zugelassenen fachkundigen Techniker oder ein Fachunternehmen.
- Besteigen Sie unter keinen Umständen das Array.

Introduction

ShowMatch™ DeltaQ™ Array Loudspeaker Introduction 7
 ShowMatch DeltaQ Array Modules 7
 Module Optional Accessories 7
 Array Frame Accessories 7

Technical Specifications

Product Dimensions..... 8
 ShowMatch SM5 8
 ShowMatch SM10..... 8
 ShowMatch SM20..... 9
 ShowMatch SM118 9
Working Load Limits 10
 ShowMatch Full-Range Modules 10
 ShowMatch Subwoofer..... 10
Connector Wiring..... 11
Array Rigging..... 11
 Painting the Enclosure 11
Recommended Amplifier Power 12
Recommended Signal Processing 12
Array Design Software Tools..... 13
 Bose Modeler 13
 Bose Array Tool..... 13
Additional Product Information..... 13
ShowMatch DeltaQ Array Loudspeakers Technical Specifications..... 14

Additional Resources

Contact Information..... 15
 Importer Information 15
Limited Warranty 15

Please complete and retain for your records. Serial and model numbers are located on the rear panel of the loudspeakers.
Serial number: _____
Model number: _____

ShowMatch™ DeltaQ™ Array Loudspeaker Introduction

Thank you for selecting Bose® ShowMatch DeltaQ Array loudspeakers. This document contains important information regarding the setup and operation of this product. For additional information and to confirm the latest version of this document, please refer to the pro.Bose.com website.

Bose ShowMatch loudspeakers use DeltaQ next-generation array technology with field-changeable horizontal coverage patterns to maximize versatility and improve overall sound quality. Compact, lightweight enclosures are available in 5°, 10°, and 20° vertical coverage patterns, and feature removable side caps that optimize both installation and portable/tour-sound applications. With unprecedented flexibility, ShowMatch modules can form DeltaQ arrays, constant curvature, or traditional “J-array” configurations to maximize performance for a wide range of audience areas and budgets. Matching subwoofer and rigging accessories complete the ShowMatch product line.

ShowMatch DeltaQ Array Modules

ShowMatch SM5 full-range module with 5° vertical coverage. Ships with 70° horizontal waveguide installed and includes 100° waveguide panels. Change single panel for asymmetrical coverage. Optional accessory: 55° horizontal waveguide.

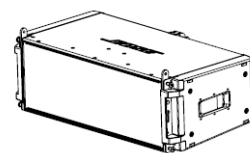

ShowMatch SM10 full-range module with 10° vertical coverage. Ships with 100° horizontal waveguide installed and includes 70° waveguide panels. Change single panel for asymmetrical coverage.

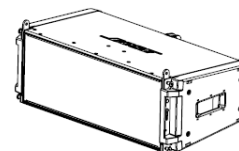

ShowMatch SM20 full-range module with 20° vertical coverage. Ships with 100° horizontal waveguide installed and includes 70° waveguide panels. Change single panel for asymmetrical coverage. Optional accessory: 120° horizontal waveguide.

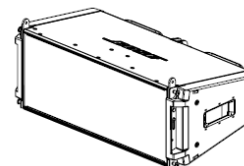

ShowMatch SMS118 subwoofer module with single 18-inch transducer. Enclosure width and rigging are designed to integrate with full-range modules. Rigging also allows front-facing or rear-facing positions for cardioid array configurations. SMS118 subwoofer also includes top pole-mount adapter and integrated M8 threaded inserts to allow use with non-ShowMatch loudspeakers.

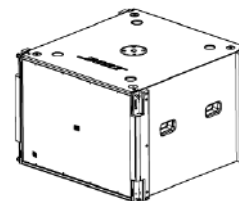

Module Optional Accessories



ShowMatch SM5WG5
55° waveguides for SM5



ShowMatch SM20WG12
120° waveguides for SM20



ShowMatch SMQPS
Module short pins for installs

Array Frame Accessories

For information on the ShowMatch DeltaQ array frame accessories, please refer to the ShowMatch DeltaQ Array Rigging Frames document available online at pro.Bose.com.

Product Dimensions

ShowMatch SM5

Product net weight: 30.6 kg (67.5 lbs)

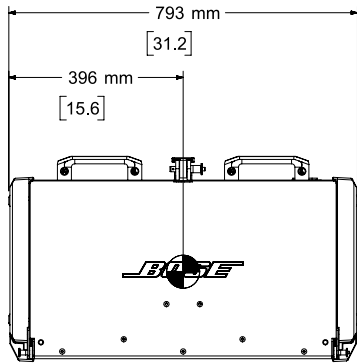

Top View

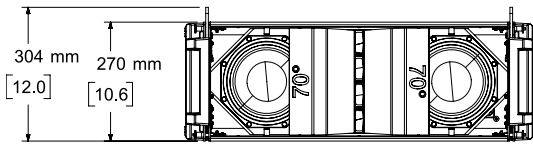

Front View

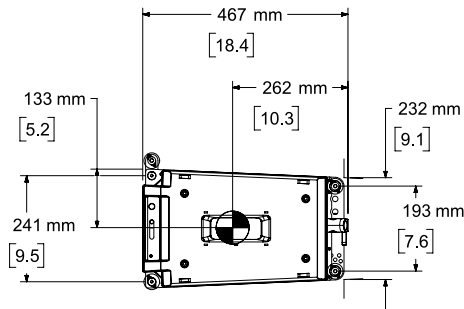

Right View

DIMENSIONS APPLY TO BOTH SIDES

ShowMatch SM10

Product net weight: 29.7 kg (65.5 lbs)

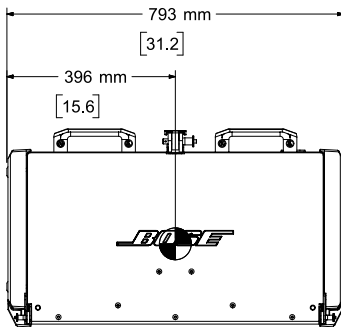

Top View

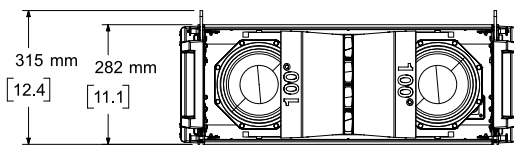

Front View

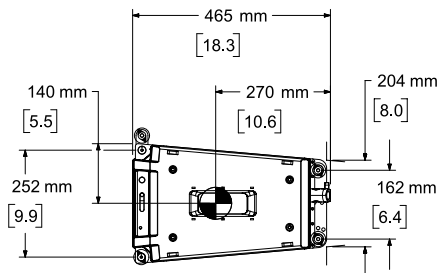

Right View

DIMENSIONS APPLY TO BOTH SIDES

ShowMatch SM20

Product net weight: 29.0 kg (64.0 lbs)

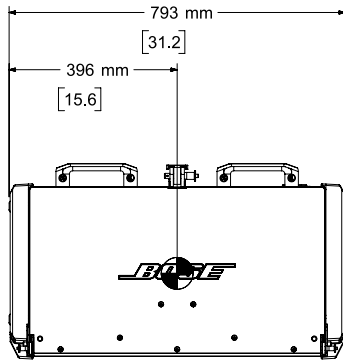

Top View

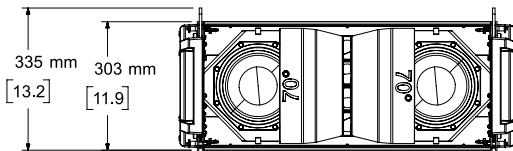

Front View

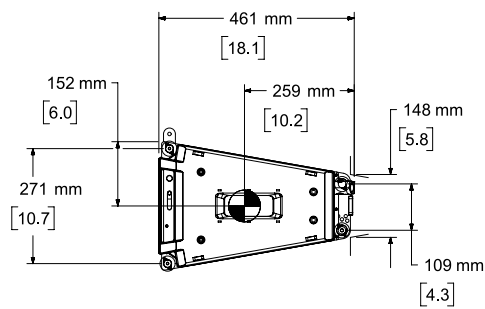

Right View

DIMENSIONS APPLY TO BOTH SIDES

ShowMatch SMS118

Product net weight: 61.9 kg (136.5 lbs)

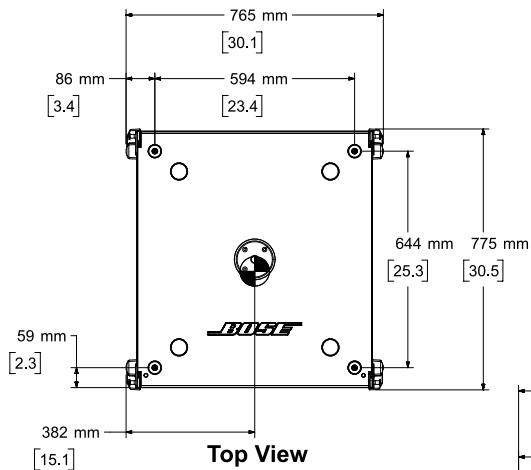

Top View

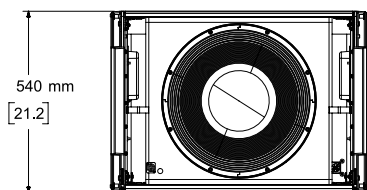

Front View

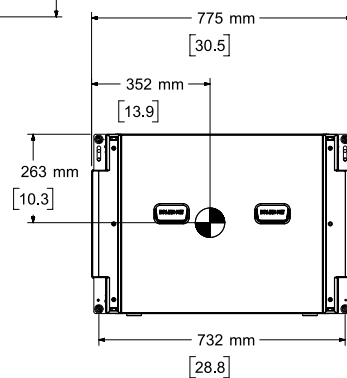

Right View

DIMENSIONS APPLY TO BOTH SIDES

Working Load Limits

All values listed are per point.

ShowMatch Full-Range Modules (SM5, SM10, SM20)

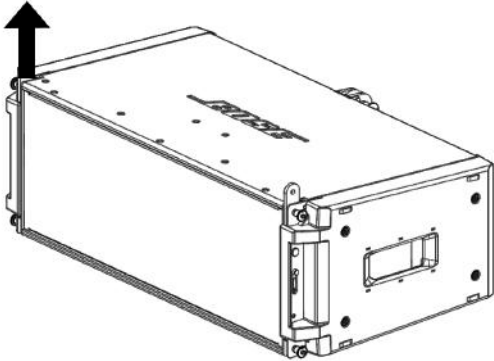

Front Rigging: WLL = 800 lbs (360 kg)

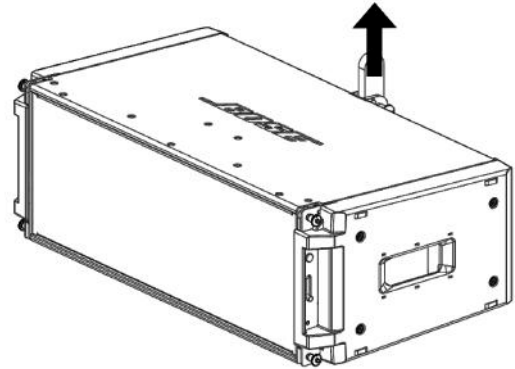

Rear Rigging: WLL = 2300 lbs (1040 kg)

ShowMatch Subwoofer (SMS118)

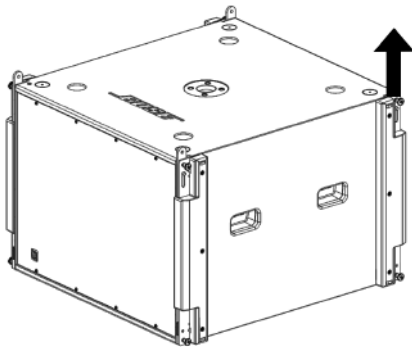

Integrated Rigging: WLL = 800 lbs (360 kg)
(front or rear)

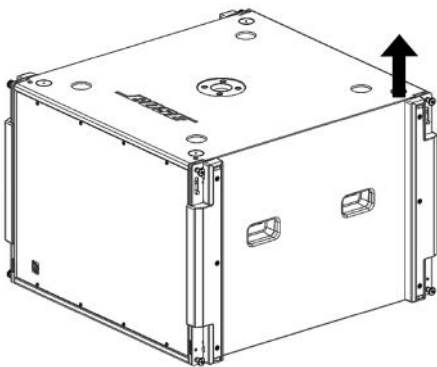

Threaded Inserts: WLL = 200 lbs (90 kg)
(4x top and 4x bottom)
Note: Use with custom installation rigging

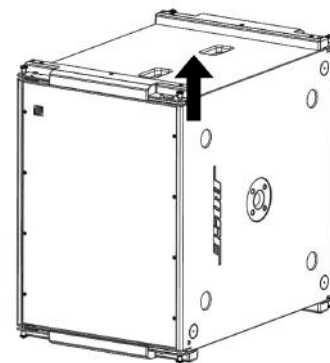

Threaded Inserts: WLL = 200 lbs (90 kg)
(Use swivel and pivot hoist rings; no eyebolts)
Note: Use with custom installation rigging

Connector Wiring

ShowMatch full-range and subwoofer modules are each equipped with two (2) Neutrik® NL4 connectors wired in parallel to allow loop-through connections. Full-range module connectors are wired to provide separate amplifier channels to the high-frequency (HF) and low-frequency (LF) transducers. See table below.

Full-Range		Subwoofer	
NL4 Pin	Driver Section	NL4 Pin	Driver Section
1+	LF drivers - positive	1+	sub - positive
1-	LF drivers - negative	1-	sub - negative
2+	HF drivers - positive	2+	not used
2-	HF drivers - negative	2-	not used



Array Rigging

ShowMatch DeltaQ array loudspeakers are shipped with integrated link-bar rigging hardware. The rigging system is designed to allow fast setup of typical concert-touring or fixed-installation arrays of up to 24 full-range or 18 subwoofer modules while maintaining a 10:1 Safety Factor when used with optional Bose® ShowMatch Array Frame Rigging Accessories.

Note: Always confirm safe working load limits with exact array configurations, pitch angles, and connection points using either Bose Modeler® or Bose Array Tool software.

For details on installing ShowMatch modules to array frames, please refer to the ShowMatch DeltaQ Array Rigging Frames document, which is included in the package of array frames and is also available for download at pro.Bose.com.

Note: Bose ShowMatch loudspeakers and rigging accessories are intended for installation by professional installers only!

Note: All lifting operations require two individuals positioned on each side of the loudspeaker.

Painting the Enclosure

ShowMatch modules, with the end caps removed, can be painted using a solvent-based spray paint such as KRYLON®. For best results, ensure the surface is dry and free of oils and debris. Always test a small inconspicuous area before spraying the entire product. Remove grills and paint separately. Verify that paint does not clog perforations in metal grill. Mask woofers, manifold slots, and rear input panel to ensure paint does not cover these areas.

Recommended Amplifier Power

ShowMatch full-range modules require two (2) amplifier channels with external DSP active crossover filters (modules contain no passive crossover network). Each module contains series-parallel connections of four (4) compression drivers delivering nominal 6-ohm impedance, with long-term power-handling rating of 100 watts and peak rating of 400 watts. The low-frequency section contains parallel connections of two (2) woofers delivering nominal 8-ohm impedance, with long-term power-handling rating of 450 watts and peak rating of 1800 watts.

ShowMatch subwoofer modules contain a single 18-inch woofer with nominal 4-ohm impedance, with long-term power rating of 750 watts and peak rating of 3000 watts.

Selecting the proper amplifier size for a given loudspeaker requires analysis of the transducer long-term (or RMS) power rating, dynamic range of the input-source material (crest factor), desired sound pressure levels, and other factors. As a general guideline, to optimize ShowMatch system performance, the following amplifier configurations are recommended.

Module	Nominal Impedance	Amp Channel	Amp Power Rating
Full-Range, LF	8 ohms	1	500 to 1800 watts
Full-Range, HF	6 ohms	2	200 to 400 watts
Subwoofer	4 ohms	3	1000 to 3000 watts

The Bose® PowerMatch® PM8500 Professional Amplifier (sold separately) is easily configured to provide the recommended amplifier power for ShowMatch modules and arrays. The PM8500 also provides presets for all recommended signal processing, including active crossover, EQ, alignment delay, protection limiting, array-compensation EQ settings, and cardioid subwoofer settings when used with the ShowMatch SMS118 subwoofer.

Recommended Signal Processing

Digital signal processing (DSP) equipment is required for infrasonic protection, crossover, equalization, and protection limiting functions. The recommended active crossover for the ShowMatch full-range modules uses the following filters in the Bose PowerMatch PM8500 professional amplifier or Bose ControlSpace® ESP (sold separately).

Full-Range Module Applications (for use without subwoofers)

Driver Elements	High-Pass Filter			Low-Pass Filter		
	Type	Slope	Frequency	Type	Slope	Frequency
Module LF	Butterworth	12 dB/octave	70 Hz	Butterworth	24 dB/octave	750 Hz
Module HF	Butterworth	24 dB/octave	800 Hz	none	none	none

Full-Range Module with Subwoofer Applications

Driver Elements	High-Pass Filter			Low-Pass Filter		
	Type	Slope	Frequency	Type	Slope	Frequency
Subwoofer SMS118	Butterworth	24 dB/octave	30 Hz	Butterworth	24 dB/octave	80 Hz
Module LF	Butterworth	12 dB/octave	70 Hz	Butterworth	24 dB/octave	750 Hz
Module HF	Butterworth	24 dB/octave	800 Hz	none	none	none

Array Design Software Tools

Bose® Modeler®

For complete room acoustic simulation with direct and reverberant-field mapping.

ShowMatch array modules allow thousands of array configurations based on room dimensions, acoustics, and level requirements. Additionally, the coverage pattern for lower frequencies varies with the number of modules in the array. Therefore, the use of Bose Modeler software is recommended for the design of ShowMatch arrays in a specific venue.

Bose Modeler software is an acoustic design and analysis program for sound system designers or acoustical consultants. Using a computer-based 3D model of the acoustic space and advanced acoustic ray tracing algorithms, Modeler can predict the acoustic performance of loudspeaker systems in a specific venue using both direct and reflected sound calculations. Modeler software has been a leader in sound system performance prediction for more than 25 years and was the first software to provide predictions for Sound Transmission Index (STI), a measure of speech intelligibility and quality.

Modeler software (Version 6.9 or higher) includes an array design tool optimized to help designers construct progressive directivity arrays using ShowMatch modules.

For additional information on using the ShowMatch Array Design Tool, please refer to the Help system in Modeler software or the Modeler Software User's Guide available online at pro.Bose.com.

Bose Array Tool

Fast, easy, direct-field-only coverage mapping.

The Bose Array Tool provides fast, easy modeling of array performance and target audience area coverage, when only direct-field simulation is required. It does not account for room reflections or predict STI scores. Bose Array Tool design files may be imported into Bose Modeler for complete direct plus reverberant model predictions.

Additional Product Information

For more information and complete installation instructions for ShowMatch DeltaQ loudspeaker modules and compatible accessories, refer to the installation guide available at pro.Bose.com. To request a printed copy, use the phone numbers provided in the Contact Information section of this guide.

ShowMatch™ DeltaQ™ Array Loudspeakers Technical Specifications

Single Module Performance	Common for All Full-Range Modules						SMS118	
Frequency Response (+/- 3 dB) ⁽¹⁾	70 - 17,000 Hz						32 - 250 Hz	
Frequency Range (-10 dB)	60 - 17,000 Hz						29 - 300 Hz	
Transducers								
Low Frequency	2 x Bose SM8 neodymium 8-inch woofers (3-inch voice coil)						1 x 18" neodymium woofer (4.5 inch voice coil)	
High Frequency	4 x Bose EMB2S extended-HF neodymium compression driver (2-inch voice coil)						none	
Nominal Impedance	8 ohms + 6 ohms (LF/HF)						4 ohms	
Recommended Crossover	800 Hz (acoustic; requires active 2-way crossover in DSP)						70 Hz for ShowMatch	
Recommended High-Pass Protection Filter	70 Hz with minimum 12 dB / octave filter						30 Hz with minimum 12 dB / octave filter	
	Low Frequency			High Frequency				
Power Handling, long-term continuous	450 W			100 W			750 W	
Power Handling, peak	1800 W			400 W			3000 W	
Enclosure								
Enclosure Material	Baltic birch plywood						Baltic birch plywood	
Finish	Two-part spray polyurethane coating, black						Two-part spray polyurethane coating, black	
Grill	16-gauge (1.5 mm) perforated steel, powder-coated finish, black						16-gauge (1.5 mm) perforated steel, powder-coated finish, black	
Environmental	IPx4						IPx4	
Connectors	2 x Neutrik® NL4 wired parallel						2 x Neutrik® NL4 wired parallel	
Suspension / Mounting	Integrated 3-point quick-pin rigging						Integrated 4-point quick-pin rigging	
	SM5		SM10		SM20			
Nominal Coverage Pattern	70°H x 5°V (or 100°H; optional 55°H)		100°H x 10°V (or 70°H)		100°H x 20°V (or 70°H; optional 120°H)		omni with cardioid array configurations	
	Low Frequency	High Frequency	Low Frequency	High Frequency	Low Frequency	High Frequency	Array (free field)	Ground Stack
Sensitivity (SPL / 1W @ 1m) ⁽²⁾	94 dB	106 dB	94 dB	105 dB	94 dB	104 dB	94 dB	100 dB
Calculated Maximum SPL @ 1 m ⁽³⁾	121 dB	126 dB	121 dB	125 dB	121 dB	124 dB	123 dB	129 dB
Calculated Maximum SPL @ 1 m, peak	127 dB	132 dB	127 dB	131 dB	127 dB	130 dB	129 dB	135 dB
Dimensions (H x W x D) - mm	270 x 793 x 467 mm / W: 757 mm ⁽⁵⁾		282 x 793 x 465 mm / W: 757 mm ⁽⁵⁾		303 x 793 x 461 mm / W: 757 mm ⁽⁵⁾		540 x 765 x 775 mm / W: 757 mm ⁽⁵⁾	
Dimensions (H x W x D) - inches	10.6 x 31.2 x 18.4" / W: 29.8" ⁽⁵⁾		11.1 x 31.2 x 18.3" / W: 29.8" ⁽⁵⁾		11.9 x 31.2 x 18.1" / W: 29.8" ⁽⁵⁾		21.2 x 30.1 x 30.5" / W: 29.8" ⁽⁵⁾	
Net Weight	30.6 kg (67.5 lbs)		29.7 kg (65.5 lbs)		29.0 kg (64.0 lbs)		61.9 kg (136.5 lbs)	

Footnotes

- (1) Frequency response and range measured on-axis in anechoic environment with recommended bandpass and EQ
- (2) Bose extended-lifecycle test using pink noise filtered to meet IEC268-5, 6 dB crest factor, 500 hour duration
- (3) Sensitivity measured in anechoic environment with recommended bandpass and EQ
- (4) Maximum SPL calculated from sensitivity and power handling specifications, exclusive of power compression
- (5) Width dimensions with side caps removed

Contact Information

Visit us on the web at pro.Bose.com.

Americas

(USA, Canada, Mexico, Central America, South America)
Bose Corporation
The Mountain
Framingham, MA 01701 USA
Corporate Center: 508-879-7330
Americas Professional Systems,
Technical Support: 800-994-2673

Australia

Bose Pty Limited
Unit 3/2 Holker Street
Newington NSW Australia
TEL 61 2 8737 9999

Belgium

Bose N.V. / S.A
Limesweg 2, 03700
Tongeren, Belgium
TEL (32) 012-390800

China

Bose Electronics (Shanghai) Co Ltd
36F, West Gate Tower
1038 West Nanjing Road
Shanghai, P.R.C. 200041 China
TEL 86 21 6271 3800

France

Bose S.A.S
12 rue de Temara
78100 St. Germain en Laye, France
TEL 01-30-61-63-63

Germany

Bose GmbH
Max-Planck Strasse 36D 61381
Friedrichsdorf, Deutschland
TEL 06172-7104-0

Hong Kong

Bose Limited
Suites 2101-2105, Tower One, Times Square
1 Matheson Street, Causeway Bay, Hong Kong
TEL 852 2123 9000

India

Bose Corporation India Private Limited
Salcon Aurum, 3rd Floor
Plot No. 4, Jasola District Centre
New Delhi - 110025, India
TEL 91 11 43080200

Italy

Bose SpA
Centro Leoni A - Via G. Spadolini
5 20122 Milano, Italy
TEL 39-02-36704500

Japan

Bose Kabushiki Kaisha
Shibuya YT Building
28-3 Maruyama-sho
Shibuya-Ku, Tokyo, 150, Japan
TEL 81-3-5489-0955
www.bose.co.jp

The Netherlands

Bose BV
Nijverheidstraat 8 1135 GE
Edam, Nederland
TEL 31 (0)299-390139

United Kingdom

Bose House
Quayside Chatham Maritime
Chatham, Kent ME4 4QZ, United Kingdom
TEL 44 (0)3330-142545

See website for other countries

Importer Information

European Union

Bose GP, Castleblayney Road, Carrickmacross, County Monaghan, Ireland

China

Bose Electronics (Shanghai) Company Limited, Part C, Plan 9, No. 353 North Riyang Road, China (Shanghai)
Pilot Free Trade Zone

Taiwan

Bose Taiwan Branch, 9F-A1, No. 10, Section 3, Minsheng East Road, Taipei City 104, Taiwan
Tel: 886 2 2514 7977

Mexico

Bose de México, S. de R.L. de C.V., Paseo de las Palmas 405-204, Lomas de Chapultepec, 11000 México, D.F.
Tel: 001 800 900 2673

Limited Warranty

Your product is covered by a limited warranty. Visit pro.Bose.com for warranty details.

The warranty information provided with this product does not apply in Australia and New Zealand. See our website at www.bose.com/au/warranty or www.bose.com/nz/warranty for details of the Australia and New Zealand warranty.

NEUTRIK® is a registered trademark of Neutrik AG.

KRYLON® is a registered trademark of SWIMC, Inc.



773791-0010

©2016 Bose Corporation, The Mountain,
Framingham, MA 01701-9168 USA
AM773791 Rev. 00

