

**CGN 99 C/S**

**CGN 99 C/L**

**CGN 99 H/S**

**CGN 99 H/L**

**CHM 99**

**USER INSTRUCTIONS**

Please read the manual before using the equipment!





## 1 Safety and Environment

1. Do not spill any liquids on the equipment and do not drop any objects through the ventilation slots in the equipment.
2. Do not place the equipment near heat sources such as radiators, heating ducts, or amplifiers, etc. and do not expose it to direct sunlight, excessive dust, moisture, rain, mechanical vibrations, or shock.
3. The packaging of the equipment is recyclable. To dispose of the packaging, make sure to use a collection/recycling system provided for that purpose and observe local legislation relating to waste disposal and recycling.



## 2 Description

### 2.1 Introduction

Thank you for purchasing a Discreet Acoustics module. The **Discreet Acoustics Compact Series** comprises four gooseneck microphones, one flown microphone, and dedicated accessories for every application and every type of venue.

### 2.2 Microphones

Refer to figs. 9 to 14.

**CGN 99 C/S (order no. 2965H00110):** 380-mm (15-in.) cardioid gooseneck microphone with integrated DPA XLR phantom power adapter and external foam windscreen.

**CGN 99 H/S (order no. 2965H00120):** 380-mm (15-in.) hypercardioid gooseneck microphone with integrated DPA XLR phantom power adapter and external foam windscreen.

**CGN 99 C/L (order no. 2965H00130):** 576-mm (23-in.) cardioid gooseneck microphone with integrated DPA XLR phantom power adapter and external foam windscreen.

**CGN 99 H/L (order no. 2965H00140):** 576-mm (23-in.) hypercardioid gooseneck microphone with integrated DPA XLR phantom power adapter and external foam windscreen.

**CHM 99 (order no. 2965H00150):** cardioid flown microphone with spring clamp and 10-m (33-ft.) special cable with DPA XLR phantom power adapter.

## 2 Description



Always use the supplied windscreen (unless it would be too visually obtrusive). It protects the microphone from dust and moisture, and reduces pop and wind noise to a minimum.

---

**2.3 Windscreen**  
(2965Z2001)

**B 18 battery power supply** for all Discreet Acoustics Compact microphones.

**2.4 Optional Accessories**

**PS3 F-Lock panel mount socket** for all Discreet Acoustics Compact gooseneck microphones (not for CHM 99).

Refer to fig. 9.

**H 500 shock mount** for all Discreet Acoustics Compact gooseneck microphones (not for CHM 99).

Refer to fig.10.

**H 600 shock mount** for all Discreet Acoustics Compact gooseneck microphones (not for CHM 99).

Refer to fig.11.

**SA 60 stand adapter** for all Discreet Acoustics Compact gooseneck microphones (not for CHM 99).

Refer to fig.12.

**ST 1, ST 45 table stands** for all Discreet Acoustics Compact gooseneck microphones (not for CHM 99).

---

Refer to fig.13.

## 3 Microphone Applications



Note that both the maximum working distance and the area covered by the microphone depend on the pickup angle. The smaller the pickup angle (hypercardioid), the longer the maximum distance between the talker and the microphone and the smaller the area covered by the microphone.

Refer to Table 1.

Whether a cardioid or hypercardioid capsule will give the best results therefore depends on the specific application situation).



## 3 Microphone Applications

Microphone	Polar Pattern	Speaker position	Working distance	Application
CGN 99 C/S	Cardioid	Behind the microphone only	30 to 60 cm* (1 to 2 feet)	Sound system
CGN 99 H/S	Hypercardioid	90° to 135° off microphone axis	30 to 90 cm* (1 to 3 feet)	Sound system
CGN 99 C/L	Cardioid	Behind the microphone only	30 to 60 cm* (1 to 2 feet)	Sound system
CGN 99 H/L	Hypercardioid	90° to 135° off microphone axis	30 to 90 cm* (1 to 3 feet)	Sound system
CHM 99	Cardioid	Behind the microphone only	1 to 3 m* (3.5 to 10 feet)	Sound system

**Table 1: Microphone applications.**

\* Depending upon Acoustic environment

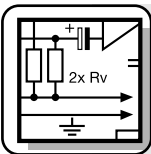

## 4 Installation and Connection

### 4.1 Introduction

All Discreet Acoustics Compact microphones are condenser microphones and therefore require a power supply (phantom power). The microphones have been designed for connection to microphone inputs with 9 to 52 V phantom power. To connect Discreet Acoustics Compact microphones to inputs without phantom power, refer to Section 4.4.

### 4.2 CGN 99 ... Gooseneck Microphones

Refer to figs. 9 and 12.

#### Note:

Refer to figs. 10 and 11.

For even better vibrational noise rejection, you can fix the microphone to the tabletop with an optional H 500 or H 600 shock mount.

1. Use the optional PS 3 F-Lock panel mount socket to install the microphone in a tabletop or an optional SA 60 stand adapter to mount the microphone on a floor or table stand.
2. Use a shielded cable to connect the microphone to a microphone input with phantom power.

## 4 Installation and Connection

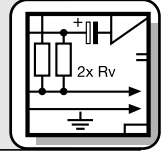

3. If the phantom power on your mixing console is switchable, switch the phantom power on. (Refer to the instruction manual for your mixing console.)  
The microphone is powered directly from the phantom power source on the console.

1. **Prior to installing the microphone**, straighten the cable by carefully pulling it through your fingers. Make sure not to buckle or twist the cable. Let hang for 1 day to untwist.
2. Fasten a hook to the ceiling, use an existing hook, or stretch a fishing line across the hall.
3. Pass the cable through the hook or over the line so that it will hang at the desired height.

### 4.3 CHM 99 Flown Microphone

**Do not tie a knot into the cable to hang it on the hook.** This may cause the cable to twist and misalign the microphone after a while.

**Important!**

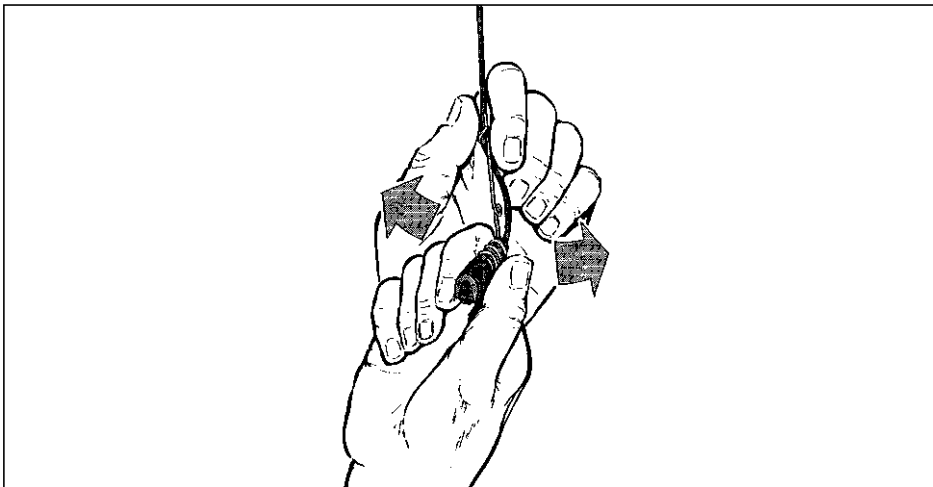

Fig. 1: Aligning the microphone.

5. Hold the cable with one hand and turn the microphone carefully into the desired position.

Refer to fig. 1.

- The cable on the CHM 99 will twist as the ambient temperature changes, e.g., in the heat generated by spotlights.
- The angle of twist depends both on the ambient temperature and the cable length. The shorter the cable, the smaller the amount of twist.

**Note:**

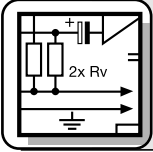

## 4 Installation and Connection

- If you use spotlights, be sure to turn them on before aligning the microphone.
- When you turn the spotlights off, the microphone will rotate out of alignment. Upon turning the spotlights back on, the microphone should rotate back into its original position.

### 4.3.1 Stabilizing the Microphone

To stabilize the microphone,

1. Leave an appropriate length of fishing line through the eyelet on the spring clamp of the CHM 99.
2. Fix the fishing line to two opposite walls so as to create just enough downward pull to steady the microphone laterally.

### 4.3.2 Applications

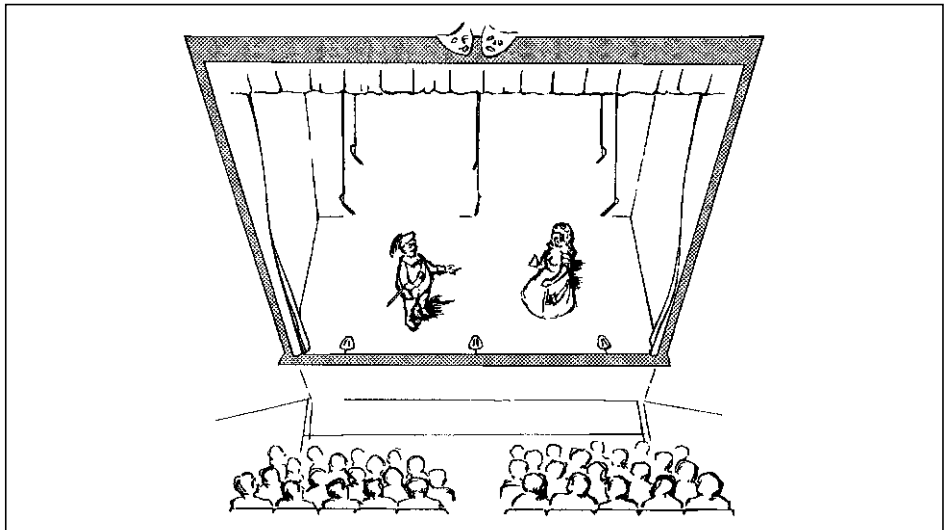

Fig. 2: Theater stage miking

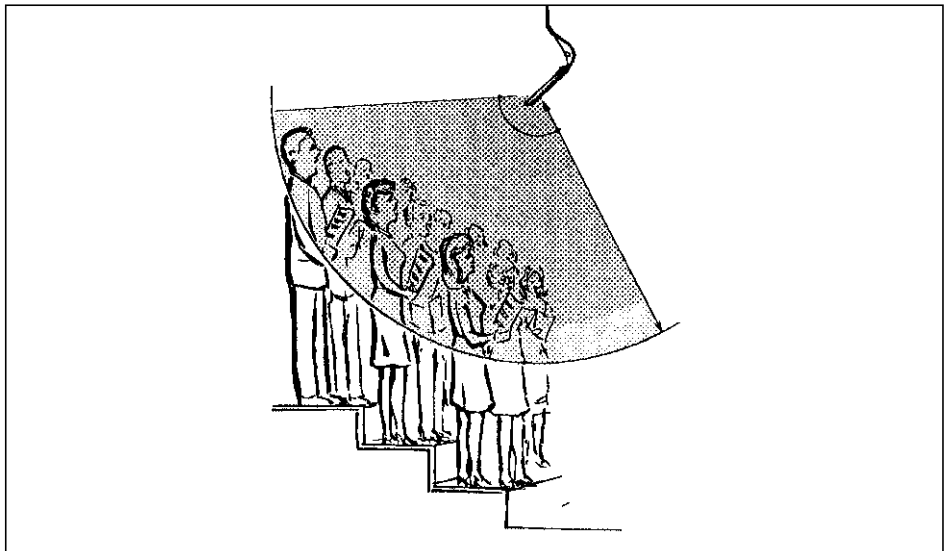
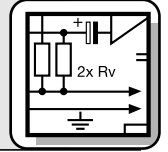

Fig. 3: Miking up a choir

## 4 Installation and Connection



1. Use a shielded balanced cable to connect the microphone to a microphone input with phantom power.
2. If the phantom power on your mixing console is switchable, switch the phantom power on. (Refer to the instruction manual for your mixing console.)  
The microphone is powered directly from the phantom power source.

### 4.3.3 Audio Connection

If your mixer has no phantom power, insert an external phantom power supply between the DPA phantom power adapter and mixer input. We recommend the optional B 18 power supplies from AKG. **Using any power supplies not recommended by AKG may damage your microphone and voids the warranty.**

### 4.4 Connecting to Inputs without Phantom Power

You may also consider having a **qualified technician** retrofit a phantom power supply as per IEC 61938 to balanced or unbalanced mixer inputs. The IEC 61938 standard specifies a positive voltage of 12, 24, or 48 V on the audio lines versus the cable shield.

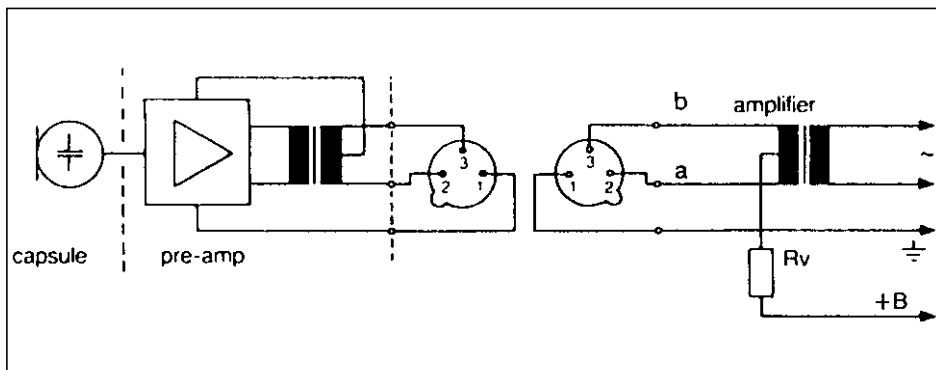

#### 4.4.1 Balanced Inputs

Fig. 4: Input transformer **with center tap** (ungrounded)

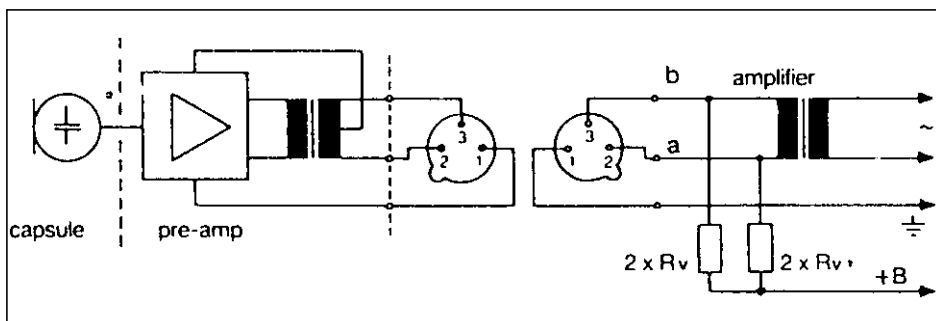
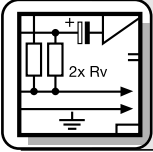

Fig. 5: Input transformer with **no center tap** (ungrounded)

If your equipment inputs are grounded or transformerless, wire either capacitors or extra transformers into the audio lines as shown in fig. 9 above in order to prevent any current leakage into the input stage.



## 4 Installation and Connection

### 4.4.2 Unbalanced Inputs

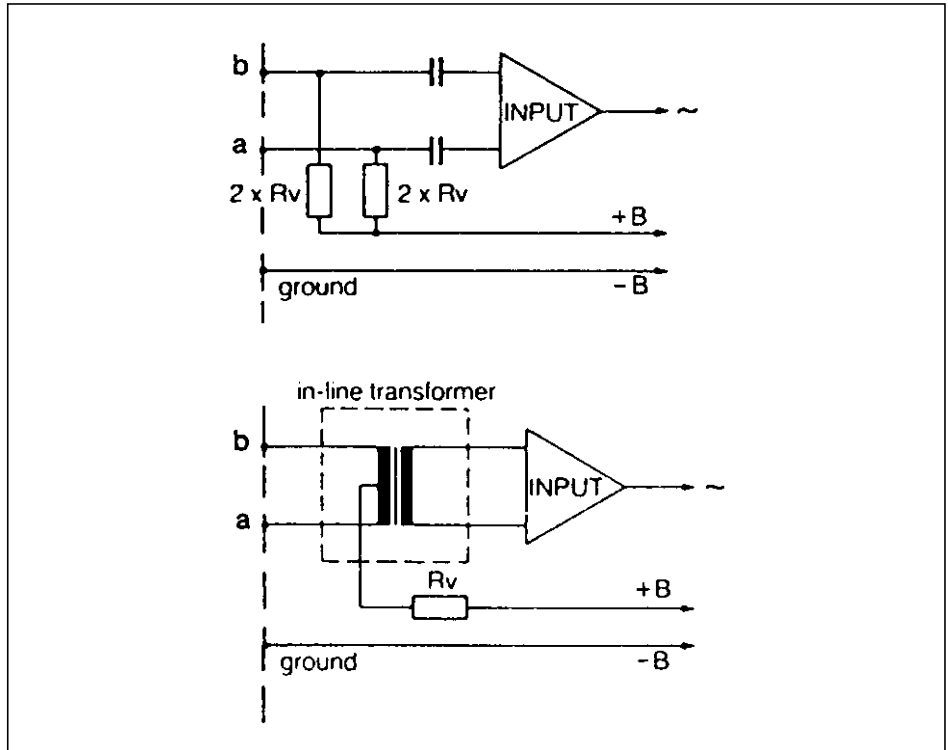

Fig. 6: Unbalanced input stage

Table 2: Standard values for  $R_v$  and  $2 \times R_v$

VDC	$R_v$	$2 \times R_v^*$
12 V $\pm$ 2 V	330 $\Omega$	680 $\Omega$
24 V $\pm$ 4 V	680 $\Omega$	1,200 $\Omega$
48 V $\pm$ 4 V	3,300 $\Omega$	6,800 $\Omega$

\* In order to satisfy the IEC 61938 symmetry requirement, make sure the actual values of the two resistors  $2 \times R_v$  do not differ by more than 0.5%!



## 4 Installation and Connection

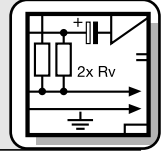

The DPA phantom power adapter is equipped with a bass cut filter to minimize low-frequency noise.

### 4.5 Bass Cut

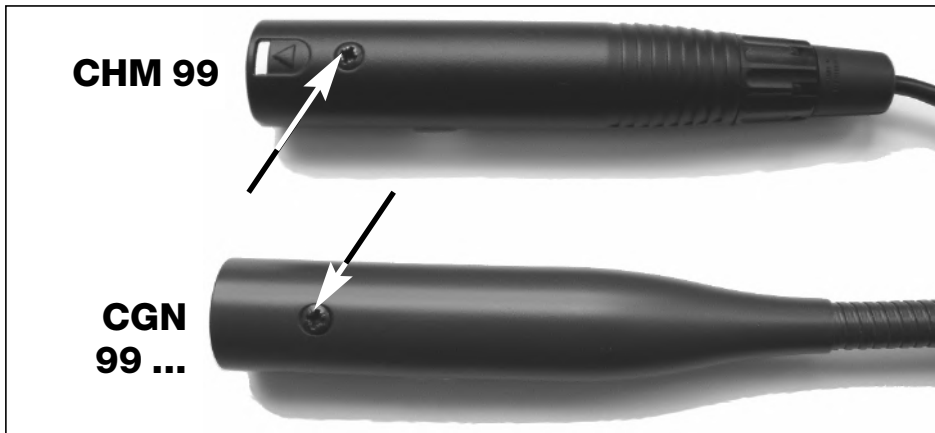

Fig. 7: Fixing screw.

1. Unscrew the fixing screw on the microphone or DPA phantom power adapter.
2. Pull the circuit board out of the case WITH CAUTION – so as not to break the internal leads.

Refer to fig. 7.

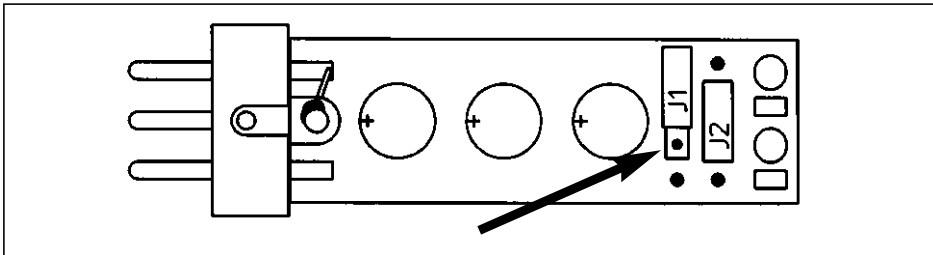

Fig. 8: DPA circuit board.

3. To activate the bass cut filter, plug the jumper J1 into the central contact pair on the circuit board.

Refer to fig. 8.



## 5 Specifications

Microphone	CGN 99 C/S CGN 99 C/L	CGN 99 H/S CGN 99 H/L	CHM 99
Type	Pre-polarized condenser microphone		
Polar pattern	Cardioid	Hypercardioid	Cardioid
Frequency range	70 to 18,000 Hz	50 to 19,000 Hz	70 to 18,000 Hz
Sensitivity	18 mV/Pa △ -35 dBV*	12 mV/Pa △ -38 dBV*	18 mV/Pa △ -35 dBV*
Max. SPL for 1% THD	125 dB	125 dB	125 dB
Equivalent noise level	<21 dB-A	<21 dB-A	<21 dB-A
Signal/noise ratio (A-weighted.)	>73 dB	>73 dB	>73 dB
Electrical impedance	<600 Ω	<600 Ω	<600 Ω
Receommended load impedance	>2000 Ω	>2000 Ω	>2000 Ω
Power requirement	9 to 52 V phantom power to IEC 61938 (DPA adapter integrated)		
Current consumption	<3 mA	<3 mA	<3 mA
Connector	XLR-3	XLR-3	XLR-3
Finish	matte black	matte black	matte black
Size (capsule dia. x length)	13.5 x 380 mm (0.5 x 15 in.) 13.5 x 580 mm (0.5 x 23 in.)	13.5 x 380 mm (0.5 x 15 in.) 13.5 x 580 mm (0.5 x 23 in.)	13.5 x 55 mm (0.5 x 2.1 in.)
Net/shipping weight	160/480 g (5.7/17 oz.) 170/500 g (6/17.7 oz.)	160/480 g (5.7/17 oz.) 170/500 g (6/17.7 oz.)	20/480 g (0.7 x 17 oz.)
Order no.	2965H00110 2965H00130	2965H00120 2965H00140	2965H00150

\* re 1 V/Pa

This product conforms to the standards listed in the Declaration of Conformity. To order a free copy of the Declaration of Conformity, visit <http://www.akg.com> or contact [sales@akg.com](mailto:sales@akg.com).

# 5 Specifications

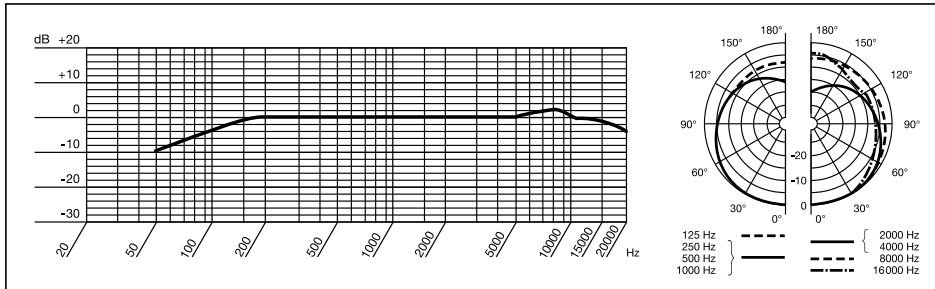

**CGN 99 C/S  
Frequency  
Response &  
Polar Diagram**

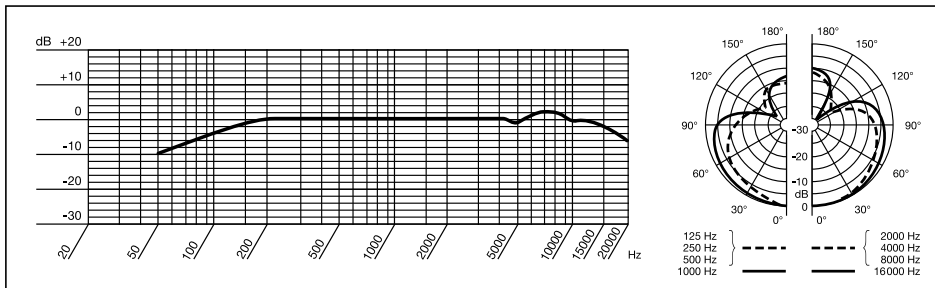

**CGN 99 H/S  
Frequency  
Response &  
Polar Diagram**

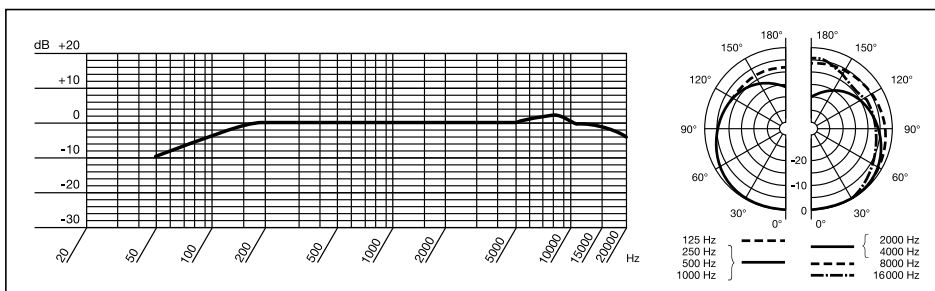

**CGN 99 C/L  
Frequency  
Response &  
Polar Diagram**

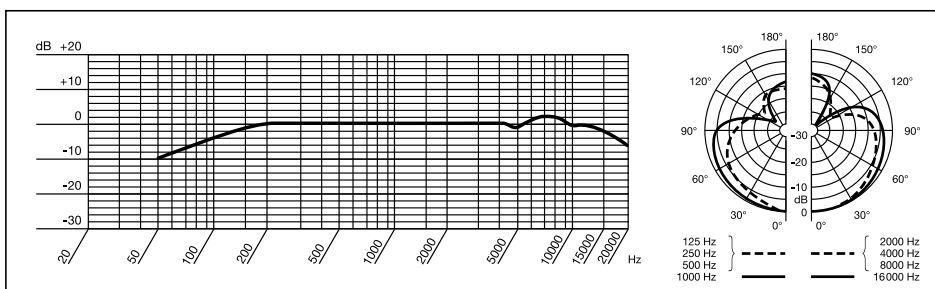

**CGN 99 H/L  
Frequency  
Response &  
Polar Diagram**

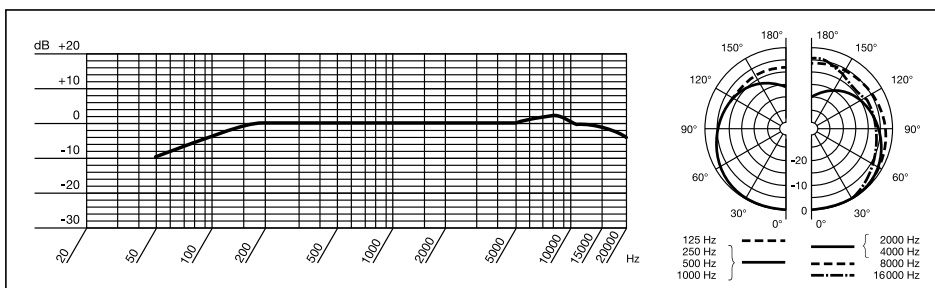

**CHM 99  
Frequency  
Response &  
Polar Diagram**

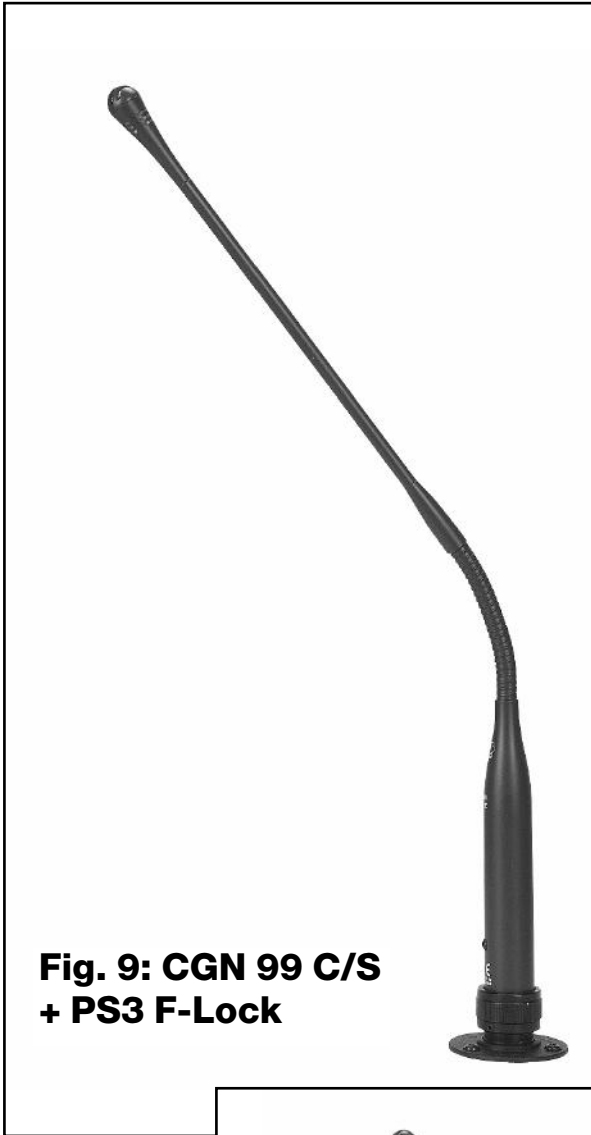

**Fig. 9: CGN 99 C/S  
+ PS3 F-Lock**

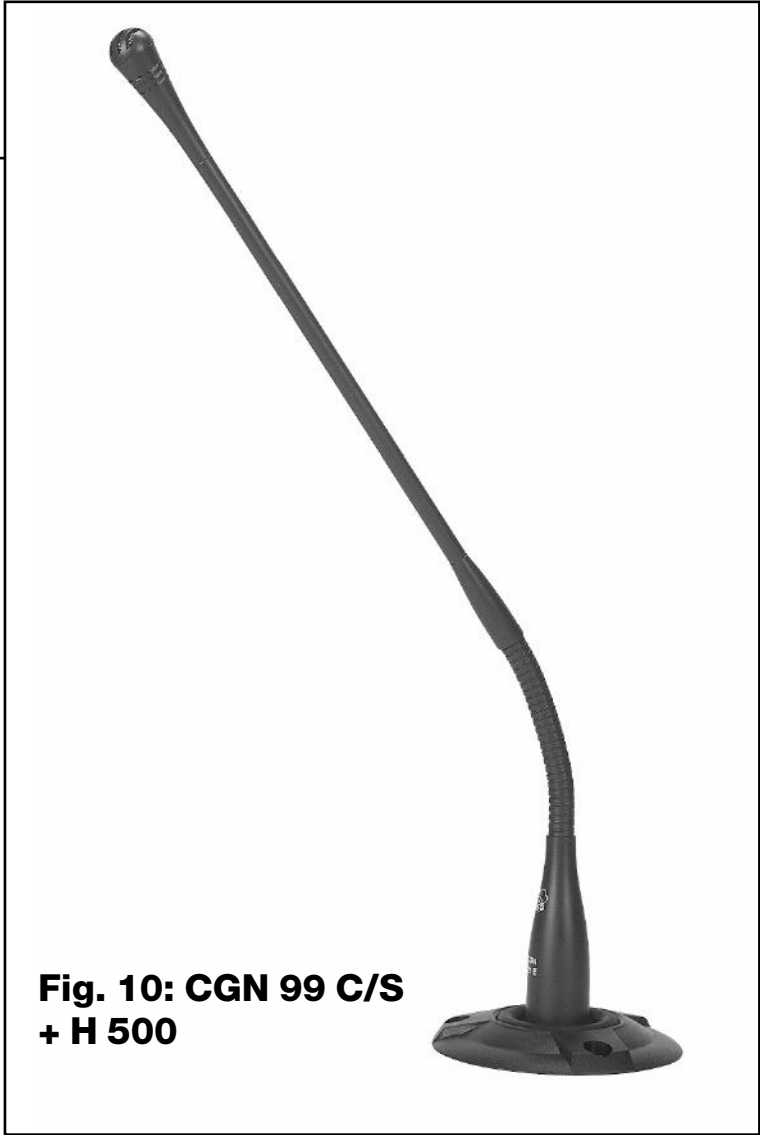

**Fig. 10: CGN 99 C/S  
+ H 500**



**Fig. 12: CGN 99 C/S  
+ SA 60 + ST 1**

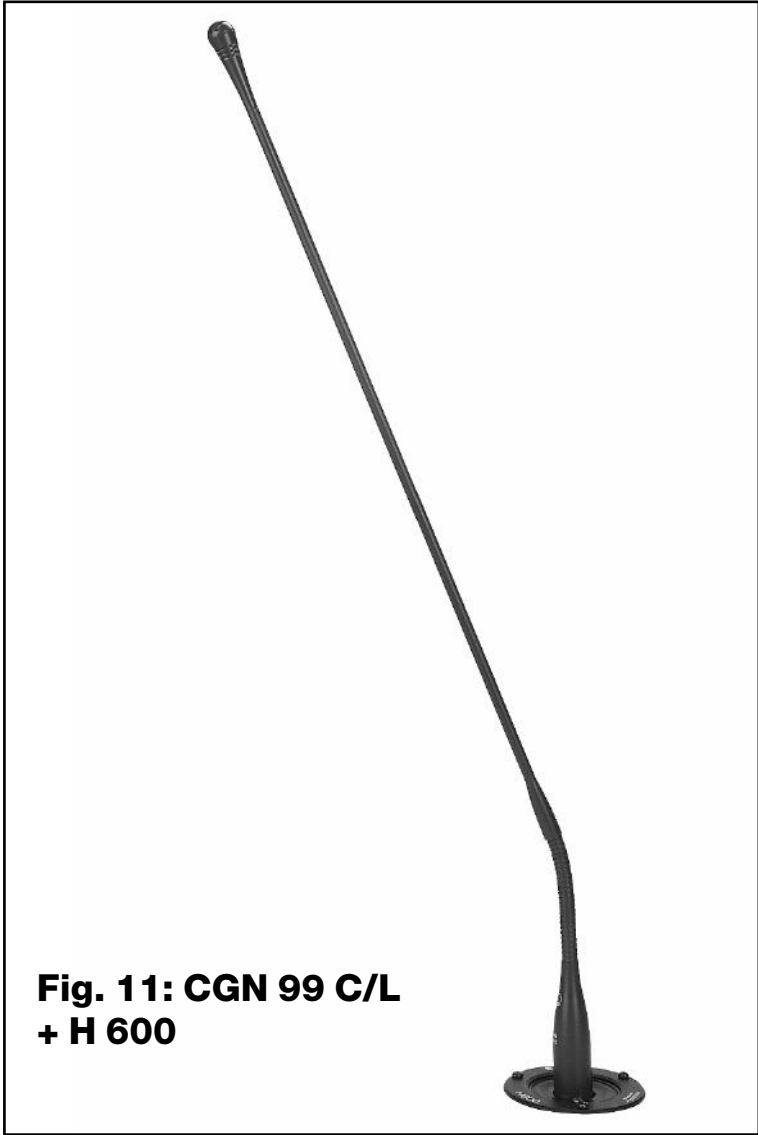

**Fig. 11: CGN 99 C/L  
+ H 600**



**Fig. 14: CHM 99**

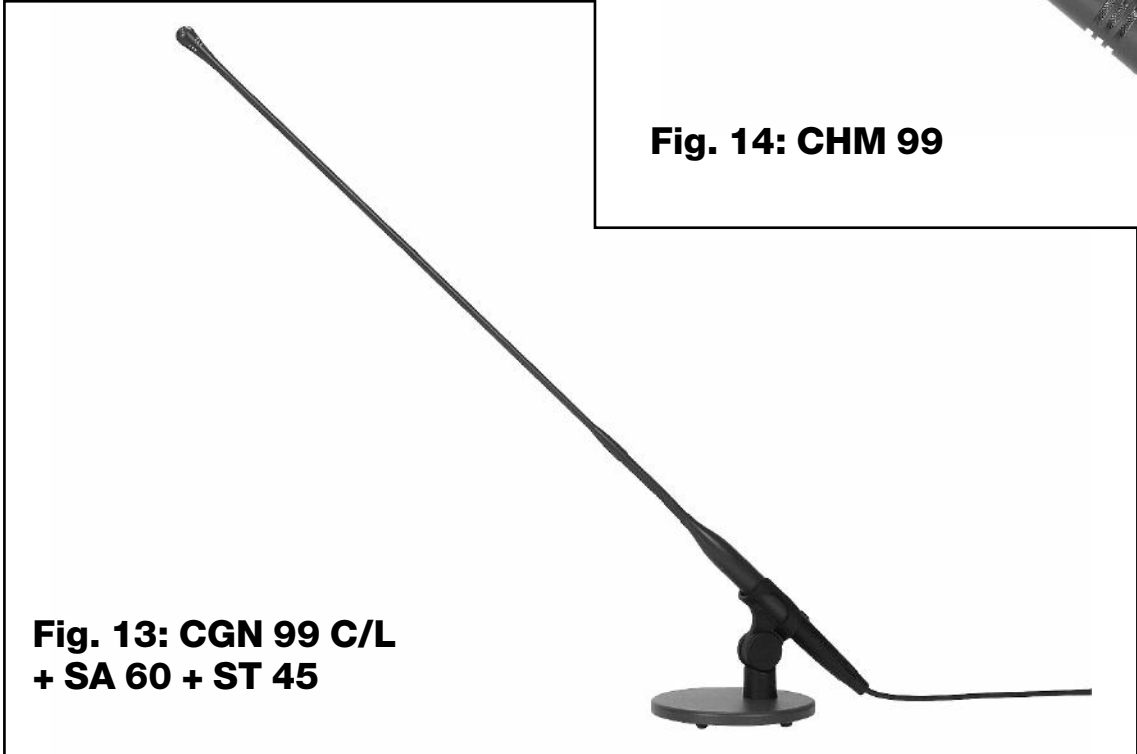

**Fig. 13: CGN 99 C/L  
+ SA 60 + ST 45**

Microphones · Headphones · Wireless Microphones · Wireless Headphones · Headsets · Electroacoustical Components

## AKG Acoustics GmbH

Lemböckgasse 21–25, 1230 Vienna/AUSTRIA, phone: (+43-1) 86654-0\*

e-mail: sales@akg.com

For other products and distributors worldwide visit [www.akg.com](http://www.akg.com)



ROHS OK

**H** A Harman International Company

Technische Änderungen vorbehalten. Specifications subject to change without notice. Ces caractéristiques sont susceptibles de modifications.  
Ci riserviamo il diritto di effettuare modifiche tecniche. Nos reservamos el derecho de introducir modificaciones técnicas. Especificações sujeitas a mudanças sem aviso prévio.

Printed in China.

9100 U 10630

