

# RoomMatch® Utility RMU108

## small-format under-balcony fill loudspeaker



### Key Features

**Award-winning RoomMatch sound** – now in smaller, 2-way, point-source designs for high-level foreground music, under-balcony, zone-fill and vocal-range floor monitor applications

**Bose EMB2 compression driver** – for lower distortion and improved vocal clarity compared to conventional foreground/fill models; also provides consistent mid/high sonic character compared to that of RoomMatch full-range and other RoomMatch Utility models

**90° x 60° constant-directivity high-frequency horn** – gives wide, even coverage and may be rotated in enclosure

**1 x Bose LF8 8-inch woofers** – with 2.0-inch long-excursion voice coil extends response to 80 Hz for lowest vocal range

**80 Hz – 16 kHz frequency response and 121 dB maximum peak SPL** – deliver the performance required for most demanding applications

**Flexible mounting with included U-bracket** – rear enclosure panel also includes 4 x M8 threaded inserts in 5.0" x 2.75" (127mm x 70mm) pattern to accept third-party accessory mounting brackets

### Product Overview

The RoomMatch Utility RMU108 small-format sound reinforcement loudspeaker is intended for use in high-quality foreground music, under-balcony, zone fill and vocal-range floor monitor applications. The design features a single Bose® EMB2 compression driver to provide mid/high frequency voicing similar to that of RoomMatch full-range array modules and all RoomMatch Utility models. A single 8-inch woofer provides full-range output and a multi-angle enclosure with rotatable high-frequency waveguide increases mounting flexibility.



TECHNICAL DATA SHEET

### Technical Specifications

System Performance		
Frequency Response (+/-3 dB) <sup>1</sup>	90 Hz - 16 kHz	
Frequency Range (-10 dB)	80 Hz - 16 kHz	
Recommended High-Pass Protection Filter	80 Hz with minimum 12-dB / octave filter	
Nominal Coverage Pattern (H x V)	90° x 60° (rotatable high-frequency horn)	
Crossover Type	passive (1.5 kHz crossover frequency)	
	<b>Bose extended-lifecycle test<sup>4</sup></b>	<b>AES transducer test<sup>6</sup></b>
Power Handling, long-term continuous	200 W	250 W
Power Handling, Peak	800 W	1000 W
Sensitivity (SPL / 1 W @ 1 m) <sup>2</sup>	91 dB	91 dB
Calculated Maximum SPL @ 1 m <sup>3</sup>	114 dB	115 dB
Calculated Maximum SPL @ 1 m, peak <sup>4</sup>	120 dB	121 dB
Transducers		
Low Frequency	1 x Bose LF8 high-excursion 8-inch woofers (2-inch voice coil)	
High Frequency	1 x Bose EMB2 extended-midband high-frequency compression driver (2-inch voice coil)	
Nominal Impedance	8 Ω	
Physical		
Finish	Two-part spray polyurethane coating, black or white	
Grille	18-gauge (1.2 mm) perforated steel, powder-coated finish, black or white	
Environmental	Indoor use only	
Connectors	Indoor use only	
Suspension / Mounting	2 x M8 threaded inserts (1 each side) for U-bracket; 4 x M8 threaded inserts on rear surface (127 x 70 mm, 4-bolt pattern), 2 x M8 threaded inserts on bottom for stand adapter	
Dimensions (Enclosure only)	9.3" H x 18.5" W x 10.5" D (236 mm H x 470 mm W x 267 mm D)	
Net Weight	21 lbs (9.5 kg) / 26 lbs (11.8 kg) with U-bracket	
Shipping Weight	29 lbs (13.2 kg)	
Product Code		
Black	638349-0110	
White	638349-0210	

#### Footnotes:

- 1 Frequency response and range measured on-axis with passive crossover in an anechoic environment.
- 2 Sensitivity measured in half-space boundary conditions with passive EQ, referenced to 1W/m.
- 3 Maximum SPL calculated from sensitivity and power handling specifications, exclusive of power compression.
- 4 Bose extended-lifecycle test using pink noise filtered to meet IEC268-5, 6-dB crest factor, 500-hour duration.

# RoomMatch® Utility RMU108

small-format under-balcony fill loudspeaker



5 AES standard 2-hour duration with IEC system noise.

TECHNICAL DATA SHEET

# RoomMatch® Utility RMU108

small-format under-balcony fill loudspeaker



## Directivity Index and Q

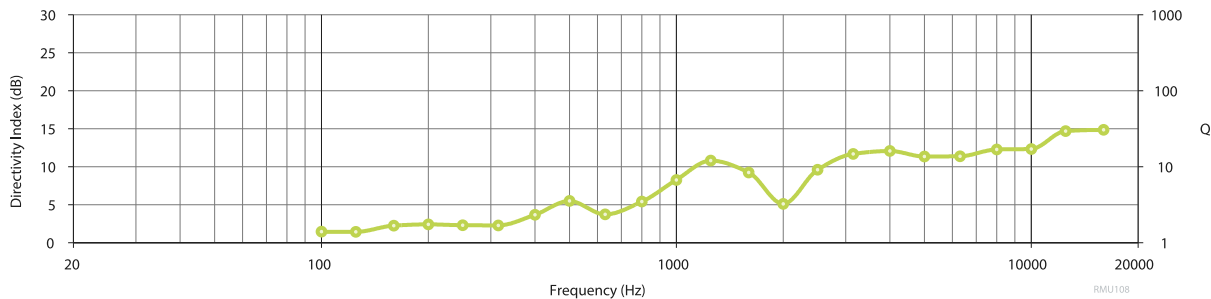

## Beamwidth

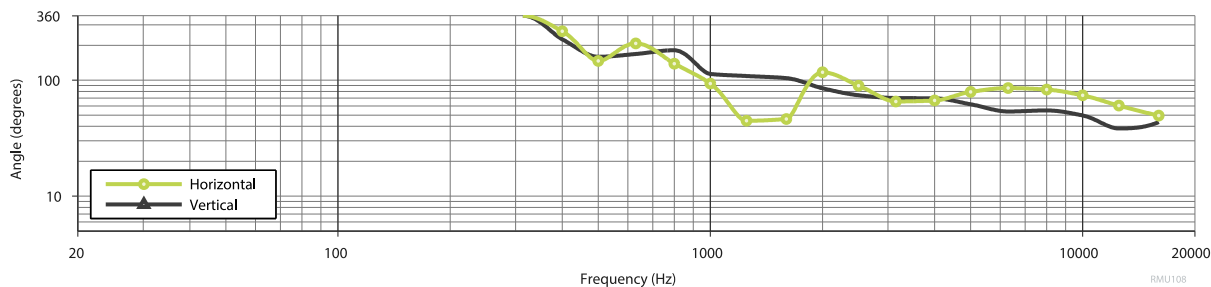

## Impedance

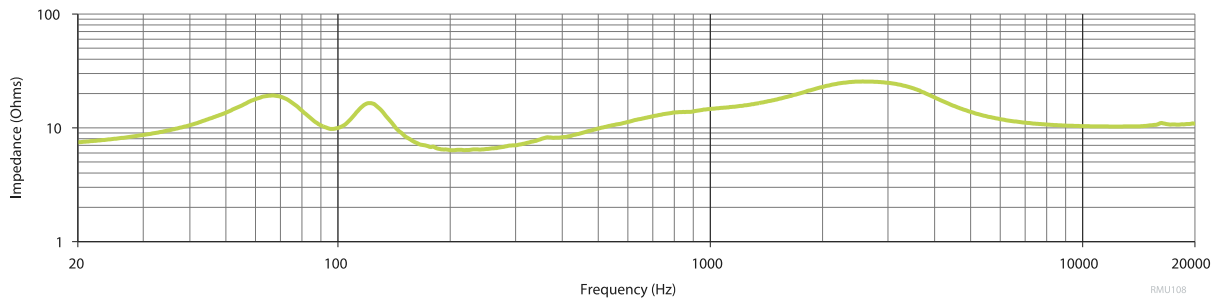

## On-Axis Response

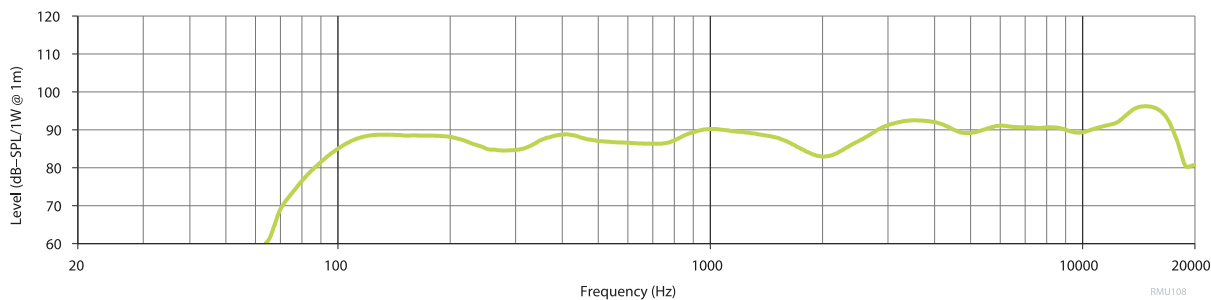

# RoomMatch® Utility RMU108

small-format under-balcony fill loudspeaker



## Wiring Diagram

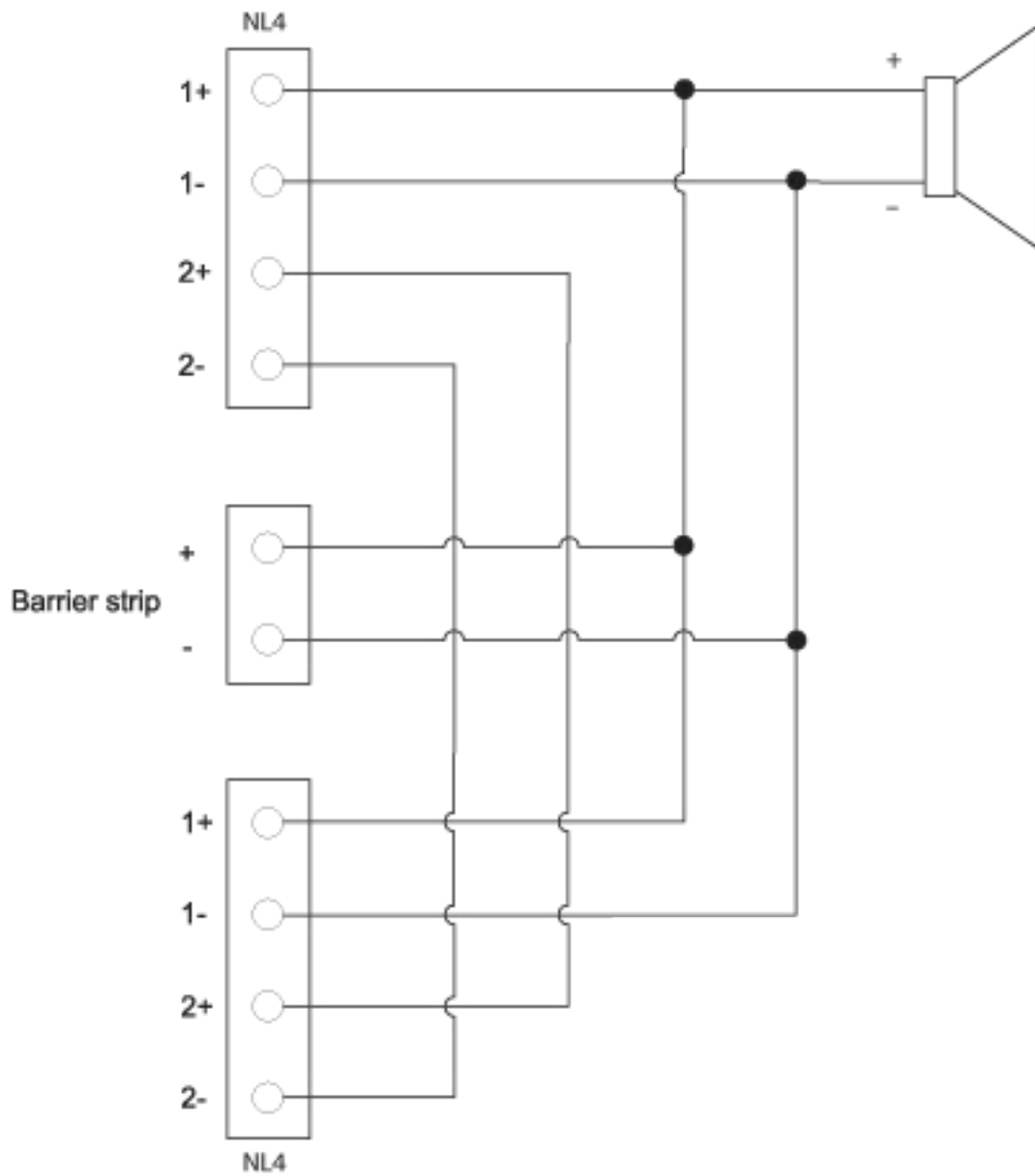

TECHNICAL DATA SHEET

# RoomMatch® Utility RMU108

small-format under-balcony fill loudspeaker



## Mechanical Diagrams

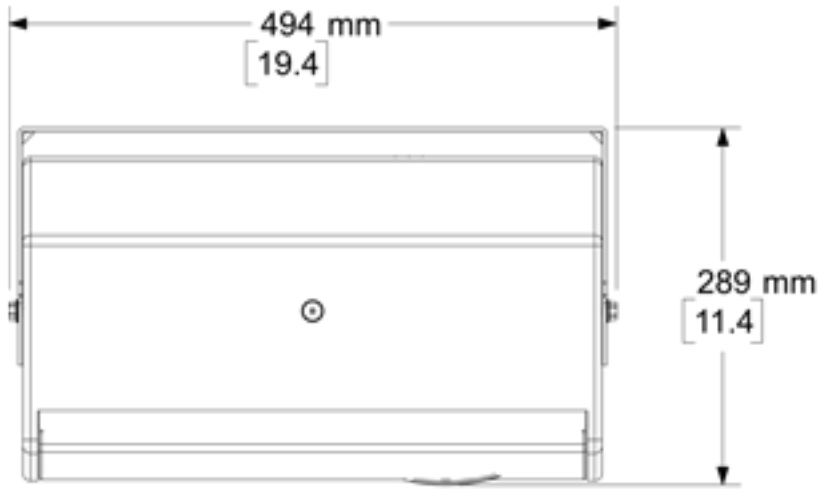

Top View



Front View

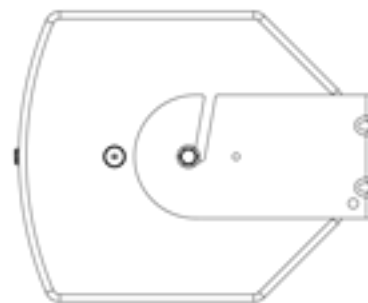

Right View

TECHNICAL DATA SHEET

# RoomMatch® Utility RMU108

small-format under-balcony fill loudspeaker



## Horizontal Plots

TECHNICAL DATA SHEET

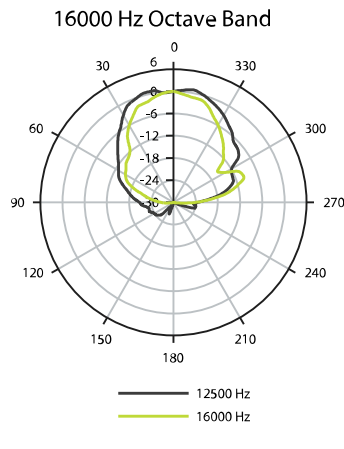
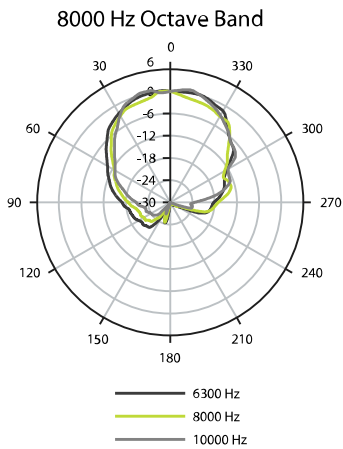
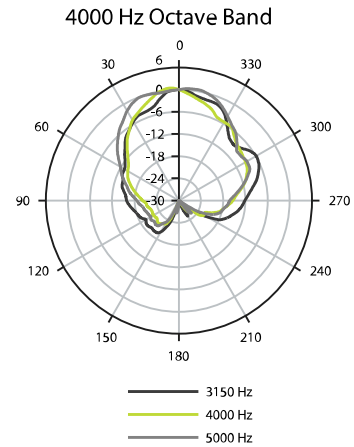
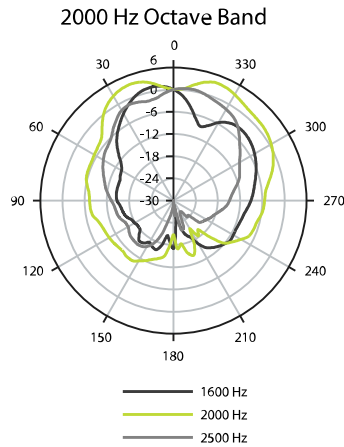
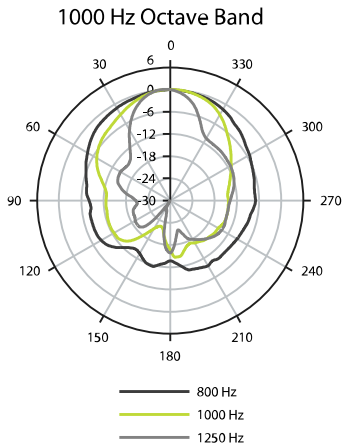
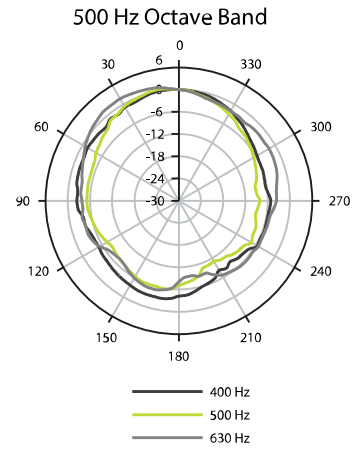
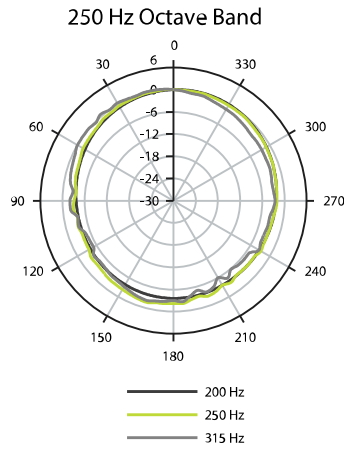
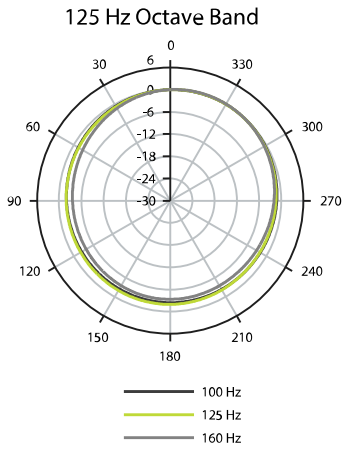

# RoomMatch® Utility RMU108

small-format under-balcony fill loudspeaker



## Vertical Plots

TECHNICAL DATA SHEET

125 Hz Octave Band

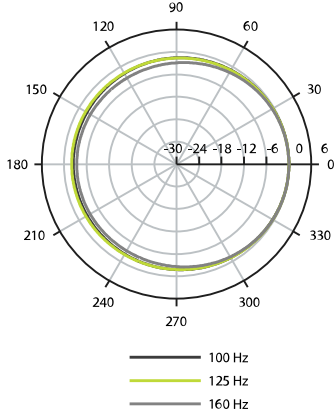

250 Hz Octave Band

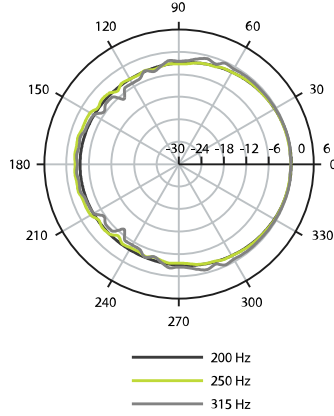

500 Hz Octave Band

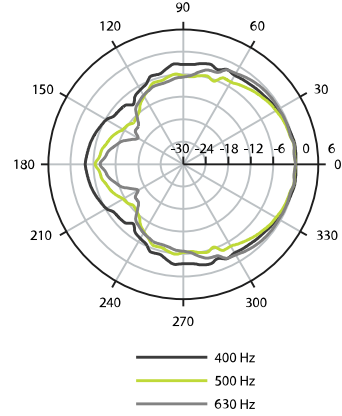

1000 Hz Octave Band

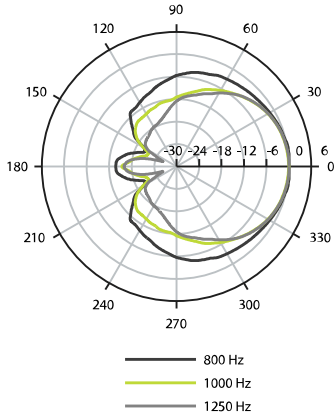

2000 Hz Octave Band

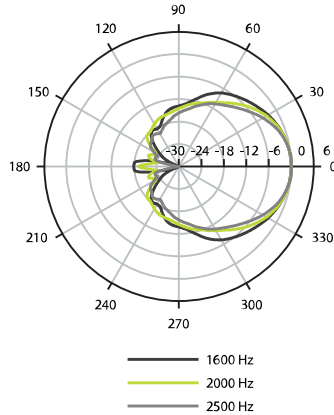

4000 Hz Octave Band

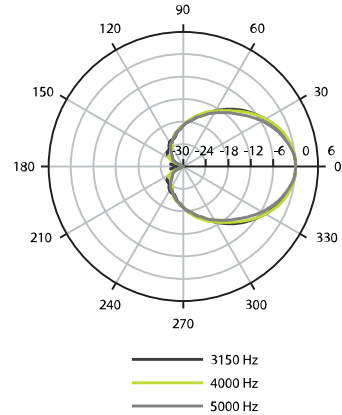

8000 Hz Octave Band

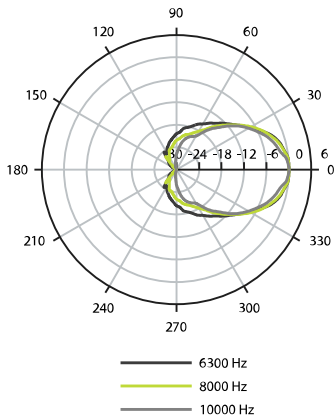

16000 Hz Octave Band

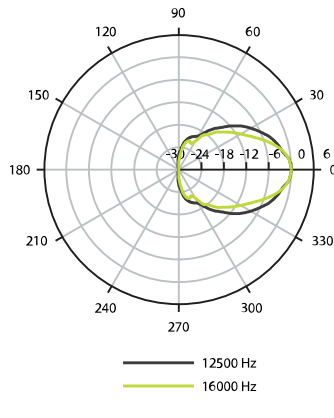

# RoomMatch® Utility RMU108

small-format under-balcony fill loudspeaker



## Architects' and Engineers' Specifications

The 2-way, full-range loudspeaker shall contain a single 2-inch titanium-diaphragm compression driver and a single 8-inch cone transducer with 2-inch voice coil. The loudspeaker shall contain a passive crossover network with 1500 Hz crossover point that provides consistent coverage and frequency response near crossover region.

The 2-way, full-range loudspeaker shall meet the following performance specifications: On-axis system frequency response shall be 90 Hz to 16 kHz (+/- 3 dB) without need for active equalization. The loudspeaker sensitivity shall be 91dB SPL in free field with 1 W input at 1 meter. The long-term power handling rating shall be 250 W (AES test methodology using pink noise, 6 dB crest factor, 2-hour duration). Maximum continuous output shall be 115 dB SPL and the maximum peak output shall be 121 dB SPL, both in free field. The nominal coverage pattern of the high-frequency horn shall be 90° horizontal and 60° vertical, with the horn capable of being rotated 90° in the enclosure by the installer.

The loudspeaker enclosure shall be constructed of Baltic birch plywood, protected by a two-part polyurethane coating. The multi-angle enclosure will allow placement on floors with an approximate 45° acoustic axis referenced to the floor surface. The transducers shall be protected by a 1.5-mm perforated steel grille with powder-coated finish. Input connectors shall be two (2) Neutrik® NL4 Speakon® connectors and one barrier strip terminal, wired in parallel. The finish will be available in black or white (paintable). Loudspeaker dimensions shall be 9.3" x 18.5" x 10.5" (236 x 470 x 267 mm) and net weight shall be 21 lb. (9.5 kg). The loudspeaker shall be the Bose RoomMatch Utility RMU108 model.